

### Transmitter TRANSMAG 2 with sensor 911/E

#### Overview



SITRANS F M 911/TRANSMAG 2

SITRANS F M TRANSMAG 2 is a pulsed alternating field magnetic flowmeter where the magnetic field strength is much higher than conventional DC pulsed magnetic flowmeters.

This makes it ideal for difficult applications like:

- High concentrated paper stock > 3%
- Heavy mining slurries
- Mining slurries with magnetic particles.

TRANSMAG 2 is used with the SITRANS F M 911/E sensor, available with diameters of DN 15 to DN 1000.

#### Benefits

- Fast signal processing with 16-bit technology
- Automatic recognition of sensor type and calibration data as result of SmartPLUG
- PROFIBUS PA (profile 2.0) / HART communication
- Simple menu operation with two-line display
- Self-monitoring functions
- Internal simulator (for all input and output functions)
- Monitoring of sensor using magnetizing current and reference voltage as well as wet electrode function
- Analog output and digital outputs for pulses, device status, limits, flow direction, frequency output
- Optional passive switch input for resetting the counter values or for switching off the measuring equipment (PZR)
- With pulsed alternating field for minimum conductivity of  $\geq 1 \mu\text{S}/\text{cm}$ , on request  $0.1 \mu\text{S}/\text{cm}$  depending on medium
- Fully-welded steel enclosure
- Liners available in hard rubber, PTFE, Linatex, Soft rubber or Novolak

#### Application

The main applications of the SITRANS F M transmitter TRANSMAG 2 can be found in the following sectors:

- Pulp and Paper industry
- Mining industry

The measuring procedure with pulsed alternating field patented by Siemens AG is particularly suitable for media with a high solids content, or magnetically conducting media.

#### Design

The complete flowmeter consists of a flow sensor and an associated transmitter from the SITRANS F M TRANSMAG 2 for pulsed alternating field. These are available as remote version. They operate according to Faradays law of induction where an electric voltage is induced in a conductor moving through a magnetic field.

#### Function

The TRANSMAG 2 is a microprocessor-based transmitter with a built-in alphanumeric display in several languages. The transmitters evaluate the signals from the associated electromagnetic sensors and also fulfil the task of a power supply unit which provides the magnet coils with a constant current.

The magnetic flux density in the sensor is additionally monitored by reference coils.

Further information on connection, mode of operation and installation can be found in the data sheets for the sensors.

#### Displays and keypad

Operation of the TRANSMAG 2 transmitter can be carried out using:

- Keypad and display unit
- HART communicator
- PC/laptop and SIMATIC PDM software via HART communication
- PC/laptop and SIMATIC PDM software using PROFIBUS PA communication

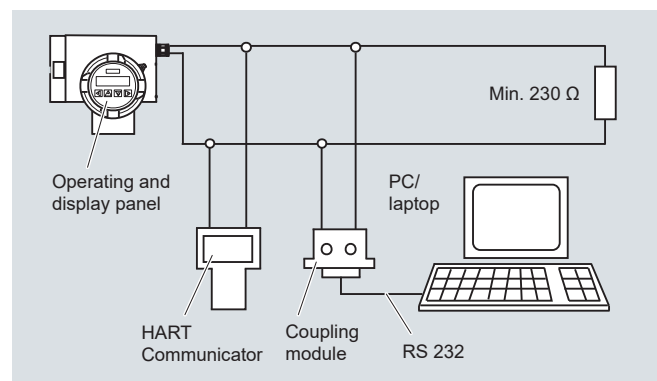

HART communication

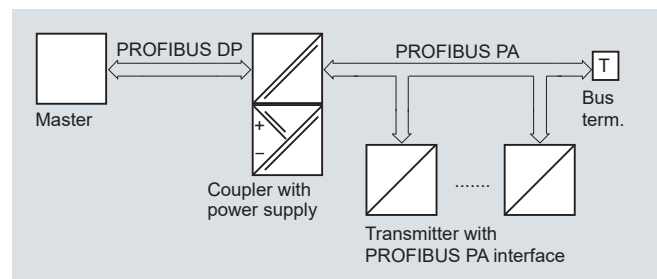

PROFIBUS PA communication

# Flow Measurement

## SITRANS F M

### Transmitter TRANSMAG 2 with sensor 911/E

#### Technical specifications

##### Mode of operation and design

Measuring principle	Electromagnetic with pulsed alternating field (PAC)
Magnetic field excitation	Automatic power supply synchronization
- 50 Hz AC power supply	Bipolar (16.7 Hz) Bipolar with prepulse (10 Hz) Unipolar (8.33 Hz)
- 60 Hz AC power supply	Bipolar (20 Hz) Bipolar with prepulse (12 Hz) Unipolar (10 Hz)

##### Accuracy under reference conditions

Measuring tolerance of pulse output	
• With $v > 0.25$ m/s (0.82 ft/s)	$\leq \pm 0.5\%$ of measured value $\pm 1.2$ m/s (3.9 ft/s)
• With $v < 0.25$ m/s (0.82 ft/s)	$\pm 2.5$ m/s (8.2 ft/s)
Measuring tolerance of analog output	As pulse output plus $\pm 0.1\%$ conversion error $\pm 20$ $\mu$ A
Repeatability	0.2% of measured value
<u>Reference conditions</u>	
• Process temperature	25 °C $\pm 5$ °C (77 °F $\pm 9$ °F)
• Ambient temperature	25 °C $\pm 5$ °C (77 °F $\pm 9$ °F)
• Warm-up time	Min. 30 min
• Installation conditions	Inlet pipe section $\geq 10 \times$ DN Outlet pipe section $\geq 5 \times$ DN Installed centered in pipe
• Medium	Water without gaseous or solid components

##### Outputs

Electrical isolation	Outputs electrically isolated from one another and from the power supply, max. 60 V permissible against PE/equipotential bonding
<u>Current output</u>	0/4 ... 20 mA Only for 20 mA / HART devices (7ME5034-0.... or 7ME5034-2....)
• Signal	
- Upper limit	0/4 ... 20 mA, selectable
- Failure	20 ... 22.5 mA, optional 3.6; 20 or 24 mA
• Load	
- Output	max. 600 $\Omega$ , max. load voltage 15 V DC
- For HART communication	$\geq 250$ $\Omega$
Communication	Via analog output with PC coupling module or HART communicator
• Protocol	HART, version 5.1
<u>Digital output</u>	
Signal	
• Output	Configurable as active or passive signals
- Active signal	24 V DC, $\leq 24$ mA, $R_i = 170$ $\Omega$
- Passive signal	Open collector, max. 30 V DC, 200 mA

##### Output configuration

• Pulse	
- Pulse significance	$\leq 5000$ pulses/s
- Pulse width	$\geq 0.1$ ms
• Limit frequency	$\leq 10000$ Hz
• Limits	Limits for flow and quantity, flow direction, alarm
<u>Digital output 2 (relay)</u> (only 7ME5034-0....)	
Relay	NC or NO function
• Rating	Max. 5 W, max. 50 V AC/DC, max. 200 mA
• Output configuration	Limits for flow and quantity, flow direction, alarm
<u>Digital input (optional to digital output 2)</u> (only 7ME5034-2....)	
• Input function configurable as high-active or low-active	Set measured value or counter to zero
• Signal voltage	Max. 30 V DC, $R_i = 3$ k: High level: +11 ... +30 V DC Low level: -30 ... +5 V DC

##### For PROFIBUS devices

PROFIBUS PA (for PROFIBUS-devices 7ME5034-1....)	
• Communication	Layer 1 and 2 according to PROFIBUS PA Transmission according to IEC 1158-2 Layer 7 (protocol layer) according to PROFIBUS PA and DP V1 (EN 50170) Device class B, device profile 2.0 Max. 4 simultaneous C2 connections
• Bus voltage	9 ... 32 V DC permissible
• Current consumption from bus	10 mA; limited to $\leq 15$ mA in event of fault by electrical current limitation

##### Rated operating conditions

Installation conditions	See also sensor
Ambient temperature	
• Operation	-20 ... +60 °C (-4 ... +140 °F)
• Display module	0 ... 50 °C (32 ... 122 °F)
Storage	-25 ... +80 °C (-13 ... +176 °F)
Degree of protection	IP67/NEMA 4X
Electromagnetic compatibility (EMC)	
• Emitted interference	To IEC/EN 61326 for use in industrial areas
• Noise immunity	To IEC/EN 61326 for use in industrial areas NAMUR NE21 for use in residential areas

# Flow Measurement

## SITRANS F M

### Transmitter TRANSMAG 2 with sensor 911/E

Medium conditions	
• Process temperature	-20 ... +150 °C (-4 ... 302 °F) depending on her liner
Minimum conductivity of medium	
• With SITRANS F M 911/E sensors	≥ 1 µS/cm, on request 0.1 µS/cm depending on medium
Design	
Weight of transmitter	4.4 kg (9.7 lb)
Remote version	Transmitter must be connected to sensor using shielded cable
Maximum cable length	100 m (328 ft)
Housing	Die-cast aluminium, painted
Displays and keypad	
General display	LCD, backlit, two lines with 16 characters each
Multi-display for	Flow, totalizer, flow velocity
Keypad	4 keys for entering parameters
Power supply	
corresponding to rating plate	
• AC supply	100 ... 250 V AC ± 15%, 47 ... 63 Hz
• Power consumption	Approx. 120 ... 630 VA, depen- ding on sensor
Power failure	Bridging of min. 1 power supply cycle (> 20 ms)
Line fuse	100 ... 230 V AC: T1.6A
Magnet current fuse	F5A / 250 V

#### Sensor cables between sensor and transmitter

The signal voltage proportional to the flow and present at the electrodes of the EMF is only a few µV to mV. Superimposed on this are electrochemical interferences resulting from the contact between the electrodes and liquid, and which can be up to several Volt. Also frequently superimposed are line frequency interferences, interferences resulting from vibrations on the pipelines or signal cables, as well as strong magnetic fields in the vicinity. Sufficient shielding must therefore be provided, as well as fixed routing of the signal cables (electrode and magnet current cable) in the case of remote versions. This also applies to devices with integral preamplifier (smartPLUG). The cable length between the sensor and transmitter must not exceed 100 m (328 ft).

Attention must also be paid to the cable routing. Signal cables must be routed free of vibration, and protected against strong magnetic and stray fields. In case of doubt, the sensor cables must be routed in earthed steel conduit.

Selection and Ordering data	Order No.
<b>SITRANS F M electromagnetic transmitter TRANSMAG 2</b> for alternating field, remote version, 110 ... 230 V AC	<b>7ME5034 - AA 1 - AA 0</b>
<b>Output/communication</b> 4 ... 20 mA with HART protocol PROFIBUS PA connection 4 ... 20 mA with HART protocol, digital input	0 1 2
<b>Operator display and keypad</b> Without With	0 1
<b>Cable glands</b> M20/M16 x 1.5 ½" NPT	1 2

This device is shipped with a Quick Start guide and the SITRANS F manual CD containing the complete manual library. Printed Operating Instructions are available for purchase via PMD

Selection and Ordering data	Order code
<b>Additional information</b>	
Please add "-Z" to Order No. and specify Order code(s) and plain text.	
Strengthened mounting bracket for wall and pipeline installation	<b>A02</b>
Measuring range, specify in plain text: Y01: 0 to ... m <sup>3</sup> /h	<b>Y01</b>
Pulse significance, specify in plain text: Y02: 0 to ... pulses/l	<b>Y02</b>
Setting of digital outputs, specify in plain text: Y03: Setting of digital outputs: ...	<b>Y03</b>
Measuring-point number (max. 8 characters), specify in plain text: Y15: .....	<b>Y15</b>
Measuring-point description (max. 16 characters), specify in plain text: Y16: .....	<b>Y16</b>
Stainless steel tag plate	<b>Y17</b>
Special design specify in plain text, state quotation	<b>Y99</b>

#### Operating instructions for SITRANS F M TRANSMAG 2

Description	Order No.
Operating instructions for SITRANS F M TRANSMAG 2	
• English	<b>A5E00102775</b>
• German	<b>A5E00192774</b>
• Spanish	<b>A5E00135276</b>
• French	<b>A5E00135275</b>

This device is shipped with a Quick Start guide and a CD containing further SITRANS F literature.







**All literature is also available for free at:**  
<http://www.siemens.com/flowdocumentation>





# Flow Measurement

## SITRANS F M

### Transmitter TRANSMAG 2 with sensor 911/E

#### Accessories

Description	Order No.	
Operating/Display module	<b>7ME5933-0AC00</b>	
Electronics cover with glass plate (non Ex)	<b>7ME5933-0AC01</b>	
Cover for sensor cable and gasket	<b>7ME5933-0AC02</b>	
Cover for mains supply/communication	<b>7ME5933-0AC03</b>	
Standard wall mounting bracket	<b>7ME5933-0AC04</b>	
Special wall-/pipe mounting bracket kit	<b>7ME5933-0AC05</b>	
Safety clamp for electronic cover with glass plate (7ME5933-0AC01)	<b>7ME5933-0AC06</b>	

Description	Order No.	
M20 cable gland set for power and output connection, grey PA plastic, 2 pcs. • cables Ø 6 ... 12 mm (0.24" ... 0.47") • -40 ... 100 °C (-40 ... 212 °F)	<b>A5E02246350</b>	
1/2" NPT cable gland set for power and output connection, grey PA plastic, 2 pcs. • cables Ø 6 ... 12 mm (0.24" ... 0.47") • -40 ... 100 °C (-40 ... 212 °F)	<b>A5E02246396</b>	
M16 x 1.5 cable gland set for sensor connection, brass chrome, 2 pcs. and 2 pcs. blind • cables Ø 5 ... 9 mm (0.20" ... 0.35") • -20 ... 105°C (-4 ... 221 °F)	<b>A5E02246369</b>	
IP68/NEMA 6P potting kit	<b>FDK-085U0220</b>	

# Flow Measurement SITRANS F M

## Transmitter TRANSMAG 2 with sensor 911/E

### Dimensional drawings

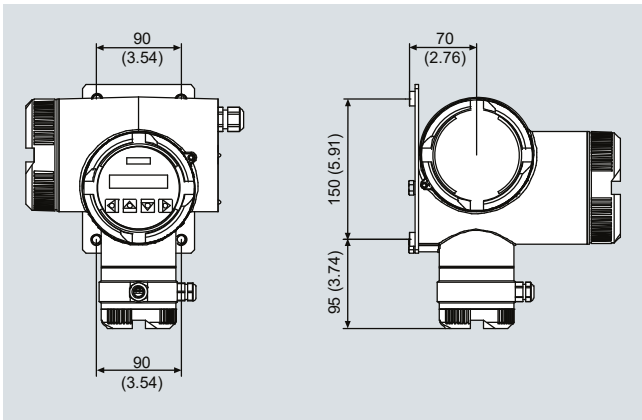

SITRANS F M transmitter TRANSMAG 2 with wall mounting bracket, dimensions in mm (inch)

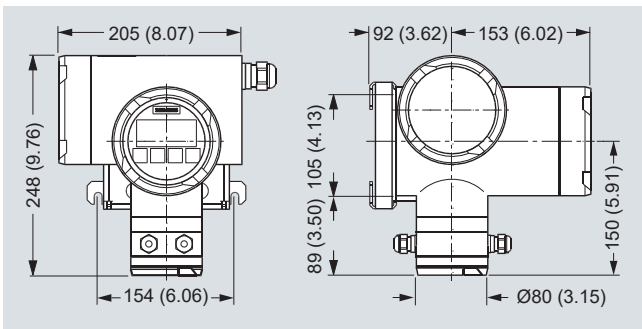

SITRANS F M transmitter TRANSMAG 2 with wall and pipeline mounting bracket, dimensions in mm (inch)

### Schematics

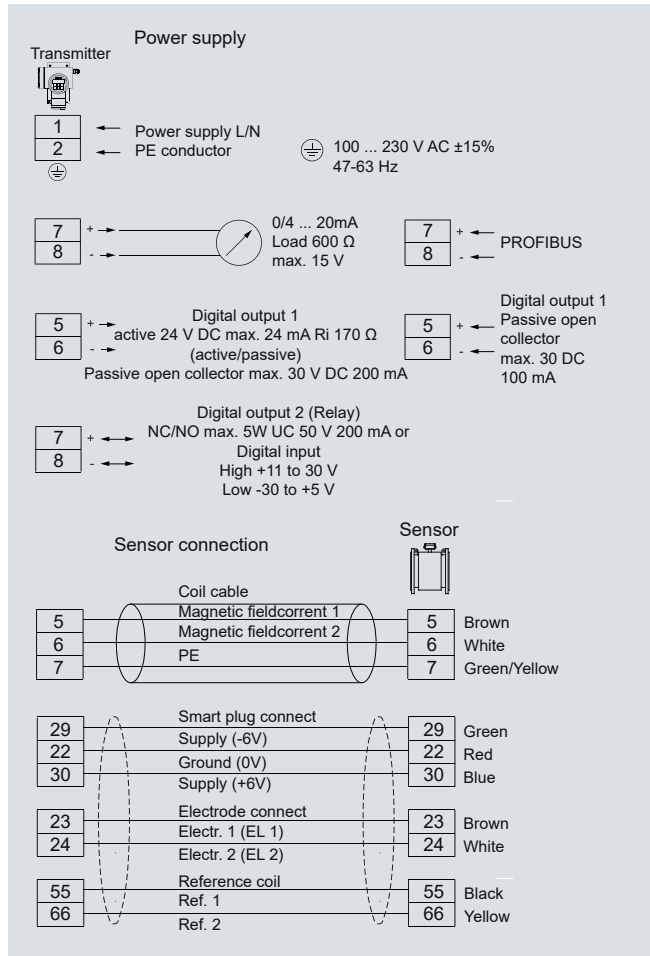

SITRANS F M transmitter TRANSMAG 2, connection diagram

# Flow Measurement

## SITRANS F M

### Transmitter TRANSMAG 2 with sensor 911/E

#### 911/E sensor

##### Process connection

Nominal diameters	DN 15 ... 1000 (½" ... 40")
Metering tube connections	EN 1092-1, ANSI B16.5, others on request

##### Rated operating conditions

<u>Installation conditions</u>	See system information
• Soft rubber liner	0 ... 70 °C (32 ... 158 °F)
• Hard rubber liner	0 ... 90 °C (32 ... 194 °F) Option: 100 °C (212 °F)
• PTFE liner	<ul style="list-style-type: none"> <li>• -20 ... +150 °C (-4 ... +300 °F) at 25 bar (363 psi)</li> <li>• -20 ... +100 °C (-4 ... +212 °F) at 40 bar (580 psi)</li> </ul>
• Linatex (rubber)	-40 ... +70 °C (-40 ... +158 °F) (for temperatures below -20 °C (-4 °F) AISI 316 flanges must be used)
• With Novolak liner	130 °C (266 °F) at 40 bar (580 psi)
Degree of protection	IP67/NEMA 4X Optional IP68/NEMA 6

##### Medium conditions

Minimum conductivity	> 1 µS/cm, on request 0.1 µS/cm depending on medium
Maximum flow velocity	12 m/s (39.4 ft/s)
Full scale value of flow velocity	0.15 ... 12 m/s (0.49 ... 39.4 ft/s)

#### Protection rings for liners



Function	To protect the edges of liners from abrasion (e.g. gravel, sand etc.). Used mainly with soft rubber liners and for PTFE liners at high temperatures from 100 to 150 °C (212 to 300 °F).
Contact with medium	Yes, please always check resistance to measured medium.
Material	Stainless steel mat. no. 1.4571/316Ti, optionally Hastelloy C276
Material thickness	The overall length of the sensor is increased by <ul style="list-style-type: none"> <li>• 6 mm for DN 15 to DN 150 (0.24" for ½" to 6") or</li> <li>• 10 mm for DN 200 to DN 600 (0.4" for 8" to 24")</li> </ul>
Standard	No, optional for PTFE and soft rubber liners. They are required for PTFE liners of PN 16 (MWP 232 psi) or more instead of protection washers, and must be ordered separately.
Order No.	<b>7ME5912-....</b>

#### Earthing washers



Function	Electrical reference and earthing of the medium. Required if the pipelines are not electrically conducting or are lined (plastic pipelines, concrete pipelines etc.). All earthing rings must be connected to the earthing screw present on the sensor.
Contact with medium	Yes, please always check resistance to measured medium.
Material	Stainless steel mat. no. 1.4571/316Ti, or Hastelloy C276
Material thickness	The overall length of the sensor is increased by 2 mm (0.08") per earthing ring.
Standard	No, only optional. Required between the medium and sensor for equipotential bonding between non-conducting pipelines or lined pipelines.
Order No.	<b>7ME5902-....</b>

#### Important:

The rings must be ordered together with the sensor. In case of replacement please include the sensor MLFB code on the order.

#### Notes on pressure equipment directive

The devices are designed for liquids of danger group "Gases of fluid group 1". The categories differ according to the version, and are listed in the table below.

The minimum temperature is defined at -10 °C (14 °F) for the flange materials C22.8 (1.0460) and ST52-5 (1.0570).

The minimum temperature is defined at -20 °C (-4 °F) for the flange material 1.4571/316Ti.

#### Classification according to pressure equipment directive (PED 97/23/EC)

Nominal diameter		Nominal pressure		Permissible media	Category
DN	(inches)	PN	(MWP psi)		
15 ... 25	(½" ... 1")	10 ... 40	(145 ... 580)	Gases fluid group 1 and liquids fluid group 1	Article 3.3
32 ... 100	(1¼" ... 4")	10	(145)	Gases fluid group 1 and liquids fluid group 1	I
32 ... 50	(1¼" ... 2")	16	(232)	Gases fluid group 1 and liquids fluid group 1	I
32 ... 40	(1¼" ... 1½")	25	(363)	Gases fluid group 1 and liquids fluid group 1	I
100 ... 350	(4" ... 12")	10	(145)	Gases fluid group 1 and liquids fluid group 1	II
65 ... 200	(2½" ... 8")	16	(232)	Gases fluid group 1 and liquids fluid group 1	II
50 ... 125	(2" ... 5")	25	(363)	Gases fluid group 1 and liquids fluid group 1	II
32 ... 80	(1¼" ... 3")	40	(580)	Gases fluid group 1 and liquids fluid group 1	II
350 ... 600	(14" ... 24")	10	(145)	Gases fluid group 1 and liquids fluid group 1	III
250 ... 600	(10" ... 24")	16	(232)	Gases fluid group 1 and liquids fluid group 1	III
150 ... 600	(6" ... 24")	25	(363)	Gases fluid group 1 and liquids fluid group 1	III
100 ... 600	(4" ... 24")	40	(580)	Gases fluid group 1 and liquids fluid group 1	III

# Flow Measurement

## SITRANS F M

### Transmitter TRANSMAG 2 with sensor 911/E

Selection and Ordering data	Order No.
<b>Flowsensor SITRANS F M 911/E remote version</b>	<b>7ME5610 -</b> ■ ■ ■ ■ ■ - ■ A A ■
<b>Nominal diameter</b>	
DN 15 (1/2")	1 V
DN 25 (1")	2 D
DN 40 (1 1/2")	2 R
DN 50 (2")	2 Y
DN 65 (2 1/2")	3 F
DN 80 (3")	3 M
DN 100 (4")	3 T
DN 125 (5")	4 B
DN 150 (6")	4 H
DN 200 (8")	4 P
DN 250 (10")	4 V
DN 300 (12")	5 D
DN 350 (14")	5 K
DN 400 (16")	5 R
DN 450 (18")	5 Y
DN 500 (20")	6 F
DN 600 (24")	6 P
DN 700 (28")	6 Y
DN 750 (30")	7 D
DN 800 (32")	7 H
DN 900 (36")	7 M
DN 1000 (40")	7 R
<b>Flange norm and pressure rating</b>	
EN 1092-1, PN 10 (DN 200 ... 1000 (8" ... 40"))	B
EN 1092-1, PN 16 (DN 65 ... 1000 (2 1/2" ... 40"))	C
EN 1092-1, PN 25 (DN 200 ... 600 (8" ... 24"))	E
EN 1092-1, PN 40 (DN 15 ... 600 (1/2" ... 24"))	F
ANSI B16.5, Class 150 (1/2" ... 24"), max 19.6 bar (285 psi) at 20 °C (68 °F)	J
ANSI B16.5, Class 300 (1/2" ... 24"), max 51.1 bar (741 psi) at 20 °C (68 °F)	K
AWWA C207 Class D (28" ... 40")	L
JIS 10 K (1/2" ... 24")	R
<b>Flange material</b>	
Mid steel flanges 1.0460/1.0570	1
Stainless steel flanges, AISI 316 Ti / 1.4571	3
<b>Liner material</b>	
Soft rubber	1
PTFE (without protection washers)	3
Hardrubber	4
Linatex	5
Novolak (sealing material FFKM)	6
<b>Electrode material</b>	
AISI 316 Ti (mat. no. 1.4571/316 Ti)	1
Hastelloy C276	2
Platinum head with shaft (mat. no. 1.4571/316Ti)	3
Titanium	4
Tantalum	5
<b>Cable glands/terminal box</b>	
Metric: Polyamide terminal box	1
1/2" NPT: Polyamide terminal box	2

This device is shipped with a Quick Start guide and the SITRANS F manual CD containing the complete manual library. Printed Operating Instructions are available for purchase via PMD

Selection and Ordering data	Order Code
<b>Additional information</b>	
Please add "-Z" to Order No. and specify Order code(s) and plain text.	
Two earthing (grounding) electrodes made of mat. no. 1.4571/316Ti	<b>A02</b>
Two earthing (grounding) electrodes made of Hastelloy C4/2.4610	<b>A04</b>
Two earthing (grounding) electrodes made of Platinum head	<b>A05</b>
Two earthing (grounding) electrodes made of Titanium	<b>A06</b>
Two earthing (grounding) electrodes made of Tantalum	<b>A07</b>
Factory certificate to EN 10204-2.2	<b>C14</b>
Acceptance test B to DIN 50049, section 3.1 and EN 10204	<b>C16</b>
Silicone-free materials	<b>Y04</b>
Tag name plate, stainless steel, add plain text	<b>Y17</b>
Other postproduction requirements, add plain text	<b>Y99</b>

Selection and Ordering data	Order No.	Order code
<b>SITRANS F M TRANSMAG 2 and sensor 911/E</b>	<b>7ME5930 -</b>	
<b>Cable for remote versions</b>	<b>5 ■ A 0 0 - 0 A A 0 ■ ■ ■</b>	
Cable kit for sensor 911/E with alternating field, Magnet current cable 3 x 1.0 mm <sup>2</sup> (3 x 0.0016 inch <sup>2</sup> ), electrode/reference cable 7 x 0.5 mm <sup>2</sup> (7 x 0.0008 inch <sup>2</sup> ) with shield PVC		
• Length: 5 m (16.4 ft)	B	
• Length: 10 m (32.8 ft)	C	
• Length: 20 m (65.6 ft)	D	
• Length: 30 m (98.4 ft)	E	
• Specify other length: in plain text	Z	<b>J 1 Y</b>



# Flow Measurement

## SITRANS F M

### Transmitter TRANSMAG 2 with sensor 911/E

Selection and Ordering data	Order No.	Order code	Selection and Ordering data	Order No.	Order code
<b>SITRANS F M</b> electromagnetic flowmeter			<b>SITRANS F M</b> electromagnetic flowmeter		
<b>Protection rings for flow sensor 911E</b> (per pair)	7ME5912-		<b>Earthing rings for flow sensor 911E</b> (per unit)	7ME5902-	
<b>Liner</b>			<b>Liner</b>		
Hard rubber/soft rubber		1	Hard rubber/soft rubber		1
Novolak		7	Novolak		7
PTFE		0	PTFE		0
<b>Nominal diameter</b>			<b>Nominal diameter</b>		
<i>for PTFE, mat. no. 1.4571/316 Ti</i>			<i>Mat. no. 1.4571/316 Ti</i>		
DN 15 (1/2")		AA	DN 15 (1/2")		AA
DN 20 (3/4")		BA	DN 20 (3/4")		BA
DN 25 (1")		CA	DN 25 (1")		CA
DN 32 (1 1/4")		DA	DN 32 (1 1/4")		DA
DN 40 (1 1/2")		EA	DN 40 (1 1/2")		EA
DN 50 (2")		FA	DN 50 (2")		FA
DN 65 (2 1/2")		GA	DN 65 (2 1/2")		GA
DN 80 (3")		HA	DN 80 (3")		HA
DN 100 (4")		JA	DN 100 (4")		JA
DN 125 (5")		KA	DN 125 (5")		KA
DN 150 (6")		LA	DN 150 (6")		LA
DN 200 (8")		MA	DN 200 (8")		MA
DN 250 (10")		NA	DN 250 (10")		NA
DN 300 (12")		PA	DN 300 (12")		PA
Other nominal diameters: specify in plain text		ZA	DN 350 (14")		QA
<i>for Hard/Soft rubber, Novolak, mat. no. 1.471/316 Ti</i>			DN 400 (16")		RA
DN 15 (1/2")		AB	DN 500 (20")		SA
DN 20 (3/4")		BB	DN 600 (24")		TA
DN 25 (1")		CB	DN 700 (28")		UA
DN 32 (1 1/4")		DB	DN 800 (32")		VA
DN 40 (1 1/2")		EB	DN 900 (36")		WA
DN 50 (2")		FB	DN 1000 (40")		XA
DN 65 (2 1/2")		GB	Other nominal diam.: specify in plain text		ZA
DN 80 (3")		HB	<i>Material Hastelloy C4/2.4610</i>		J 1 Y
DN 100 (4")		JB	DN 15 (1/2")		AB
DN 125 (5")		KB	DN 20 (3/4")		BB
DN 150 (6")		LB	DN 25 (1")		CB
DN 200 (8")		MB	DN 32 (1 1/4")		DB
DN 250 (10")		NB	DN 40 (1 1/2")		EB
DN 300 (12")		PB	DN 50 (2")		FB
Other nominal diameters: specify in plain text		ZB	DN 65 (2 1/2")		GB
<b>Flange design</b>			DN 80 (3")		HB
Flange to DIN		1	DN 100 (4")		JB
Flange to ANSI		2	DN 125 (5")		KB
Flange to JIS		3	DN 150 (6")		LB
			DN 200 (8")		MB
			DN 250 (10")		NB
			DN 300 (12")		PB
			DN 350 (14")		QB
			DN 400 (16")		RB
			DN 500 (20")		SB
			DN 600 (24")		TB
			Other nominal diam.: specify in plain text		ZB
			<b>Flange design</b>		J 1 Y
			Flange to DIN		1
			Flange to ANSI		2
			Flange to JIS		3

# Flow Measurement

## SITRANS F M

### Transmitter TRANSMAG 2 with sensor 911/E

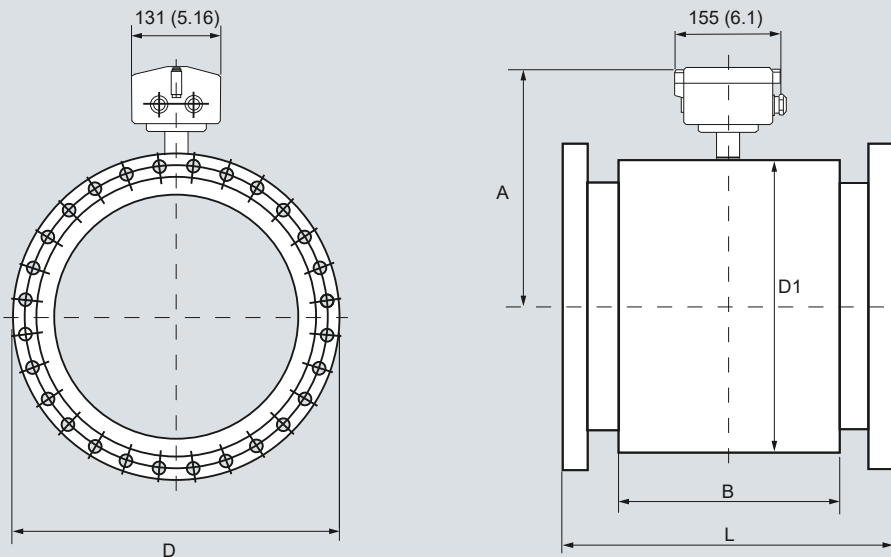

SITRANS F M flow sensor 911/E, remote version, dimensions in mm (inches)

#### Build-in length 911/E [in mm and inches]

Nominal diameter	DN 15	DN 25	DN 40	DN 50	DN 65	DN 80	DN 100	DN 125	DN 150	DN 200	DN 250
	½"	1"	1 ½"	2"	2 ½"	3"	4"	5"	6"	8"	10"
<b>Build-in length L<sup>1)</sup></b>											
Hard rubber version	270			330	340		370		410	470	
Linatex/soft rubber version	(10.63)			(12.99)	(13.39)		(14.57)		(16.14)	(18.50)	
PTFE-liner without protection rings	270			330	340		370		410	470	
	(10.63)			(12.99)	(13.39)		(14.57)		(16.14)	(18.50)	
Novolak-version	-			275	325	335	333	362		401	460
				(10.83)	(12.79)	(13.19)	(13.11)	(14.25)		(15.79)	(18.11)
<b>Dimensions of sensor housing</b>											
Housing width B	170 (6.69)									240 (9.45)	
Height A	206 (8.11)		222 (8.74)	229 (9.02)	262 (10.32)		274 (10.79)	286 (11.26)	299 (11.78)	334 (13.15)	258 (14.10)
Housing diameter D <sub>1</sub>	135 (5.35)		167 (6.58)	182 (7.17)	247 (9.73)		272 (10.71)	296 (11.65)	322 (12.68)	392 (15.43)	440 (17.32)
Weight of PN16 version in kg (MWP 232 psi version in lb) approx.	8.0 (17.64)	8.5 (18.74)	11.5 (25.35)	25.0 (55.12)	26 (57.32)	27 (59.53)	28 (61.73)	34 (74.95)	38 (83.78)	68 (149.9)	81 (178.6)
<b>Build-in length L<sup>1)</sup></b>											
Hard rubber version	500	550	600	650	650	780	910		1040	1170	1300
Linatex/soft rubber version	(19.68)	(21.65)	(23.62)	(25.59)	(25.59)	(30.71)	(35.83)		(40.95)	(46.06)	(51.18)
PTFE-liner without protection rings	500	550	600	660	650	780	-				
	(19.68)	(21.65)	(23.62)	(25.98)	(25.59)	(30.71)					
Novolak-version	489	538	592	638	638	772	903		1033	1163	1293
	(19.25)	(21.18)	(23.31)	(25.12)	(25.12)	(30.39)	(35.55)		(40.63)	(45.79)	(50.91)
<b>Dimensions of sensor housing</b>											
Housing width B	240 (9.45)	225 (8.86)	250 (9.84)	270 (10.63)	300 (11.81)	360 (14.17)	420 (16.54)		500 (19.69)	560 (22.05)	620 (24.41)
Height A	383 (15.08)	375 (14.76)	400 (15.75)	433 (17.05)	453 (17.84)	505 (19.88)	558 (21.97)	590 (23.23)	608 (23.94)	658 (25.91)	713 (28.07)
Housing diameter D <sub>1</sub>	490 (19.29)	474 (18.66)	524 (20.63)	591 (23.26)	629 (24.76)	734 (28.90)	839 (33.03)	904 (35.59)	939 (36.97)	1039 (40.91)	1150 (45.28)
Weight of PN10 Version in kg (MWP 145 psi version in lb) approx.	95 (209.4)	118 (260.2)	161 (354.9)	185 (407.9)	233 (513.7)	401 (884.1)	420 (925.9)	450 (992.1)	500 (1102.3)	560 (1234.6)	620 (1366.9)

<sup>1)</sup> Tolerance for build-in length: L + 0.0 mm (0.00 inches) /- 4.0 mm (-0.157 inches).  
With protection rings or washers for > DN25 + 6.0 mm, > DN200 + 10.0 mm (> 1" + 0.236 inches. > 8" + 0.394 inches)