



thermoMETER CTlaser

Innovative precision infrared temperature sensor marking the actual spot size on your measurement target at any distance

- Measuring range from -50°C to 975°C
- Extreme small measurement spot down to 0.9mm
- Real mapping of the actual spot size, with automatic laser protection
- Precision optics (75:1) with different models for a specific focus point
- Up to 85°C ambient temperature without cooling
- Fully programmable instrument for enhanced signal processing and I/O control
- Separate controller with easy accessible programming keys and multi colour LCD backlit display

Optical specifications thermoMETER CTlaser

□ = smallest spot size (mm)

Standard optics																
SF75 optics 75:1	20	19.5	19	18.5	18	17.5	17	16.5	16	20.5	25	34	43	52		
distance in mm	0	150	300	450	600	750	900	1050	1200	1350	1500	1800	2100	2400		
Close Focus optics																
CF1 optics 75:1	20	9	5	0.9	10	25	40	55	70	85	100	115	130	160	190	220
CF2 optics 75:1	20	16	14	11	8	1.9	9	16.5	24	31	38	45.5	53	68	82	97
CF3 optics 75:1	20	17	16	14	11	7	2.75	8.5	14	19.5	25.5	31	37	48	60	71
CF4 optics 75:1	20	19	18.5	18	17	15.5	14	12.5	11	9	7.5	5.9	9	15	20	26
distance in mm	0	40	50	70	100	150	200	250	300	350	400	450	500	600	700	800

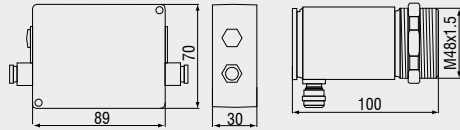

Product identification

CTL - SF75 - C3

Cable length [3 m Standard / 8 m / 15 m]
 Focus [SF75 / CF1 / CF2 / CF3 / CF4]
 thermoMETER CTLaser

Model		CTL-SF75-C3
Optical resolution		75:1
Temperature range ¹		-50°C to 975°C
Spectral range		8 to 14 μm
System accuracy ^{2,3}		±1% or ±1°C
Repeatability ²		±0.5% or ±0.5°C
Temperature resolution		0.1°C
Response time (90% signal)		120ms
Emissivity/gain ¹		0.100 to 1.100
Transmissivity/gain ¹		0.100 to 1.000
Signal processing ¹		peak hold, valley hold, average; extended hold function with threshold and hysteresis
Certificate of calibration		optional
Outputs/analogue	channel 1 channel 2 optional	0/4 to 20mA, 0 to 5/10 V, thermocouple J, K sensor temperature (-40 to 85°C as 0 to 5V or 0 to 10V), alarm output relay: 2 x 60VDC/ 42VAC _{eff} ; 0.4A; optically isolated
Alarm output		open - collector (24V/ 50mA)
Outputs/digital	optional	USB, RS232, RS485, CAN, Profibus DP, Ethernet
Output impedances	current output voltage output	mA max. 500Ω (with 5 to 36VDC) mV min. 100kΩ load impedance; thermocouple 20Ω
Inputs		programmable functional inputs for external emissivity adjustment, ambient temperature compensation, trigger (reset of hold functions)
Cable length		3m (standard), 8m, 15m
Power supply		8 to 36VDC; max. 160mA
Laser		class II (635nm), 1mW, ON/OFF via controller or software
Environmental rating		IP 65 (NEMA-4)
Ambient temperature		sensor: -20°C to 85°C (50°C if Laser ON) controller: 0°C to 85°C
Storage temperature		sensor: -40°C to 85°C controller: -40°C to 85°C
Relative humidity		10 to 95%, non condensing
Vibration	sensor	IEC 68-2-6: 3 G, 11 to 200Hz, any axis
Shock	sensor	IEC 68-2-27: 50 G, 11ms, any axis
Weight		sensor: 600g; controller: 420g

¹ adjustable via controller or software

² ± ambient temperature: 23 ±5°C; whichever is greater

³ temperature of the object >0°C

Accessories page 28 - 29

- ▶ Mounting bracket
- ▶ Air purge collar
- ▶ Rail mount adapter for controller
- ▶ Water cooled housing
- ▶ Interface kit
- ▶ Software CompactConnect
- ▶ Certificate of calibration



LASER RADIATION
 DO NOT STARE IN THE BEAM
 CLASS 2 LASER
 EN60825-1:2002
 P≤1mW; λ=630-650nm

Controller

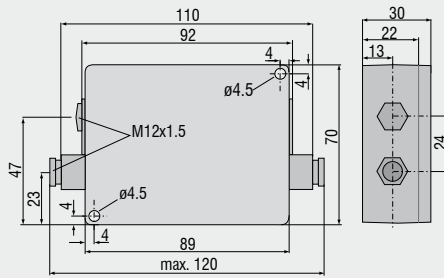

CTLaser / CTLaserFAST / CTLaserGLASS / CTLaserM1/M2 / CTLaserM3 / CTLaserCOMBUSTION

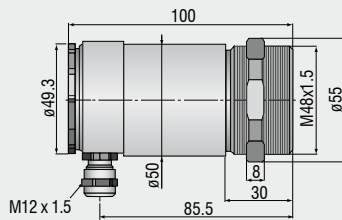

CTratioM1

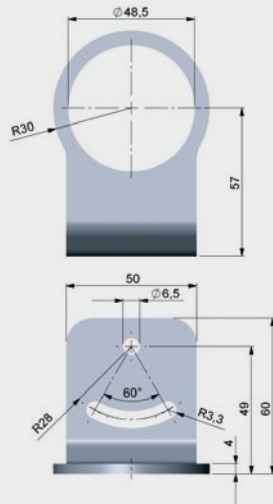
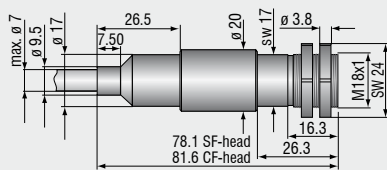

TM-FB-CTL Mounting bracket (fixed);
included with CTL sensors

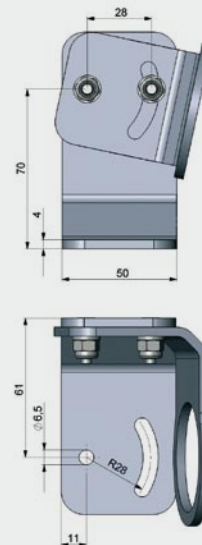

TM-AB-CTL Mounting bracket (adjustable)



TM-W-CTL Water cooled housing and air purge collar TM-AP-CTL, mounted on adjustable mounting bracket TM-AB-CTL

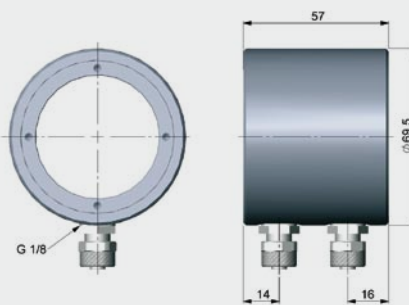

TM-W-CTL Water cooled housing

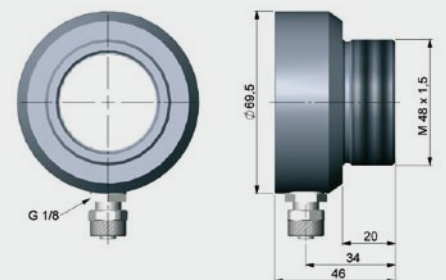

TM-AP-CTL Air purge collar

Mechanical accessories

Art. No.	Model	
2970238	TM-AB-CTL	Mounting bracket, adjustable, stainless steel
2970239	TM-AP-CTL	Air purge collar, stainless steel
2970240	TM-W-CTL	Water cooled housing, stainless steel, for ambient temperatures up to 175°C
2970241	TM-RAIL-CTL	Rail mount adapter for CTlaser controller
2970242	TM-COV-CTL	Closed cover for controller
2970243	TM-MN-CTL	Mounting nut, stainless steel (spare)
2970244	TM-FB-CTL	Mounting bracket, fixed, stainless steel (spare)
2970298	TM-A20UN-CTL	Screw adapter M48x1 on 20UN-2A screw including mounting nut



TM-J-CTL Cooling jacket (length 228mm, ø89mm) with adjustable mounting bracket TM-JAB-CTL; up to 315°C ambient temperature

High temperature accessories

2970366	TM-J-CTL	Cooling jacket (length 228mm, ø89mm) (connection kit TM-CONK-CTL is required)
2970374	TM-CONK-CTL	Connection kit: sensor with axial cable exit, for integration in cooling jacket
2970368	TM-JAB-CTL	Adjustable mounting bracket for cooling jacket
2970369	TM-MF-CTL	Mounting flange M48x1.5 for mounting a CTL sensor
2970370	TM-AST300-CTL	Sighting tube M48x1.5, 300 mm length
2970371	TM-PA-CTL	Pipe adapter M48x1.5
2970372	TM-RM-CTL	Furnace wall mount accessory for CTlaser (TM-MF-CTL, TM-AST300-CTL and TM-PA-CTL)



TM-MF-CTL Mounting flange M48x1.5 for mounting a CTL sensor

Calibration

2970253	TM-CERT-CTL	Certificate of calibration
2970324	TM-HTCERT-CTL	Certificate of calibration for CTlaser M1-/M2-/M3-/G-

Interfaces

2970245	TM-USBK-CTL	USB interface kit incl. computer cable, software CompactConnect
2970246	TM-RS232K-CTL	RS232 interface kit incl. computer cable, software CompactConnect
2970338	TM-RS485USBK-CTL	RS485-USB-adapter, incl. PC cable, RS485 board, software CTconnect, terminal block, for use with TM-485B-CTL
2970248	TM-RS485B-CTL	RS485 interface board
2970249	TM-CANK-CTL	CAN-Bus interface for optris CT/ protocol: CANopen Presettings: module address 20 (14H), 250kBaud, 0-60°C
2970250	TM-PFBDPK-CTL	Profibus-DPV1 interface for CT selectable with DIN M12 or SUB-D connection
2970251	TM-ETHNK-CTL	Ethernet-Kit: interface board, external Ethernet adapter, software CompactConnect
2970252	TM-RI-CTL	Relay interface: Two optically isolated relays, 60VDC/ 42VACRMS, 0.4A



TM-RM-CTL Furnace wall mount accessory for CTlaser / CTratio: TM-MF-CTL, TM-AST300-CTL und TM-PA-CTL

Sensor cables and high temperature cables

2970374	TM-CONK-CTL	Connector-Kit for cables with connector
4800254.003	TM-CB3C-CTL	Sensor cable with adapter (3m)
4800254.003H	TM-CB3HC-CTL	High-temperature sensor cable with adapter (3m)
4800254.008	TM-CB8C-CTL	Sensor cable with adapter (8m)
4800254.008H	TM-CB8HC-CTL	High-temperature sensor cable with adapter (8m)
4800254.015	TM-CB15C-CTL	Sensor cable with adapter (15m)
4800254.015H	TM-CB15HC-CTL	High-temperature sensor cable with adapter (15m)

CTratio

Art. No.	Model	
2970348	TM-FB-CTR	Mounting bracket, adjustable in one axis
2970349	TM-AB-CTR	Mounting bracket, adjustable in two axes
2970395	TM-AP-CTR	Air purge collar
2970373	TM-RM-CTR	Furnace wall mount accessory for CTratio