



thermoMETER CTP-3

Exact temperature measurement of thin plastic film made from PE, PP, PS

- Robust and applicable without cooling in ambient temperatures up to 75°C
- Elimination of transmissivity using a polymer-specific absorption band
- Separate controller with easy accessible programming keys and backlit display
- Selectable analogue outputs 0/4-20mA, 0-5V, 0-10V, thermocouple type K or J
- Optional USB, RS485, RS232 interface, relay outputs (2x electrically isolated), CAN, Profibus DP, Ethernet

Optical specifications thermoMETER CTP-3

□ = smallest spot size (mm)

Standard Focus										
SF15	15:1	7	8	13	20	27	33	40	47	53
	distance (mm)	0	100	200	300	400	500	600	700	800

Model		CTP-3SF15-C3
Optical resolution		15:1
Temperature range ¹		50 to 400°C
Spectral range		3.43µm
System accuracy ²		±1% or ±3°C
Repeatability ²		±1.5°C
Temperature resolution		0.1°C
Response time		100ms
Emissivity/gain ¹		0.100 to 1.100
Transmissivity ¹		0.100 to 1.100
Signal processing ¹		peak hold, valley hold, average; extended hold function with threshold and hysteresis
Outputs/analogue	channel 1	0/4 to 20mA, 0 to 5/10V, thermocouple J, K
	channel 2	sensor temperature (0 to 75°C as 0 to 5V or 0 to 10V), alarm
	optional	relay: 2 x 60VDC/42VAC _{eff} ; 0.4A; electrically isolated
Outputs/digital	optional	USB, RS232, RS485, CAN, Profibus DP, Ethernet
Output impedances	current output	mA max. 500Ω (8 to 36VDC)
	voltage output	mV min. 100kΩ load impedance thermocouple 20Ω
Inputs		programmable functional inputs for external emissivity adjustment, ambient temperature compensation, trigger (reset of hold functions)
Cable length		3m (standard), 8m, 15m
Power supply		8 to 36VDC; max. 100mA
Protection class		IP65 (NEMA-4)
Ambient temperature		sensor: 0°C to 75°C controller: 0°C to 75°C
Storage temperature		sensor: -40°C to 85°C controller: -40°C to 85°C
Relative humidity		10 to 95%, non condensing
Vibration	sensor	IEC 68-2-6: 3 G, 11 to 200Hz, any axis
Shock	sensor	IEC 68-2-27: 50 G, 11ms, any axis
Weight		sensor with massive housing: 200g; controller: 420g

¹ adjustable via programming keys or software

² at ambient temperature: 23 ±5°C; whichever is greater

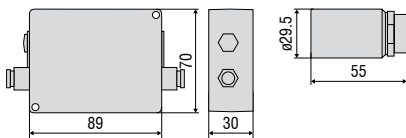

Product identification

CTP-	3	SF15-	C3
Cable length [3m (standard) / 8m]			
Focus [SF15]			
Spectral range [3.43µm]			
thermoMETER CTP			

CT / CTfast / CTM1/M2/M3

controller

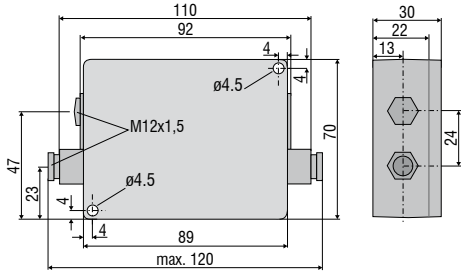

ancillary CF lens (optional)



sensor

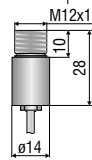

CThot / CTP-3 / CTP-7

controller

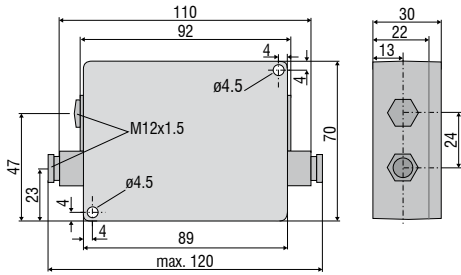

sensor with protective housing

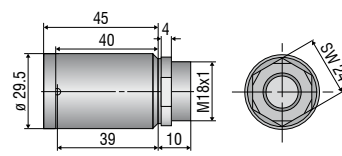

CTM3-XL

controller

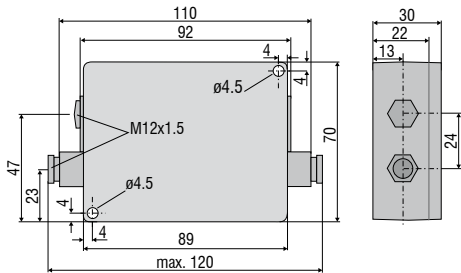

sensor

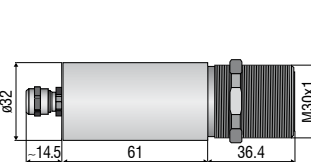

CTex

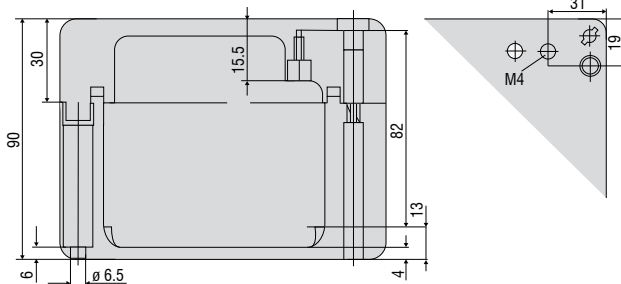
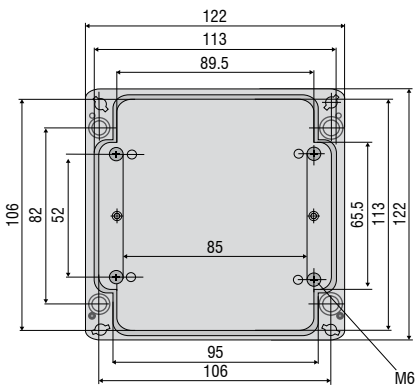

Mechanical accessories		
Art. No.	Model	
2970203	TM-FB-CT	Mounting bracket, fixed
2970325	TM-FB2-CT	Mounting bracket, adjustable in one axis, for simultaneous assembly of CT sensor and laser sighting aid
2970336	TM-FBMH-CT	Mounting bracket, adjustable in one axis, for massive housing
2970204	TM-AB-CT	Mounting bracket, adjustable in 2 axes
2970205	TM-MB-CT	Mounting bolts with M12x1 thread
2970206	TM-MG-CT	Mounting fork, adjustable in 2 axes, with M12x1 fastening
2970207	TM-AP-CT	Air purge collar for sensors from 10:1 lens
2970335	TM-APS-CT	Air purge collar for sensors from 10:1 lens made from stainless steel
2970208	TM-AP2-CT	Air purge collar for sensor with 2:1 lens
2970209	TM-APL-CT	Air purge collar, laminar
2970210	TM-APLCF-CT	Air purge collar, laminar with integrated ancillary CF lens
2970357	TM-APLCFH-CT	Air purge collar, laminar with integrated ancillary CF lens for M1/M2/M3/M5 sensors
2970386	TM-APMH-CT	Air purge collar made from stainless steel for massive housing
2970211	TM-RAM-CT	Right angle mirror for measurements 90° to the sensor axis
2970212	TM-RAIL-CT	Rail mount adapter for CT controller
2970213	TM-COV-CT	Closed cover for controller
2970214	TM-MHS-CT	Massive housing made from stainless steel
2970215	TM-MHSCF-CT	Massive housing made from stainless steel with integrated ancillary CF lens
2970358	TM-MHSCFH-CT	Massive housing made from stainless steel with integrated ancillary CF lens for M1/M2/M3/M5 sensors
2970216	TM-MHA-CT	Massive housing made from anodised aluminium
2970217	TM-MHACF-CT	Massive housing made from anodised aluminium with integrated ancillary CF lens
2970359	TM-MHACFH-CT	Massive housing made from anodised aluminium with integrated ancillary CF lens for M1/M2/M3/M5 sensors
2970218	TM-MHB-CT	Massive housing made from brass
2970219	TM-MHBCF-CT	Massive housing made from brass with integrated ancillary CF lens
2970360	TM-MHBCFH-CT	Massive housing made from brass with integrated ancillary CF lens for M1/M2/M3/M5 sensors
2970220	TM-PT-CT	Protective tube made from brass
2970326	TM-PA-CT	Pipe adapter for the mounting of reflection protection tubes
2970327	TM-ST20-CT	Reflection protection tube; length 20mm
2970328	TM-ST40-CT	Reflection protection tube; length 40mm
2970329	TM-ST88-CT	Reflection protection tube; length 88mm
2970221	TM-LST-CT	Laser sighting aid for CT sensors incl. batteries (2xAlkaline AA)
2970300	TM-LSTOEM-CT	OEM laser sighting aid, 635nm, 3.5m cable, for connection to CT controller
2970300-008	TM-LSTOEM-CT(008)	OEM laser sighting aid, 635nm, 8m cable, for connection to CT controller
2970222	TM-EX-CT	Accessories kit for using CT in Ex areas (Zone 1: PTB 01 ATEX 2053/ E II (1/2) G [EEx ia/ib] IIC/IIIB), pre-assembled EX box, without Zener barriers, applicable in combination with CT sensors (except for CTfast)

Optical accessories		
Art. No.	Model	
2970201	TM-CF-CT	Ancillary CF lens (only for SF models)
2970202	TM-PW-CT	Protective window (only for SF models)
2970297	TM-CFAG-CT	Ancillary lens with external thread
2970330	TM-CFH-CT	Ancillary lens for M1/M2/M3/M5 sensors
2970331	TM-CFHAG-CT	Ancillary lens with external thread for M1/M2/M3/M5 sensors
2970299	TM-PWAG-CT	Protective window with external thread
2970332	TM-PWH-CT	Protective window for M1/M2/M3/M5 sensors
2970333	TM-PWHAG-CT	Protective window with external thread for M1/M2/M3/M5 sensors

Interfaces		
Art. No.	Model	
2970223	TM-USBK-CT	USB interface kit: USB interface, USB cable, Software CompactConnect, second cable gland for controller
2970224	TM-RS232K-CT	RS232 interface: RS232 interface, computer cable, software CompactConnect, second cable gland for controller
2970338	TM-RS485USBK-CTL	RS485-USB-adapter, incl. PC cable, software CompactConnect and CTmulti, second cable gland for use with interface board TM-RS485B-CT
2970226	TM-RS485B-CT	RS485 interface board incl. second cable gland
2970227	TM-CANK-CT	CAN-Bus interface for thermoMETER CT/ protocol: CANopen presettings: module address 20 (14H), 250kbaud, 0-60°C
2970228	TM-PFBDPK-CT	Profibus-DPV1 interface for thermoMETER CT with plug-in connection
2970229	TM-ETHNK-CT	Ethernet-Kit: interface board, external Ethernet adapter, software CompactConnect
2970230	TM-RI-CT	Relay interface: Two electrically isolated relays, 60VDC/ 42VAC _{RMS} , 0.4A

Calibration		
Art. No.	Model	
2970231	TM-CERT-CT	Certificate of calibration
2970310	TM-HTCERT-CT	Certificate of calibration for CTM sensors

CTM3-XL		
Art. No.	Model	
2970352	TM-FBXL-CT	Mounting bracket, adjustable in one axis
2970353	TM-ABXL-CT	Mounting bracket, adjustable in 2 axes
2970354	TM-APXL-CT	Air purge collar, stainless steel
2970361	TM-XLCERT-CT	Certificate of calibration



TM-FB-CT Mounting bracket, adjustable in one axis

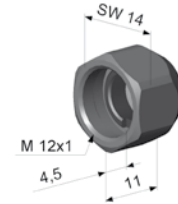
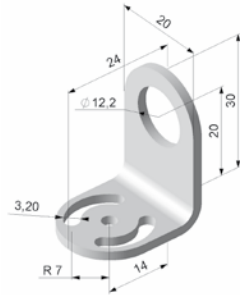

TM-CF-CT Ancillary CF lens (only for SF models)

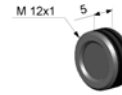

TM-CFAG-CT Ancillary CF lens with external thread
TM-PWAG-CT Protective window with external thread



TM-AB-CT Mounting bracket, adjustable in two axes

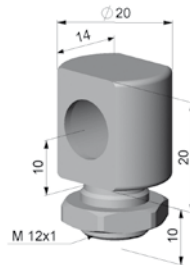

TM-MB-CT Mounting bolt with M12x1 thread
adjustable in one axis



TM-APL-CT Air purge collar, laminar and
TM-MG-CT Mounting fork



TM-MG-CT Mounting fork with M12x1 thread, adjustable in two axes

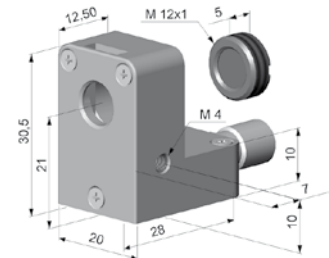

TM-APLCF-CT
Ancillary CF lens/protective window - integrable variant
for laminar air purge collar

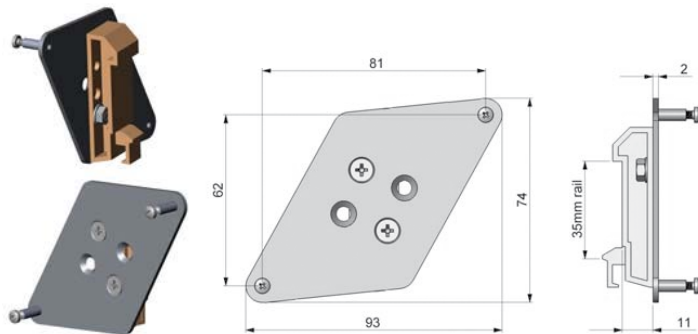

TM-RAIL-CT Rail mount adapter for controller

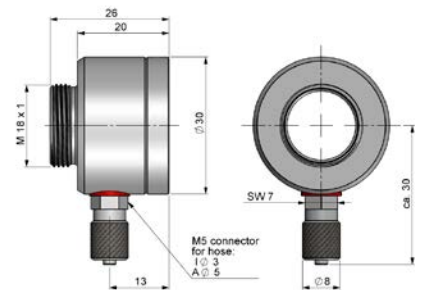

TM-APMH-CT Air purge collar made from stainless steel
for massive housing



TM-PA-CT Pipe adapter for reflection protection tube

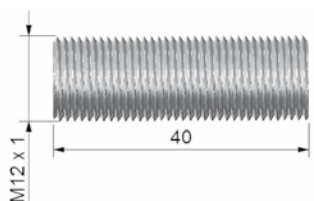

TM-ST40-CT Reflection protection tube



TM-LST-CT Laser sighting aid, battery-operated (2x Alkaline AA), for alignment of CT sensors (dimensions identical to CT sensor)

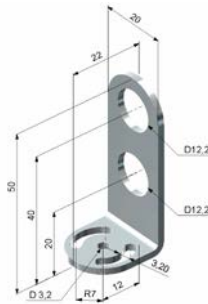

TM-FB2-CT Mounting bracket for sensor and laser sighting aid



TM-RAM-CT Right angle mirror



TM-MHS-CT Massive housing, stainless steel
 TM-MHA-CT Massive housing, aluminium
 TM-MHB-CT Massive housing, brass

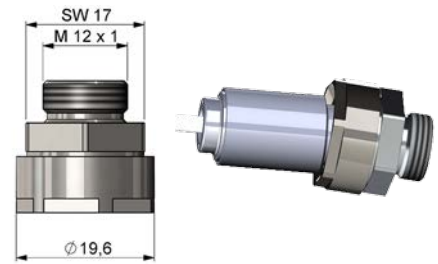
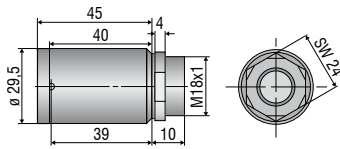

TM-TAS-CT Pivoted joint for CT sensors



Dirt and deposit on the lens like smoke, steam and high air humidity (condensation) are avoided or reduced by using an air purge collar.

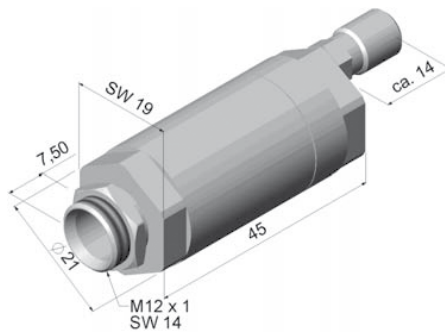

TM-AP-CT Standard air purge collar for 10:1 / 15:1 / 22:1 lenses

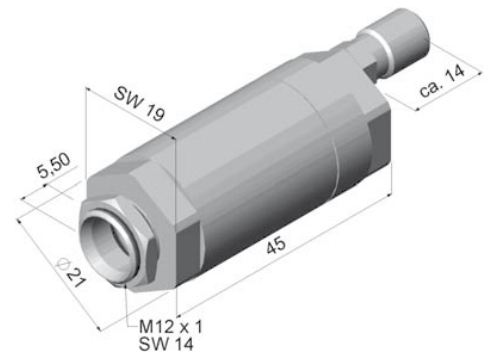

TM-AP2-CT Standard air purge collar for 2:1 lens

Further IR temperature measurement devices from Micro-Epsilon



thermoIMAGER TIM
Compact USB thermal imaging cameras
for precise thermography



thermoMETER CTVideo/CSVideo
IR temperature sensors with
crosshair laser sighting and video output



thermoMETER Handheld
Innovative handheld pyrometer with laser
sighting for inspection and maintenance