



thermoMETER CTM3

This state of the art non contact infrared temperature sensor operates with a wavelength of $2.3\mu\text{m}$. This special spectral range minimises the emissivity errors and allows readings through glass down to low temperatures of 50°C . The integrated photon detector guarantees maximum sensitivity and extreme fast response time.

- Measuring range from 50° to 1800°C
- $2.3\mu\text{m}$ wave length for measurements of metals, metal oxides, ceramic materials and shiny targets
- Short measuring wave length reduces error of temperature readings on surfaces with low or unknown emissivity
- Up to 125°C ambient temperature without cooling
- Precision optics (75:1/33:1/22:1) with different models for a specific focus point
- 1ms response time to capture fast events
- Fully programmable instrument for enhanced signal processing and I/O control
- Separate controller with easy accessible programming keys and multi colour LCD backlit display

Optical specifications thermoMETER CTM3

□ = smallest spot size (mm)

Standard Focus optics											
3SF22	22:1	7	9	18	27	36	45	55	64	73	
3SF33	33:1	7	7	12	18	24	30	36	42	48	
3SF75H1/H2/H3	75:1	7	7	7	8	11	14	17	20	23	
<i>distance in mm</i>		0	200	400	600	800	1000	1200	1400	1600	
Close Focus optics (integrated CF lens)											
3CF22	22:1	6.5	6	5.5	5	9.2	14.5	19.7	24.9	30.1	35.4
3CF33	33:1	6.5	5.4	4.2	3.4	6.9	11.4	15.9	20.4	24.8	29.3
3CF75H1/H2/H3	75:1	6.5	5	3.2	1.5	3.6	5.4	8.4	11.3	14.3	17.3
<i>distance in mm</i>		0	40	80	110	150	200	250	300	350	400

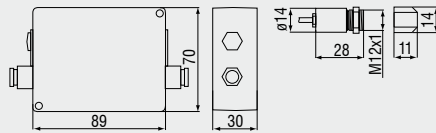

Product identification

CTM - 3 SF22 - C3

Cable length [3 m]
 Focus [SF22 / SF33 / SF75 / CF22 / CF33 / CF75]
 Spectral range [2.3 μm]
 thermoMETER CTM

Model	CTM-3SF22-C3	CTM-3SF33-C3	CTM-3SF75H1-C3	CTM-3SF75H2-C3	CTM-3SF75H3-C3
Optical resolution ¹	22:1	33:1	75:1	75:1	75:1
Temperature range ^{2,3}	50 to 400°C	100 to 600°C	150 to 900°C	200 to 1200°C	350 to 1800°C
Spectral range	2.3 μm				
System accuracy ^{4,5}	±(0.3% of reading +2°C)				
Repeatability ⁴	±(0.1% of reading +1°C)				
Temperature resolution (digital)	±0.1°C				
Response time ⁶	1 ms (90 %)				
Emissivity/gain ²	0.100 to 1.100				
Transmissivity/gain ²	0.100 to 1.100				
Signal processing ²	Peak hold, valley hold, average; extended hold function with threshold and hysteresis				
Certificate of calibration	optional				

Outputs/analogue	channel 1 channel 2	0/4 to 20 mA, 0 to 5/10 V, thermocouple J, K sensor temperature (-20 to 100 °C as 0 to 5 V or 0 to 10 V), alarm output
Outputs/analogue	optional	relay: 2 x 60 VDC/42 VAC _{eff} ; 0,4 A; optically isolated
Alarm output		open-collector (24 V / 50 mA)
Outputs/digital	optional	USB, RS232, RS485, CAN, Profibus DP, Ethernet
Output impedances	current output voltage output	relay max. 500 Ω (8 to 36 VDC) min. 100 kΩ load impedance; thermocouple 20 Ω
Inputs		programmable functional inputs for external emissivity adjustment, ambient temperature compensation, trigger (reset of hold functions)
Cable length		3 m
Power supply		8 to 36 VDC; max. 100 mA

Environmental rating		IP 65 (NEMA-4)
Ambient temperature		sensor: -40 °C to 85 °C controller: 0 °C to 85 °C
Storage temperature		sensor: -40 °C to 125 °C controller: -40 °C to 85 °C
Relative humidity		10 to 95 %, non condensing
Vibration	sensor	IEC 68-2-6: 3 G, 11 to 200 Hz, any axis
Shock	sensor	IEC 68-2-27: 50 G, 11 ms, any axis
Weight		sensor: 40 g; controller: 420 g

¹ 90 % energy

² adjustable via programming keys or software

³ target temperature > sensor temperature + 25°C

⁴ ± ambient temperature 23 ±5°C

⁵ E=1, response time 1 s

⁶ with dynamic adaption at low signal levels

Accessories page 46 - 49

- ▶ CF lens
- ▶ Protective window
- ▶ Mounting bracket / Mounting bolt
- ▶ Air purge collar
- ▶ Right angle mirror
- ▶ Rail mount adapter for controller
- ▶ Massive housing
- ▶ Protective tube
- ▶ Laser sighting tool
- ▶ Digital-Interface kit
- ▶ Software CompactConnect
- ▶ Certificate of calibration
- ▶ Relay output module

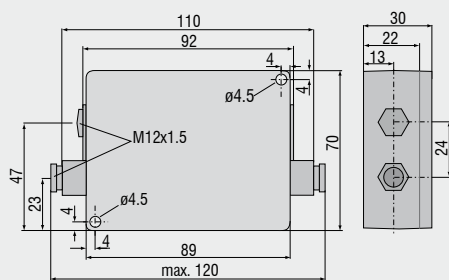
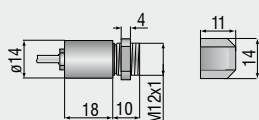
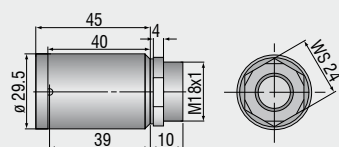
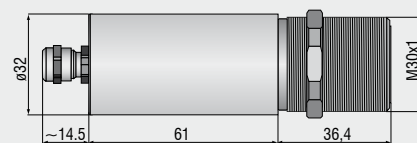
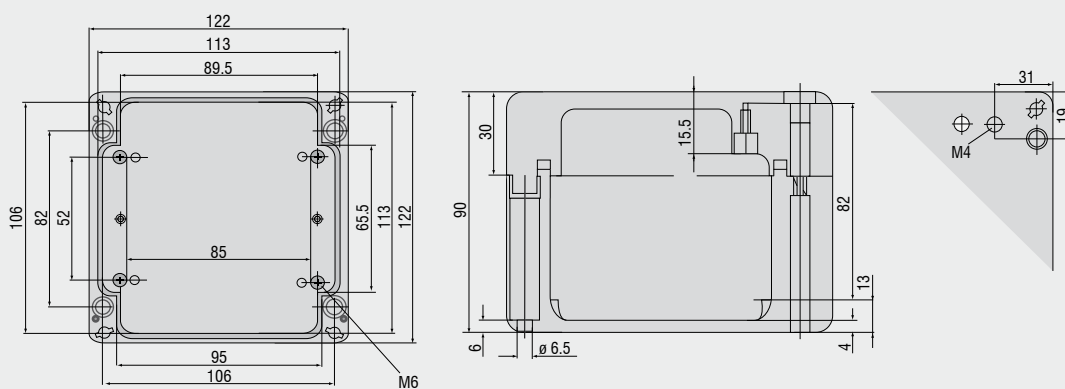
Controller**CT / CTfast / CTM1/M2/M3****CThot / CTP7****CTM3-XL****CTex**

Mechanical accessories

Art. No.	Model	
2970203	TM-FB-CT	Mounting bracket, fixed
2970325	TM-FB2-CT	Mounting bracket, adjustable in one axis, for simultaneous assembly of CT sensor and laser-sighting-tool
2970336	TM-FBMH-CT	Mounting bracket, adjustable in one axis, for massive housing
2970204	TM-AB-CT	Mounting bracket, adjustable in 2 axes
2970205	TM-MB-CT	Mounting bolt with M12x1 thread
2970206	TM-MG-CT	Mounting fork, adjustable in 2 axes, with thread M12x1
2970207	TM-AP-CT	Air purge collar from 10:1 optics
2970208	TM-AP2-CT	Air purge collar for 2:1 optic
2970209	TM-APL-CT	Air purge collar, laminar
2970210	TM-APLCF-CT	Air purge collar, laminar, with integral CF-lens
2970357	TM-APLCFH-CT	Air purge collar, laminar, with integral CF-lens for M1/M2/M3 sensors
2970211	TM-RAM-CT	Right angle mirror for 90°C measurements
2970212	TM-RAIL-CT	Rail mount adapter for CT controller
2970213	TM-COV-CT	Closed cover for controller
2970214	TM-MHS-CT	Massive housing, compact, stainless steel
2970215	TM-MHS-CF-CT	Massive housing, compact, stainless steel with integrated CF-lens
2970358	TM-MHSCFH-CT	Massive housing, compact, stainless steel with integrated CF-lens for M1/M2/M3 sensors
2970216	TM-MHA-CT	Massive housing, compact, anodized aluminium
2970217	TM-MHACF-CT	Massive housing, compact, anodized aluminium with integrated CF-lens
2970359	TM-MHACFH-CT	Massive housing, compact, anodized aluminium with integrated CF-lens for M1/M2/M3 sensors
2970218	TM-MHB-CT	Massive housing, compact, brass
2970219	TM-MHBCF-CT	Massive housing, compact, brass with integrated CF-lens
2970360	TM-MHBCFH-CT	Massive housing, compact, brass with integrated CF-lens for M1/M2/M3 sensors
2970220	TM-PT-CT	Protective tube, lang, brass
2970326	TM-PA-CT	Pipe adapter for sighting tube
2970327	TM-ST20-CT	Sighting tube, length 20 mm
2970328	TM-ST40-CT	Sighting tube, length 40 mm
2970329	TM-ST88-CT	Sighting tube, length 88 mm
2970221	TM-LST-CT	Laser sighting tool for CT sensors incl. batteries (2xalkaline cells AA)
2970300	TM-LSTOEM-CT	OEM Laser pointing device, 635 nm, rotation symmetrical, 3.5 m cable
2970300.008	TM-LSTOEM-CT(008)	OEM Laser pointing device, 635 nm, rotation symmetrical, 8m cable
2970222	TM-EX-CT	CTex-Kit: Accessory-Kit for use of the CT in hazardous locations according zone 1: PTB 01 ATEX 2053/ E II (1/2) G [Ex ia/ib] IIC/IIB, preassembled Ex-box without zener barriers, combinable with all standard CT SF sensors (except CTfast)

CTM3-XL

2970352	TM-FBXL-CT	Mounting bracket, adjustable in one axis
2970353	TM-ABXL-CT	Mounting bracket, adjustable in two axes
2970354	TM-APXL-CT	Air purge collar
2970361	TM-XLCERT-CT	Certificate of calibration

Optical accessoires

Art. No.	Model	
2970201	TM-CF-CT	CF-lens (SF sensors only)
2970202	TM-PW-CT	Protective window (SF sensors only)
2970297	TM-CFAG-CT	Lens with external thread
2970330	TM-CFH-CT	Lens for M1/M2/M3 sensors
2970331	TM-CFHAG-CT	Lens with external thread for M1/M2/M3 sensors
2970299	TM-PWAG-CT	Protective window with external thread
2970332	TM-PWH-CT	Protective window for M1/M2/M3 sensors
2970333	TM-PWHAG-CT	Protective window with external thread for M1/M2/M3 sensors

Interfaces

2970223	TM-USBK-CT	USB interface kit incl. computer cable, software CompactConnect
2970224	TM-RS232K-CT	RS232 interface kit incl. computer cable, software CompactConnect
2970338	TM-RS485USBK-CT	RS485-USB-adapter, incl. PC cable, software CTconnect, terminal block, for use with TM-485B-CT
2970227	TM-CANK-CT	CAN-Bus interface for oprtris CT/ protocol: CANopen Presettings: module address 20 (14H), 250kBaud, 0-60°C
2970228	TM-PFBDPK-CT	Profibus-DPv1 interface for CT selectable with DIN M12 or SUB-D connection
2970229	TM-ETHNK-CT	Profibus-DPv1 interface for CT selectable with DIN M12 or SUB-D connection
2970230	TM-RI-CT	Relay interface: Two optically isolated relays, 60VDC/ 42VACRMS, 0,4A
2970226	TM-RS485B-CT	RS485 interface

Calibration

2970231	TM-CERT-CT	Certificate of calibration acc. ISO9001: testing procedure with defined ambient temperatures, target dimensions and distances; Test temperatures 20°C/ 100°C/ 500°C
2970310	TM-HTCERT-CT	Certificate of calibration for CTM sensors



TM-FB-CT Mounting bracket, fixed

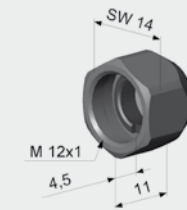

TM-CF-CT Close Focus Lens (SF sensors only)

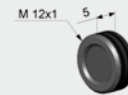

TM-CFAG-CT CF lens with external thread resp.
TM-PWAG-CT Protective window with external thread



TM-AB-CT Mounting gimble, adjustable in two axes

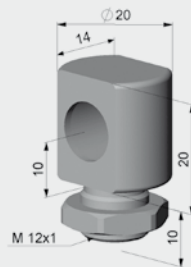

TM-MB-CT Mounting bolt with M12x1 thread adjustable

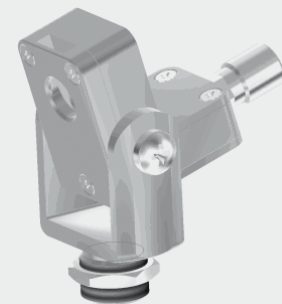

TM-APL-CT Laminar air purge collar and
TM-MG-CT Mounting fork



TM-MG-CT Mounting fork with M 12x1 thread adjustable in two axes

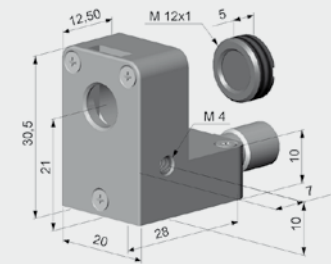

TM-APLCF-CT
CF lense/ protective window - integral
option for air purge collar

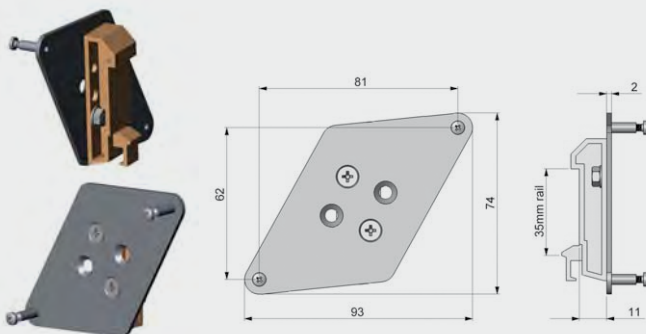

TM-RAIL-CT Rail mount adapter for controller

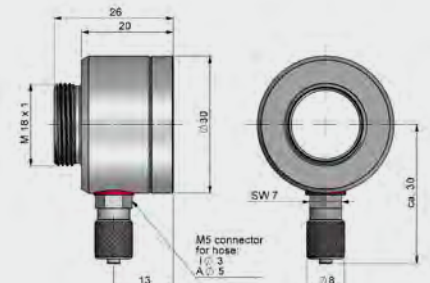

TM-AP-CTR Air purge collar



TM-PA-CT Pipe adapter for sighting tube

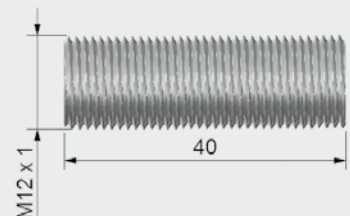

TM-ST40-CT Sighting tube



TM-LST-CT Laser-Sighting tool

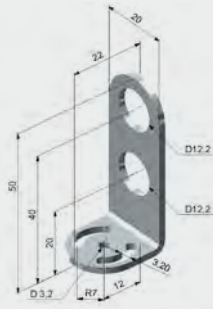

TM-FB2-CT
Laser-Sighting mounting bracket



TM-RAM-CT Right angle mirror

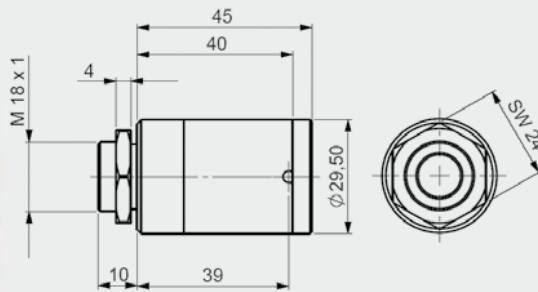

TM-MHS-CT Massive housing, compact, stainless steel
 TM-MHA-CT Massive housing, compact, aluminium
 TM-MHB-CT Massive housing, compact, brass



The lens must be kept clean at all times from dust, smoke, fumes and other contaminants in order to avoid reading errors. These effects can be reduced by using an air purge collar.

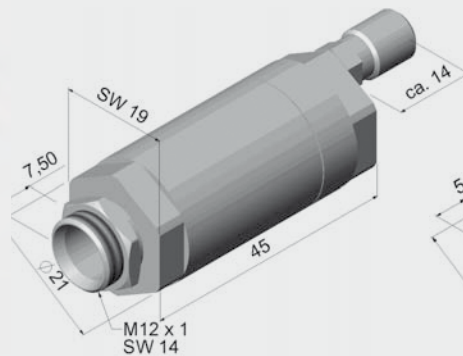

TM-AP-CT Standard air purge collar for 10:1 / 15:1 / 22:1 optics

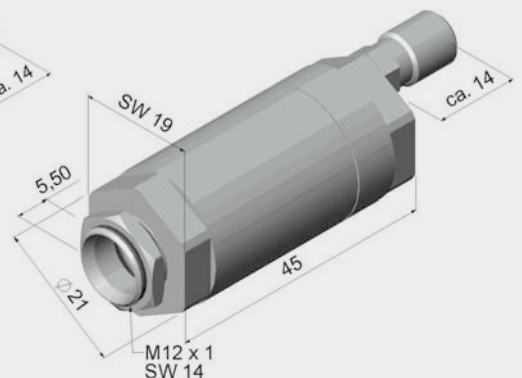

TM-AP2-CT Standard air purge collar for 2:1 optics