



### thermoMETER CSmicro

This non contact infrared temperature sensor is the world's smallest IR instrument. With just the compact optical head left, this instrument is perfect for the integration in space restricted applications. The electronic is miniaturized and integrated inside the sensor cable. The CSmicro is fully programmable and is available in four basic models, where each has a unique feature to succeed in the most challenging applications.

- Measuring range from -30 to 1600°C
- Robust precision silicon optics with AR coating
- Integrated controller with LED alarm indicator and smart electronic sighting support, selfdiagnostic or temperature code indication
- Up to 125°C ambient temperature without cooling
- Micro electronics integrated into the cable, field programmable; adjustable emissivity
- Analogue output: 0 - 10V or 0 - 5V, 2wire current option, alarm output
- Short circuit and reverse polarity protection
- 8...14μm spectrum or short wavelength model with 1.6μm
- Optional USB programming interface and software

### Optical specifications thermoMETER CSmicro

□ =smallest spot size (mm)

Standard focus optics										
<b>SF02</b>	<b>2:1</b>	5	50	100	150	200	250	300	350	400
<b>SF15</b>	<b>15:1</b>	7	8	13	20	27	33	40	47	53
distance (mm)		0	100	200	300	400	500	600	700	800
<b>SF75</b>	<b>75:1</b>	7	7	7	8	11	14	17	20	23
distance (mm)		0	200	400	600	800	1000	1200	1400	1600
Close focus optics (CF lense optional available)										
<b>CF02</b>	<b>2:1</b>	7	5.6	4.3	3	2.5	2.4	3	4.7	6.3
<b>CF15</b>	<b>15:1</b>	7	5	0.8	5	11	16	21	27	32
distance (mm)		0	5	10	15	20	25	30	35	40
Close focus optics (Integrated CF lense in the sensor head)										
<b>CF75</b>	<b>75:1</b>	6.5	3.8	1.5	4.4	8.1	11.7	15.4	19	22.6
distance (mm)		0	60	110	150	200	250	300	350	400

## Product identification

CSmi - SF10 - C1

Cable length  
Fokus [SF / CF]  
thermoMETER CSmi  
thermoMETER CSmi2W (TwoWire sensor)

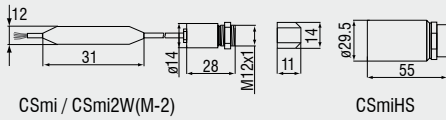

Model	CSmi-SF02-C1	CSmi-SF15-C1	CSmiHS-SF15-C4	CSmi2W-SF15-C1	CSmi2WM-2SF75-C1
Optical resolution	2:1	15:1	15:1	15:1	75:1
Temperature range	-40°C to 1030°C <sup>1</sup>		-20°C to 150°C	-40°C to 1030°C <sup>1</sup>	385°C to 1600°C <sup>1</sup>
Spectral range	8 to 14µm		8 to 14µm	8 to 14µm	1.6µm
System accuracy	±1.5% or ±1.5°C <sup>3</sup>		±1.0% or ±1.0°C <sup>5</sup>	±1.0% or ±1.5°C <sup>3</sup>	±(0.3% of reading + 2°C) <sup>4</sup>
Repeatability	±0.75% or ±0.75°C <sup>3</sup>		±0.3% or ±0.3°C <sup>5</sup>	±0.75% or ±0.75°C <sup>3</sup>	±(0.1% of reading + 1°C) <sup>4</sup>
Temperature coefficient	± 0.05 K/K or ± 0.05% K				
Temperature resolution	0.15°C <sup>7</sup>		0.025°C <sup>7</sup>	0.1°C <sup>7</sup>	0.1°C
Response time (90%)	30ms (adjustable up to 999s via optional programming device)		150ms (adjustable up to 999s via optional programming device)	30ms	10ms
Emissivity/gain	0.100 to 1.100 <sup>2</sup>		0.100 to 1.100 <sup>1</sup>		
Transmissivity/gain <sup>1</sup>	0.100 to 1.100				
Signal processing <sup>1</sup>	peak hold, valley hold, average; extended hold function with threshold and hysteresis				
Dimensions controller	length 35mm; ø12mm				
Outputs/analogue	0 to 5V or 0 to 10V 1/10/100 mV/°C		4 to 20mA		
Loop resistance	-		1000Ω <sup>9</sup>		
Outputs/alarm	Alarm (50mA / 24V)		0-30V / 500mA (open collector)		
Outputs/digital (optional)	USB				
Inputs	programmable functional input for external emissivity adjustment (0 - 5VDC), hold function or USB communication		programmable functional input for triggered signal output or peak-hold function		
LED functions	alarm indication, automatic aiming support, self diagnostic, temperature indication (via temp. code)				
Cable length	1m (standard); 0.5m between sensor and controller; 0.4m between controller and terminal		<b>4m (0.5m sensor-controller) sensor with massive housing TM-MHS-CT ø29.5mm x 55mm</b>	1m (standard); 0.5m between sensor and controller; 0.4m between controller and terminal	
Power supply	9mA (5 to 30VDC)		4...20mA (5 to 30VDC)		
Environmental rating	IP 65 (NEMA-4) sensor head				
Ambient temperature	Sensor: -20°C to 120°C Controller: -20°C to 80°C		Sensor: -20°C to 75°C Controller: -20°C to 75°C	Sensor: -20°C to 120°C Controller: -20°C to 75°C	Sensor: -20°C to 125°C Controller: -20°C to 75°C
Storage temperature	-40°C to 85°C (sensor and controller)				
Relative humidity	10 - 95%, non condensing				
Vibration	IEC 68-2-6: 3 G, 11-200Hz, any axis				
Shock	IEC 68-2-27: 50 G, 11ms, any axis				
Weight	42g		200g	42g	

<sup>1</sup> adjustable via software<sup>2</sup> adjustable via 0 - 5VDC input or software<sup>3</sup> ± at ambient temperature 23±5°C; object temperature >0°C; whichever is greater<sup>4</sup> Epsilon = 1, response time 1s; object temperature >450°C<sup>5</sup> at ambient temperature 23±5°C; object temperature >20°C; whichever is greater<sup>6</sup> object temperature <100°C; and time constant >0.2s<sup>7</sup> object temperature > 20°C; and time constant >0.2s<sup>9</sup> in dependence on supply voltage

## Accessories page 60 - 61

- ▶ CF lens
- ▶ Protective window
- ▶ Mounting bracket / Mounting bolt
- ▶ Air purge collar
- ▶ Right angle mirror
- ▶ Software CompactConnect
- ▶ USB Kit

**CSLaser**

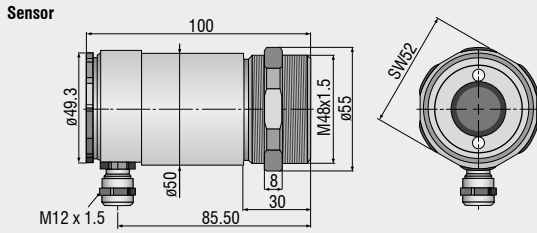

**CS**

sensor with integrated controller

CF lens

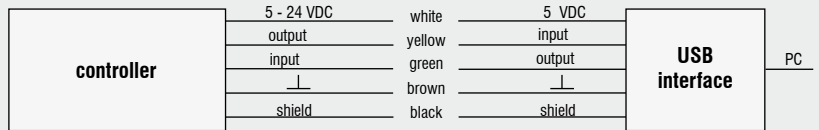
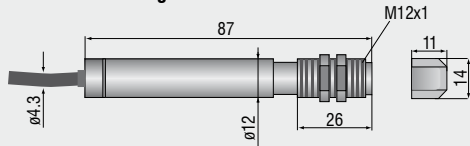

**CSmicro**

CF lens

sensor

~0.5 m

31 mm

controller inside cable

~0.4 m

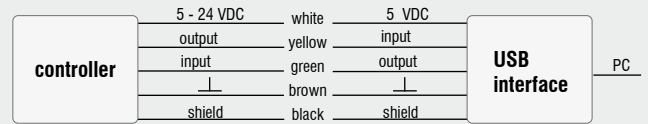
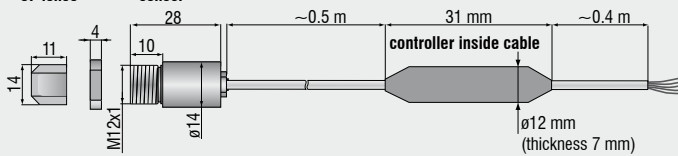

**CX**

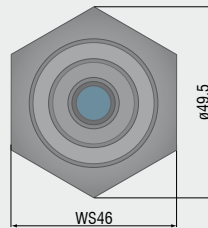
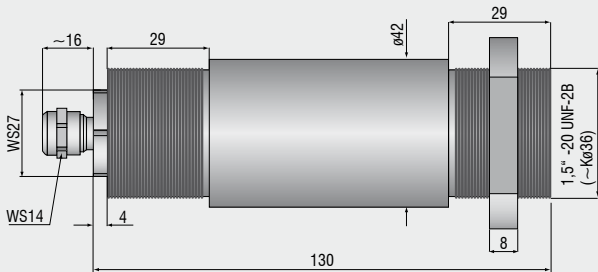

**Mechanical accessories CS / CSmicro**

Art. No.	Model	Description
2970279	TM-FB-CS	Mounting bracket, fixed
2970280	TM-AB-CS	Mounting bracket, adjustable
2970281	TM-MB-CS	Mounting bolt with M12x1 thread
2970282	TM-MG-CS	Mounting fork, adjustable in 2 axes, with thread M12x1
2970283	TM-AP-CS	Air purge collar for 10:1 sensors
2970284	TM-APL-CS	Air purge collar, laminar
2970285	TM-APLCF-CS	Air purge collar, laminar, integrated CF-lens
2970286	TM-RAM-CS	Right angle mirror for 90°C measurements
2970287	TM-USBK-CS	USB interface kit incl. software CompactConnect

**Optical accessories CS / CSmicro**

2970277	TM-CF-CS	CF-Lens for CS series
2970278	TM-PW-CS	Protective window for CS series

**Calibration CS / CSmicro**

2970288	TM-CERT-CS	Certificate of calibration
---------	------------	----------------------------

**Mechanical accessories CX**

Art. No.	Model	Description
2970307	TM-AP-CX	Air purge collar, aluminium (anodized)
2970321	TM-FB-CX	Mounting bracket, adjustable in one axis, stainless steel
2970322	TM-AB-CX	Mounting bracket, adjustable in two axes, stainless steel
2970311	TM-USBK-CX	USB-Kit: USB programming adapter, Software CompactConnect

**Optical accessories CX**

2970302	TM-CF-CX	CF-lens for thermoMETER CX
2970303	TM-PW-CX	Protective window for thermoMETER CX

**Calibration CX**

2970323	TM-CERT-CX	Certificate of calibration
---------	------------	----------------------------

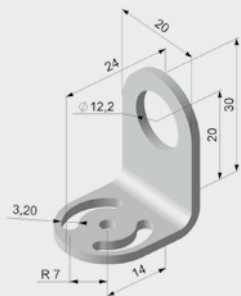

TM-FB-CS Mounting bracket, fixed

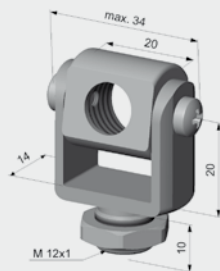

TM-MG-CS Mounting fork with M 12x1 thread adjustable in two axes

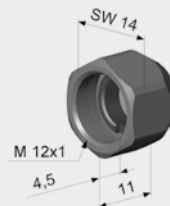

TM-CF-CS Close Focus Lens (LT sensors only)

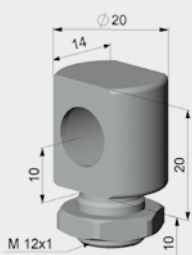

TM-MB-CS Mounting bolt with M12x1 thread adjustable

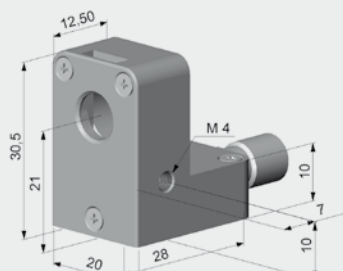

TM-APL-CS Air purge collar

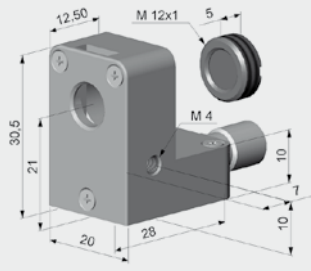

TM-APLCF-CS Air purge collar, laminar, integrated CF-lens

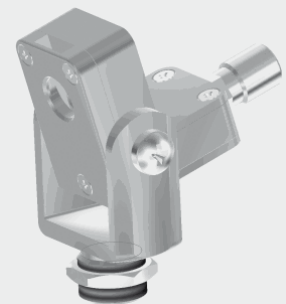

TM-APL-CS Laminar air purge collar and TM-MG-CS Mounting fork

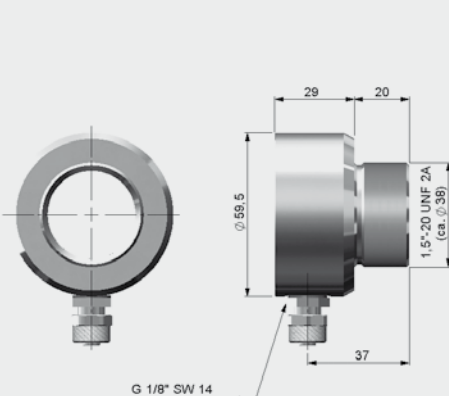

TM-AP-CX Air purge collar CX sensors

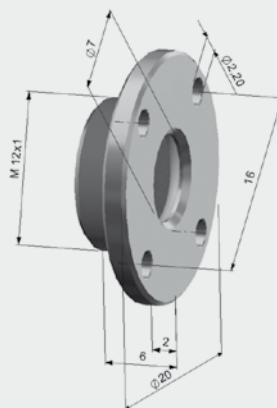

TM-CF-CX CF-Lens  
TM-PW-CX Protective window

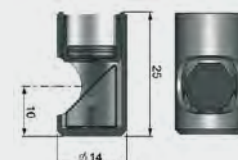

TM-RAM-CS Right angle mirror