

Pressure measurement

Pressure transmitters

for food, pharmaceuticals and biotechnology / SITRANS P300

Overview



The SITRANS P300 is a digital pressure transmitter for relative and absolute pressure. The conventional thread versions are available as process connections, as are flush-mounted versions. A large number of the flush-mounted versions are suitable for food and pharmaceutical applications, and satisfy the EHEDG and 3A hygiene requirements.

The output signal is a load-independent direct current from 4 to 20 mA or a PROFIBUS PA or FOUNDATION Fieldbus signal, which is linearly proportional to the input pressure. Communication is via HART protocol or PROFIBUS PA or FOUNDATION Fieldbus interface. The basic settings of the pressure transmitter can be made easily on-site by means of three buttons.

The SITRANS P300 has a single-chamber stainless steel enclosure. The pressure transmitter is approved for "intrinsically safe" type of protection. It can be used in zone 1 or zone 0.

Benefits

- High quality and service life
- High reliability even under extreme chemical and mechanical loads
- Extensive diagnostics and simulation functions
- Minimal conformity error
- Small long-term drift
- Wetted parts made of high-grade materials (e.g., stainless steel, Hastelloy)
- Measuring range 0.008 bar to 400 bar (0.1 psi to 5802 psi)
- High measuring accuracy
- Parameterization using control keys and HART and/or PROFIBUS PA or FOUNDATION Fieldbus

Application

The pressure transmitter is available in versions for gauge pressure and for absolute pressure. The output signal is always a load-independent direct current from 4 to 20 mA or a PROFIBUS PA or FOUNDATION Fieldbus signal, which is linearly proportional to the input pressure. The pressure transmitter measures corrosive, non-corrosive and hazardous gases, vapors and liquids.

It can be used for the following measurement types:

- Gauge pressure
- Absolute pressure

With appropriate parameter settings, it can also be used for the following additional measurement types:

- Level
- Volume
- Mass

The "intrinsically safe" Ex ia type of protection version of the transmitter can be installed in hazardous areas (Zone 1). The devices are provided with an EC type-examination certificate and comply with the respective harmonized European standards of ATEX.

Gauge pressure

This variant measures the gauge pressure of corrosive, non-corrosive and hazardous gases, vapors and liquids.

The smallest measuring span is 0.01 bar (0.15 psi), the largest 400 bar (5802 psi).

Level

With appropriate parameter settings, the gauge pressure variant measures the level of corrosive, non-corrosive and hazardous liquids.

For level measurement in an open vessel, you require one device; for level measurement in a closed vessel, you require two devices and a process control system.

Absolute pressure

This variant measures the absolute pressure of corrosive, non-corrosive and hazardous gases, vapors and liquids.

The smallest measuring span is 0.008 bar a (0.12 psi a), the largest is 30 bar a (435 psi a).

Design

The device comprises:

- electronics
- Enclosure
- Measuring cell

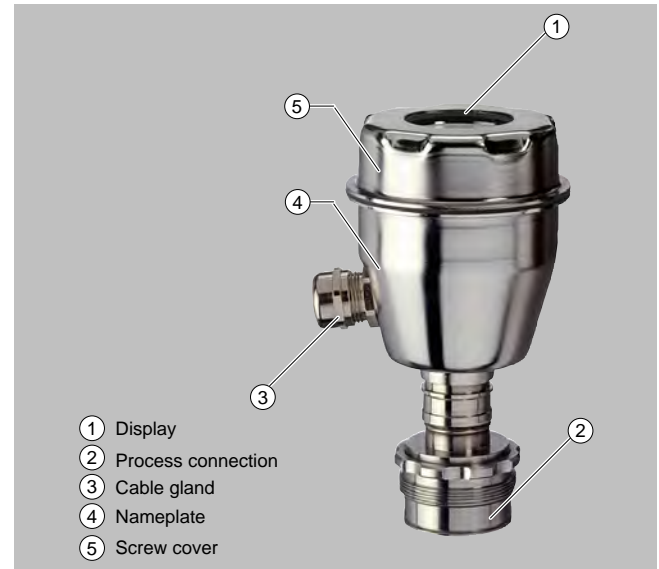

Perspective view of SITRANS P300

The enclosure has a screw-on cover (5) and, depending on the version, comes with or without an inspection window. The electrical terminal compartment, the buttons for operation of the device are located under this cover and, depending on the version, the display. The connections for the auxiliary power U_H and the shield are in the terminal compartment. The cable gland is mounted on the side of the enclosure. The measuring cell with the process connection (2) is located on the bottom of the enclosure. The measuring cell with the process connection may differ from the one shown in the diagram, depending on the device version.

Example of attached measuring points sign

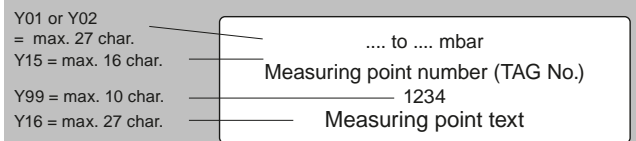

Pressure measurement

Pressure transmitters

for food, pharmaceuticals and biotechnology / SITRANS P300

Function

Mode of operation of electronics with HART communication

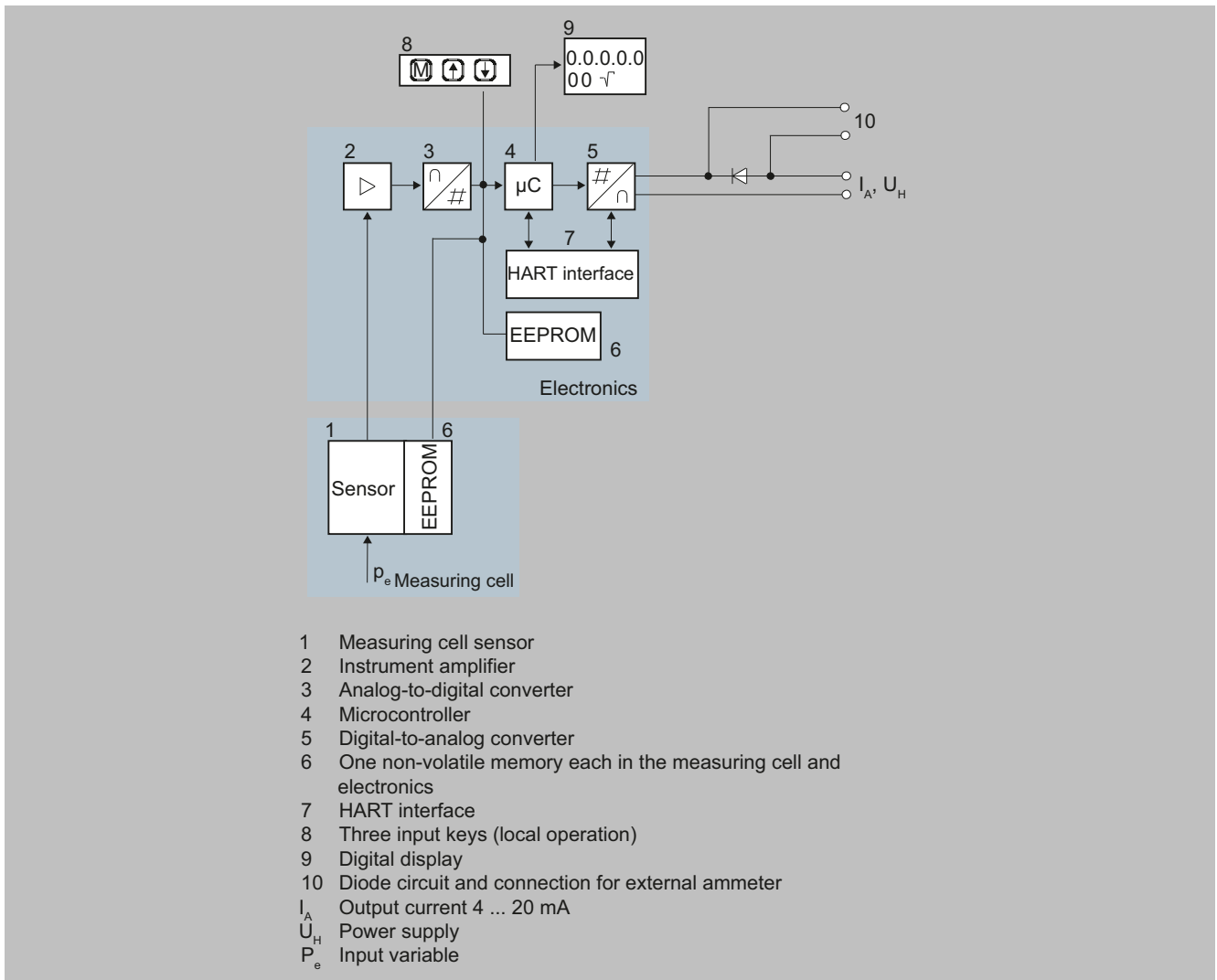

Function diagram of electronics

The input pressure is converted into an electrical signal by the sensor (1). This signal is amplified by the instrument amplifier (2) and digitalized in an analog-to-digital converter (3). The digital signal is analyzed in a microcontroller (4) and corrected for linearity and temperature response. In a digital-to-analog converter (5) it is then converted into the output current of 4 to 20 mA. A diode circuit provides reverse polarity protection. You can make an uninterrupted current measurement with a low-ohm ammeter at the connection (10). The data specific to the measuring cell, the electronic data and parameter settings are stored in two non-volatile memories (6). The first storage is linked to the measuring cell, the second to the electronics.

The buttons (8) can be used to call up individual functions, so-called modes. If you have a device with a local display (9), you can use this to track mode settings and other messages. The basic mode settings can be changed with a computer via the HART modem (7).

Function (continued)

Mode of operation of electronics with PROFIBUS PA communication

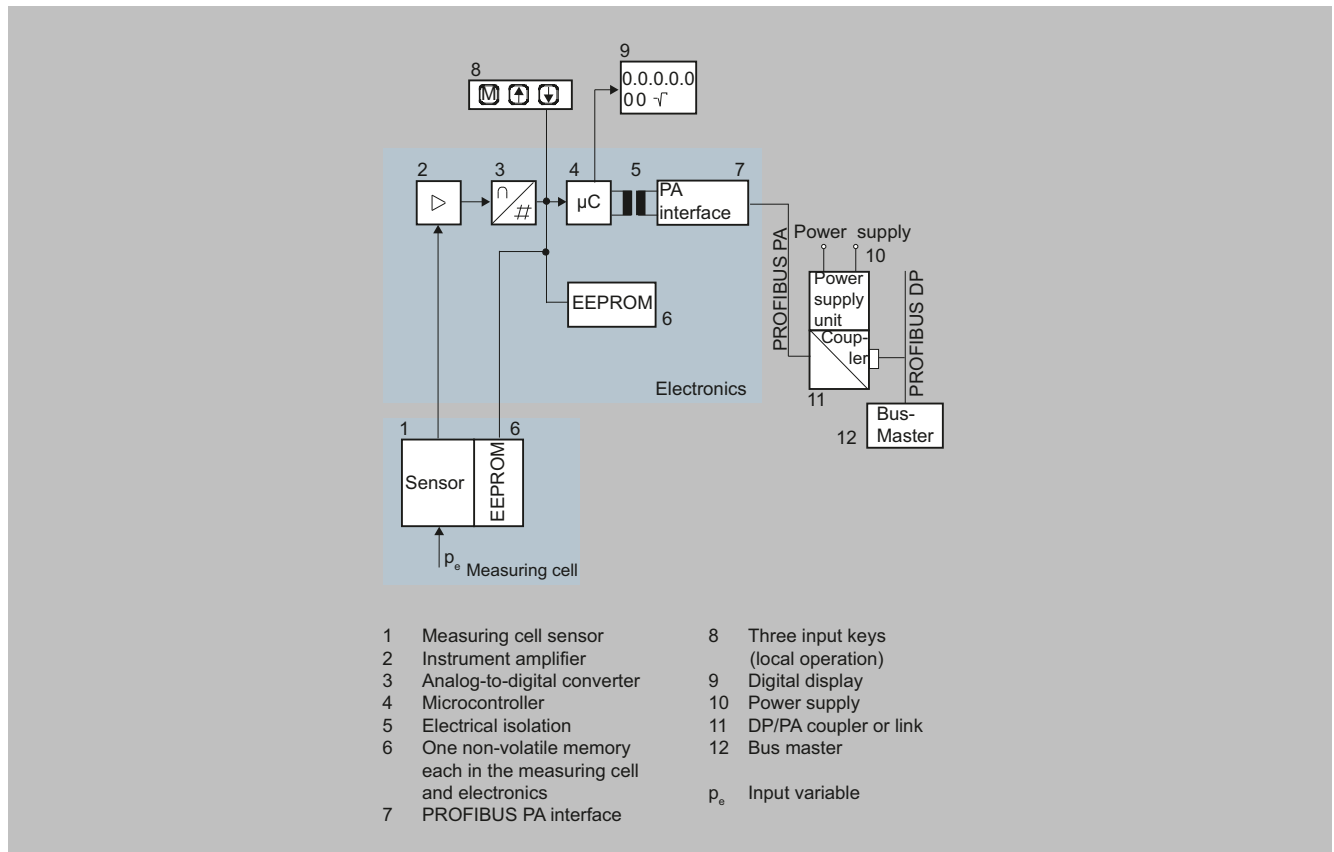

Function diagram of electronics

The input pressure is converted into an electrical signal by the sensor (1). This signal is amplified by the instrument amplifier (2) and digitalized in an analog-to-digital converter (3). The digital signal is analyzed in a microcontroller (4) and corrected for linearity and temperature response. It is then made available on the PROFIBUS PA via an electrically isolated PROFIBUS PA interface (7). The data specific to the measuring cell, the electronic data and parameter settings are stored in two non-volatile memories (6). The first storage is linked to the measuring cell, the second to the electronics.

The buttons (8) can be used to call up individual functions, so-called modes. If you have a device with a local display (9), you can use this to track mode settings and other messages. The basic mode settings can be changed with a computer over the bus master (12).

Pressure measurement

Pressure transmitters

for food, pharmaceuticals and biotechnology / SITRANS P300

Function (continued)

Mode of operation of electronics with FOUNDATION Fieldbus communication

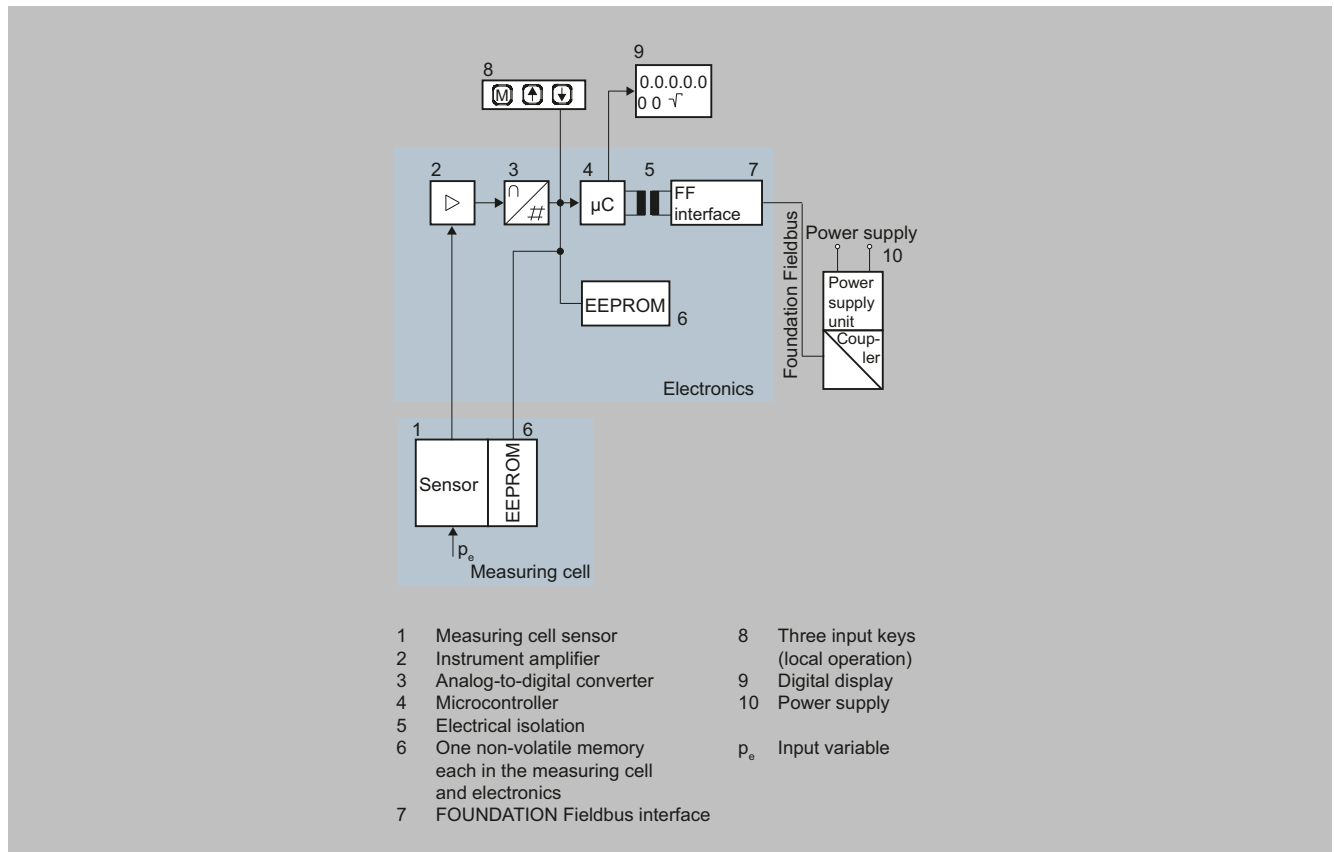

Function diagram of electronics

The bridge output voltage created by the sensor (1, Figure "Function diagram of electronics") is amplified by the instrument amplifier (2) and digitalized in the analog-to-digital converter (3). The digital information is evaluated in the microcontroller, corrected for linearity and temperature response and made available on the FOUNDATION Fieldbus via an electrically isolated FOUNDATION Fieldbus interface (7).

The data specific to the measuring cell, the electronics data, and the parameter data are stored in the two non-volatile memories (6). One storage is coupled to the measuring cell, the other to the electronics. As the result of this modular design, the electronics and the measuring cell can be replaced separately from each other.

Using the three input keys (8), you can assign parameters to the pressure transmitter directly at the measuring point. The input keys can also be used to control the view of the measurement results, the error messages and the operating modes on the local display (9).

The results with status values and diagnostics data are transferred by cyclic data transmission on the FOUNDATION Fieldbus. Parameterization data and error messages are transferred by acyclic data transmission. Special software such as National Instruments Configurator is required for this.

Mode of operation of the measuring cells

The process connections available include the following:

- G½
- ½-14 NPT
- Flush-mounted diaphragm:
 - Flanges according to EN
 - Flanges according to ASME
 - NuG and pharmaceutical connections

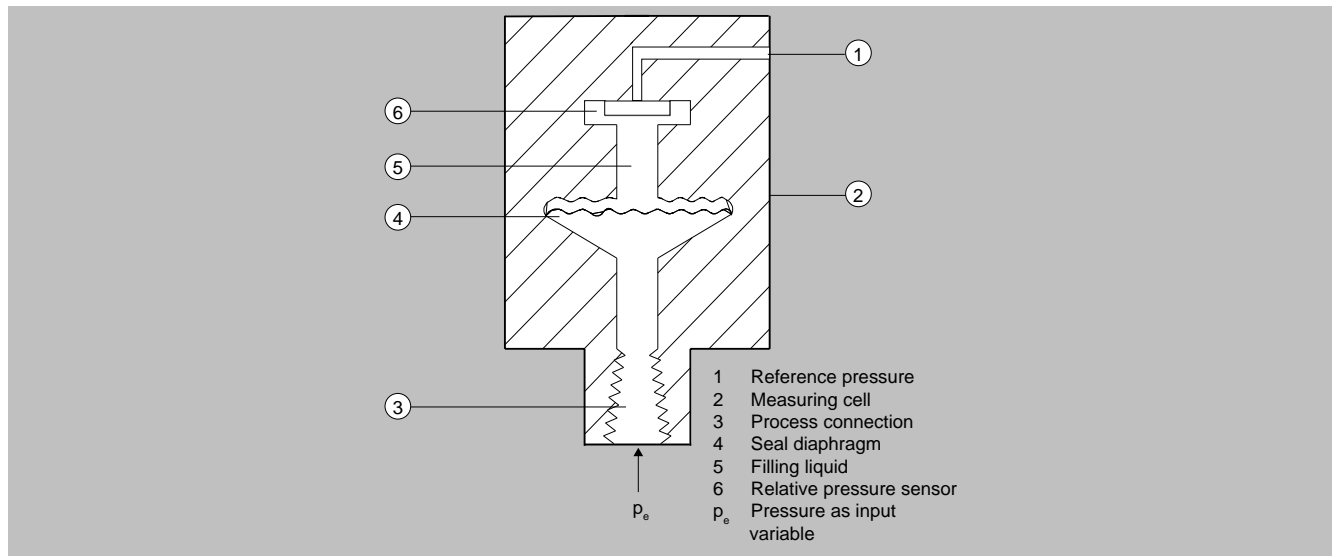
Function (continued)Measuring cell for gauge pressure

Measuring cell for gauge pressure, function diagram

The input pressure (p_e) is transferred via the seal diaphragm (4) and the filling liquid (5) to the gauge pressure sensor (6), displacing its measuring diaphragm. The displacement changes the resistance value of the four piezo resistors in the measuring diaphragm in a bridge circuit. The change in the resistance causes a bridge output voltage proportional to the input pressure.

Transmitters with measuring spans ≤ 63 bar (≤ 926.1 psi) measure the input pressure compared to atmospheric, transmitters with measuring spans of ≥ 160 bar (≥ 2352 psi) compared to a vacuum.

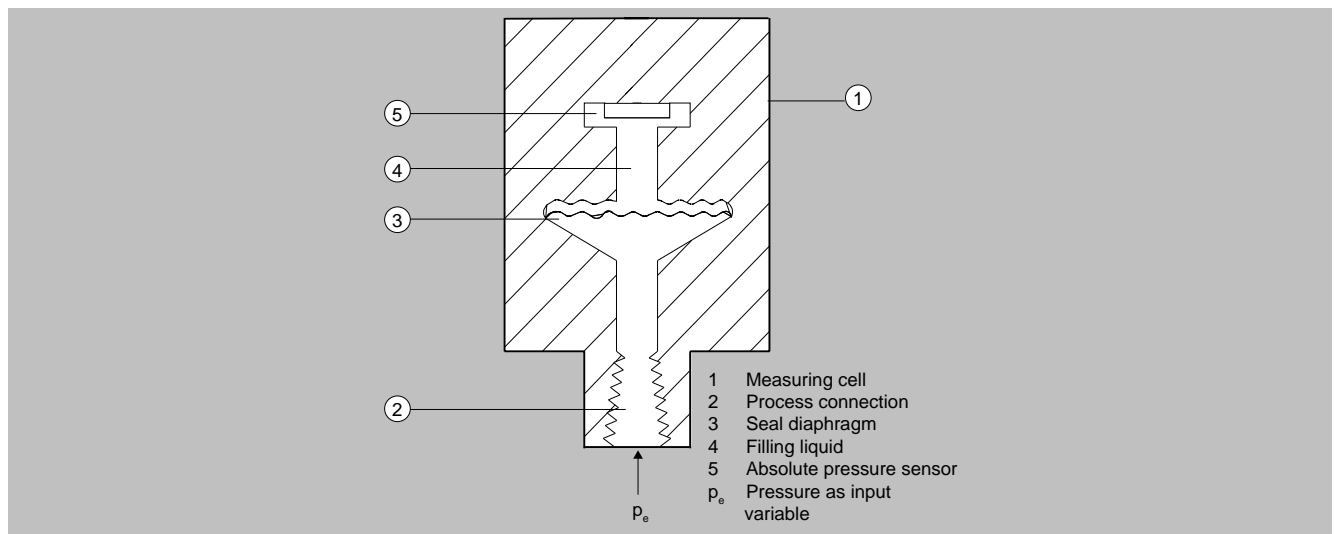
Measuring cell for absolute pressure

Measuring cell for absolute pressure, function diagram

The input pressure (p_e) is transferred via the seal diaphragm (3) and the filling liquid (4) to the absolute pressure sensor (5), displacing its measuring diaphragm. The displacement changes the resistance value of the four piezo resistors in the measuring diaphragm in a bridge circuit. The change in the resistance causes a bridge output voltage proportional to the input pressure.

Pressure measurement

Pressure transmitters

for food, pharmaceuticals and biotechnology / SITRANS P300

Function (continued)

Measuring cell for gauge pressure, flush-mounted diaphragm

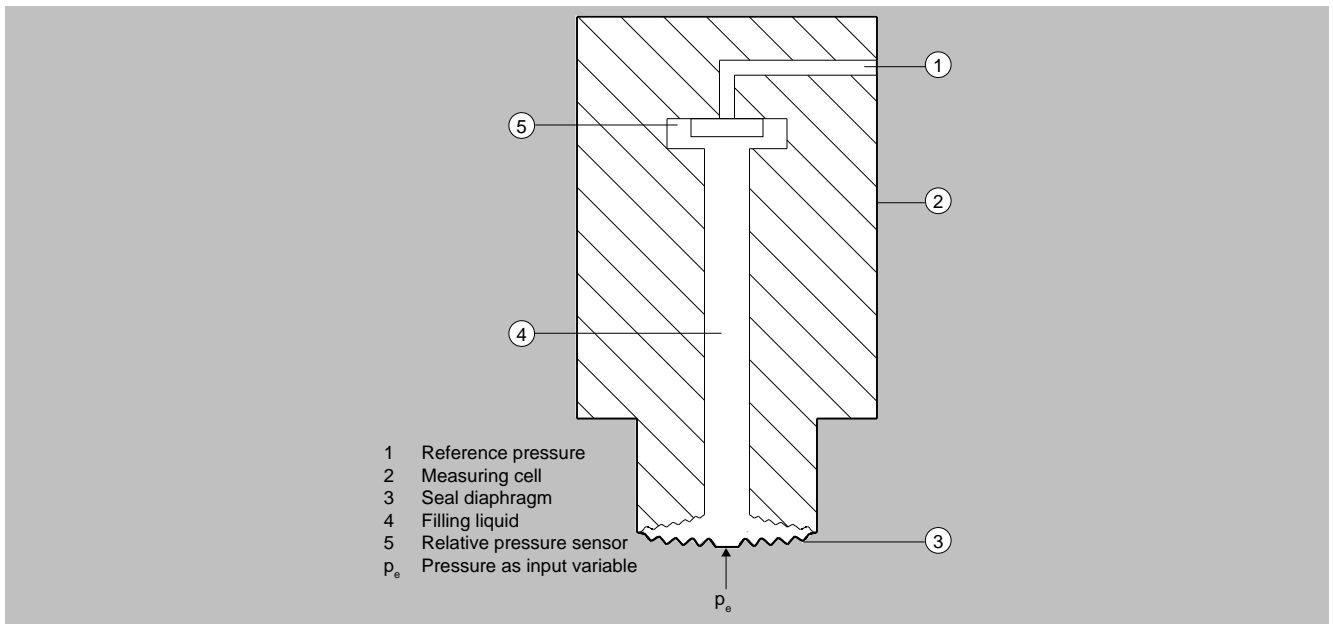

Measuring cell for gauge pressure, flush-mounted diaphragm, function diagram

The input pressure (p_e) is transferred via the seal diaphragm (3) and the filling liquid (4) to the gauge pressure sensor (5), displacing its measuring diaphragm. The displacement changes the resistance value of the four piezo resistors in the measuring diaphragm in a bridge circuit. The change in the resistance causes a bridge output voltage proportional to the input pressure.

Transmitters with measuring spans ≤ 63 bar (≤ 926.1 psi) measure the input pressure compared to atmospheric, transmitters with measuring spans of ≥ 160 bar (≥ 2352 psi) compared to a vacuum.

Measuring cell for absolute pressure, front-flush membrane

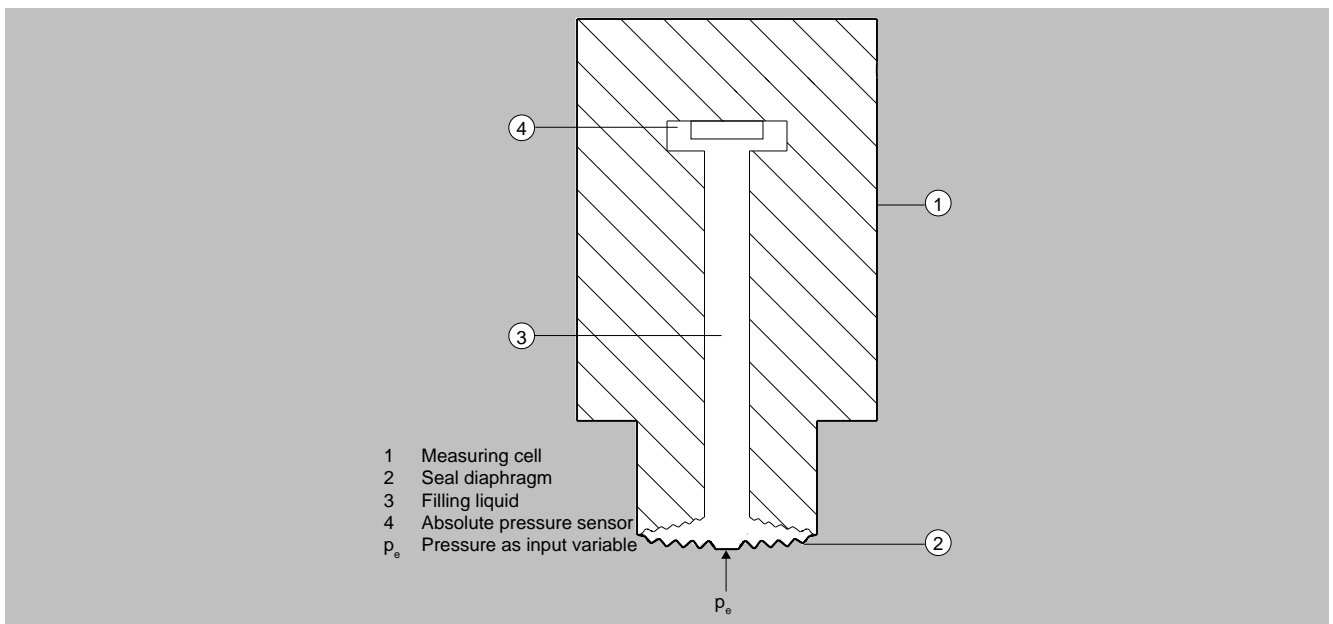

Measuring cell for absolute pressure, flush-mounted diaphragm, function diagram

Function (continued)

The input pressure (p_e) is transferred via the seal diaphragm (2) and the filling liquid (3) to the absolute pressure sensor (4), displacing its measuring diaphragm. The displacement changes the resistance value of the four piezo resistors in the measuring diaphragm in a bridge circuit. The change in the resistance causes a bridge output voltage proportional to the input pressure.

Parameterization

Depending on the version, there are a range of options for parameterizing the pressure transmitter and for setting or scanning the parameters.

Parameterization using the input keys (local operation)

With the input keys, you can easily set the most important parameters without any additional equipment.

Parameterization using HART

Parameterization using HART is performed with a HART Communicator or a PC.

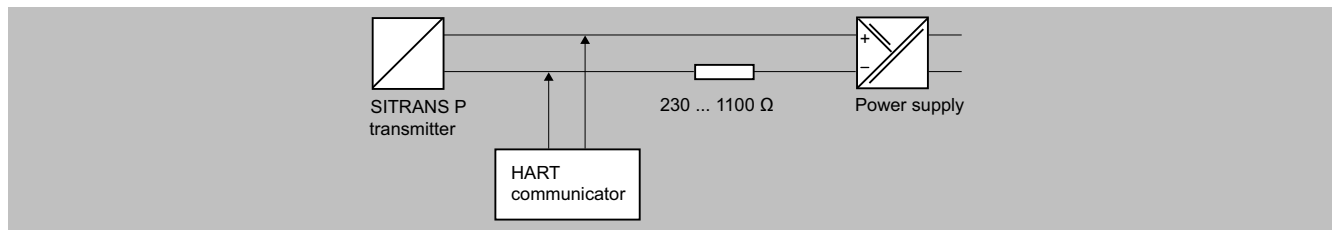

Communication between a HART Communicator and a pressure transmitter

When parameterizing with the HART Communicator, the connection is made directly to the 2-wire cable.

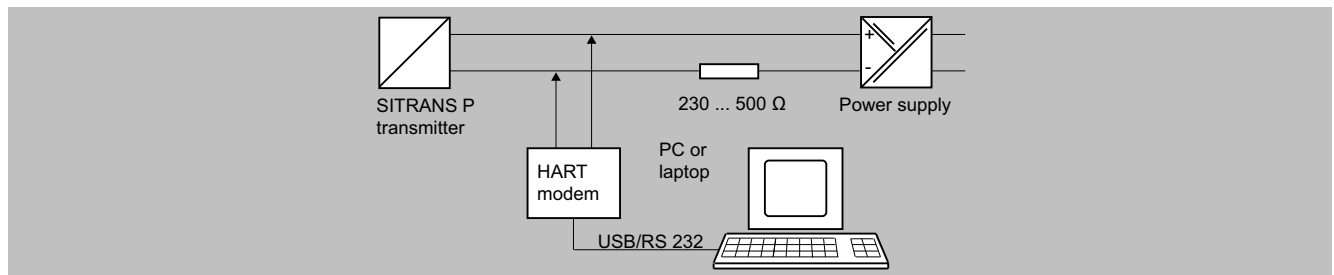

HART communication between a PC communicator and a pressure transmitter

When parameterizing with a PC, the connection is made through a HART modem.

The signals needed for communication in conformity with the HART 5.x or 6.x protocols are superimposed on the output current using FSK (Frequency Shift Keying).

Adjustable SITRANS P300 parameters with HART

Parameters	Input keys	HART
Lower range value	x	x
Upper range value	x	x
Electrical damping	x	x
Blind adjustment of the lower range value	x	x
Blind adjustment of the upper range value	x	x
Zero adjustment	x	x
Current simulator	x	x
Fault current	x	x
Disabling of buttons, write protection	x	x ¹⁾
Type of unit, unit	x	x
Input of characteristic curve		x
Freely-programmable LCD		x
Diagnostic functions		x

¹⁾ Except cancel write protection.

Diagnostic functions for SITRANS P300 with HART

- Zero correction display
- Event counter

Pressure measurement

Pressure transmitters

for food, pharmaceuticals and biotechnology / SITRANS P300

Function (continued)

- Limit transmitter
- Saturation alarm
- Min/max pointer
- Simulation functions
- Maintenance timer

Available physical units of display for SITRANS P300 with HART

Physical variable	Physical units
Pressure (can also be preset in the factory)	Pa, MPa, kPa, bar, mbar, torr, atm, psi, g/cm ² , kg/cm ² , in H ₂ O, in H ₂ O (4 °C), mmH ₂ O, ftH ₂ O (20 °C), inHg, mmHg
Level (height data)	m, cm, mm, ft, in
Volume	m ³ , dm ³ , hl, yd ³ , ft ³ , in ³ , US gallon, Imp. gallon, bushel, barrel, barrel liquid
Mass	g, kg, t, lb, Ston, Lton, oz
Temperature	K, °C, °F, °R
Other	%, mA

Parameterization through PROFIBUS interface

Fully digital communication through PROFIBUS PA, profile 3.0, is particularly user-friendly. PROFIBUS connects the SITRANS P300 PA to a process control system, e.g. SIMATIC PSC 7. Communication is possible even in a hazardous area.

For parameter assignment via PROFIBUS, you need suitable software, e.g. SIMATIC PDM (Process Device Manager)

Parameterization through FOUNDATION Fieldbus interface

Fully digital communication through FOUNDATION Fieldbus is particularly user-friendly. Through the FOUNDATION Fieldbus the P300 is connected to a process control system. Communication is possible even in a hazardous area.

For parameterization through the FOUNDATION Fieldbus you need suitable software, e.g. National Instruments Configurator.

Adjustable parameters for SITRANS P300 with PROFIBUS PA and FOUNDATION Fieldbus

Adjustable parameters	Input keys	PROFIBUS PA and FOUNDATION Fieldbus
Electrical damping	x	x
Zero adjustment (correction of position)	x	x
Buttons and/or function disabling	x	x
Source of measured value display	x	x
Physical unit of display	x	x
Position of decimal point	x	x
Bus address	x	x
Adjustment of characteristic curve	x	x
Input of characteristic curve		x
Freely-programmable LCD		x
Diagnostic functions		x

Diagnostic functions for SITRANS P300 with PROFIBUS PA and FOUNDATION Fieldbus

- Event counter
- Min/max pointer
- Maintenance timer
- Simulation functions
- Zero correction display
- Limit transmitter
- Saturation alarm

Function (continued)Physical units available for the display

Physical variable	Physical units
Pressure (can also be preset in the factory)	Mpa, kPa, Pa, bar, mbar, torr, atm, psi, g/cm ² , kg/cm ² , mmH ₂ O, mmH ₂ O (4 °C), in H ₂ O, in H ₂ O (4 °C), ftH ₂ O (20 °C), mmHg, inHg
Level (height data)	m, cm, mm, ft, in, yd
Mass	g, kg, t, lb, Ston, Lton, oz
Volume	m ³ , dm ³ , hl, yd ³ , ft ³ , in ³ , US gallon, Imp. gallon, bushel, barrel, barrel liquid
Volume flow	m ³ /s, m ³ /min, m ³ /h, m ³ /d, l/s, l/min, l/h, l/d, Ml/d, ft ³ /s, ft ³ /min, ft ³ /h, ft ³ /d, US gallon/s, US gallon/min, US gallon/h, US gallon/d, bbl/s, bbl/min, bbl/h, bbl/d
Mass flow	g/s, g/min, g/h, g/d, kg/s, kg/min, kg/h, kg/d, t/s, t/min, t/h, t/d, lb/s, lb/min, lb/h, lb/d, STon/s, STon/min, STon/h, STon/d, LTon/s, LTon/min, LTon/h, LTon/d
Temperature	K, °C, °F, °R
Other	%

Hygiene version

In the case of the SITRANS P300 with 7MF812.-... flush-mounted diaphragm, selected connections comply with the requirements of the EHEDG or 3A. You can find further details in the order form. Please note in particular that the seal materials used must comply with the requirements of 3A. Similarly, the filling liquids used must be FDA-compliant.

Pressure measurement

Pressure transmitters

for food, pharmaceuticals and biotechnology / SITRANS P300

Selection and ordering data

		Article No.
SITRANS P300 pressure transmitters for gauge pressure and absolute pressure, single chamber enclosure, nameplate inscription in English		
4 ... 20 mA / HART		7MF8023-
PROFIBUS PA (PA)		7MF8024-
FOUNDATION Fieldbus (FF)		7MF8025-
		● ● ● ● ● - ● ● ● ●
Click the article number for online configuration in the PIA Life Cycle Portal.		
Measuring cell filling	Measuring cell cleaning	
Silicone oil	Normal	1
Inert liquid	Cleanliness level 2 according to DIN 25410	3
Measuring span (min. ... max.)		
8.3 ... 250 mbar (0.12 ... 3.63 psi)		A
0.01 ... 1 bar (0.15 ... 14.5 psi)		B
0.04 ... 4 bar (0.58 ... 58 psi)		C
0.16 ... 16 bar (2.32 ... 232 psi)		D
0.63 ... 63 bar (9.14 ... 914 psi)		E
1.6 ... 160 bar (23.2 ... 2320 psi)		F
4 ... 400 bar (58 ... 5802 psi)		G
8.34 ... 250 mbar a (0.13 ... 3.63 psi a)		Q
43.34 ... 1300 mbar a (0.63 ... 18.86 psi a)		S
0.17 ... 5 bar a (2.43 ... 72.5 psi a)		T
1 ... 30 bar a (14.6 ... 435 psi a)		U
Material of wetted parts		
Seal diaphragm	Measuring cell	
Stainless steel	Stainless steel	A
Hastelloy	Stainless steel	B
Hastelloy	Hastelloy	C
Version for diaphragm seal in combination with "internal thread 1/2-14 NPT" process connection (recommended version) ^{1) 2) 3) 4) 5)}		Y 1
Process connection		
Connection shank G1/2B according to EN 837-1		0
Internal thread 1/2-14 NPT		1
Oval flange with process connection out of stainless steel (oval flange has no internal thread) ⁶⁾		
• Fastening thread 7/16 20 UNF according to EN 61518		2
• Fastening thread M10 according to DIN 19213		3
• Mounting thread M12 according to DIN 19213		4
External thread M20 × 1.5		5
External thread 1/2-14 NPT		6
Material of non-wetted parts		
Stainless steel, deep-drawn and electrolytically polished		4
Version		
Standard version		1
Explosion protection		
None		A
With ATEX, type of protection:		
"Intrinsic safety (Ex ia)"		B
Zone 20/21/22 ⁷⁾		C
Ex nA/nL (Zone 2) ⁸⁾		E
With FM "Intrinsic safety" (cFM _{US})		M
Electrical connection/cable entry		
Screw gland M20×1.5 (polyamide) ⁹⁾		A
Screw gland M20×1.5 (metal)		B
Screw gland M20×1.5 (stainless steel)		C
Device plug M12 (stainless steel, without cable socket)		G
1/2-14 NPT gland threading metal ¹⁰⁾		H
1/2-14 NPT gland threading stainless steel ¹⁰⁾		J
Display		
Without local display, with buttons, closed lid		1
With local display and buttons, closed lid ¹¹⁾		2

Selection and ordering data (continued)

	Article No.
SITRANS P300 pressure transmitters for gauge pressure and absolute pressure, single chamber enclosure, nameplate inscription in English	
4 ... 20 mA / HART	7MF8023-
PROFIBUS PA (PA)	7MF8024-
FOUNDATION Fieldbus (FF)	7MF8025-
	● ● ● ● ● - ● ● ● ● ●
With local display and buttons, lid with polycarbonate pane (setting for HART devices: mA, for PROFIBUS PA and FOUNDATION Fieldbus devices: Pressure units ¹¹⁾)	4
With local display and buttons (setting acc. to specifications, order code "Y21" or "Y22" required), lid with polycarbonate pane ¹¹⁾)	5
With local display and buttons, lid with glass pane (setting for HART devices: mA, for PROFIBUS and FOUNDATION Fieldbus devices: Pressure units ¹¹⁾)	6
With local display and buttons (setting acc. to specifications, order code "Y21" or "Y22" required), lid with glass pane ¹¹⁾)	7

Note:

See section "Supplementary components" for supply units. A quick-start guide is included in the scope of delivery of the device.

- 1) If the quality inspection certificate (factory calibration) according to IEC 60770-2 is to be ordered for transmitters with mounted diaphragm seals, it is recommended that this certificate be ordered exclusively for the remote seals. Here, the measuring accuracy of the entire combination is certified.
- 2) If Inspection Certificate 3.1. is to be ordered for transmitters with mounted diaphragm seals, this certificate must also be ordered with the respective remote seals.
- 3) The diaphragm seal is to be specified with a separate article number and must be included with the transmitter article number, for example 7MF802-..Y..-.... and 7MF0810-.....-0...
- 4) The standard measuring cell filling for configurations with remote seals (Y) is silicone oil.
- 5) Remote seal for direct mounting only available in combination with process connection 1/2-14 NPT.
- 6) M10 fastening thread: Max. measuring span 160 bar (2320 psi) fastening thread 7/16-20 UNF and M12: Max. measuring span 400 bar (5802 psi)
- 7) Can only be ordered together with electrical connection option A.
- 8) Can only be ordered together with electrical connection option B, C or G.
- 9) Only together with HART electronics.
- 10) Without cable gland.
- 11) Local display cannot be rotated.

	Article No.
SITRANS P300 pressure transmitters for gauge pressure and absolute pressure with flush mounted membrane, single chamber enclosure, nameplate inscription in English	
4 ... 20 mA / HART	7MF8123-
PROFIBUS PA (PA)	7MF8124-
FOUNDATION Fieldbus (FF)	7MF8125-
	● ● ● ● ● - ● ● ● ● ●
Click the article number for online configuration in the PIA Life Cycle Portal.	
Measuring cell filling	Measuring cell cleaning
Silicone oil	Normal
Inert liquid	
Food grade oil	
• Neobee oil	Normal
Measuring span (min. ... max.)	
0.01 ... 1 bar (0.15 ... 14.5 psi)	B
0.04 ... 4 bar (0.58 ... 58 psi)	C
0.16 ... 16 bar (2.32 ... 232 psi)	D
0.63 ... 63 bar (9.14 ... 914 psi)	E
43.34 ... 1300 mbar a (0.63 ... 18.86 psi a) ¹¹⁾	S
0.17 ... 5 bar a (2.43 ... 72.5 psi a) ¹¹⁾	T
1 ... 30 bar a (14.6 ... 435 psi a) ¹¹⁾	U
Material of wetted parts	
Seal diaphragm	Measuring cell
Stainless steel	Stainless steel
Hastelloy ²⁾	Stainless steel
Process connection	
Flange version with order code M.., N.., R.. or Q.. (see "Options")	7
Material of non-wetted parts	
Stainless steel, deep-drawn and electrolytically polished	4
Version	
Standard version	1
Explosion protection	
None	A
With ATEX, type of protection:	

Pressure measurement

Pressure transmitters

for food, pharmaceuticals and biotechnology / SITRANS P300

Selection and ordering data (continued)

	Article No.
SITRANS P300 pressure transmitters for gauge pressure and absolute pressure with flush mounted membrane, single chamber enclosure, nameplate inscription in English	
4 ... 20 mA / HART	7MF8123-
PROFIBUS PA (PA)	7MF8124-
FOUNDATION Fieldbus (FF)	7MF8125-
	● ● ● ● ● - ● ● ● ●
"Intrinsic safety (Ex ia)"	
Zone 20/21/22 ³⁾	
Ex nA/nL (Zone 2) ⁴⁾	
With FM "Intrinsic safety" (cFM _{US})	
Electrical connection/cable entry	
Screw gland M20×1.5 (polyamide) ⁵⁾	
Screw gland M20×1.5 (metal)	
Screw gland M20×1.5 (stainless steel)	
Device plug M12 (stainless steel, without cable socket)	
Screw gland ½-14 NPT threading metal ⁶⁾	
½-14 NPT gland threading stainless steel ⁶⁾	
Display	
Without local display, with buttons, closed lid	
With local display and buttons, closed lid ⁷⁾	
With local display and buttons, lid with polycarbonate pane (setting for HART devices: mA, for PROFIBUS PA and FOUNDATION Fieldbus devices: Pressure units ⁷⁾)	
With local display and buttons (setting acc. to specifications, order code "Y21" or "Y22" required), lid with polycarbonate pane ⁷⁾	
With local display and buttons, lid with glass pane (setting for HART devices: mA, for PROFIBUS and FOUNDATION Fieldbus devices: pressure units ⁷⁾)	
With local display and buttons (setting acc. to specifications, order code "Y21" or "Y22" required), lid with glass pane ⁷⁾	
	B C E M A B C G H J 1 2 4 5 6 7

Note:

See section "Supplementary components" for supply units. A quick-start guide is included in the scope of delivery of the device.

- 1) Not with temperature decoupler P00, not for process connections R01, R02, R04, R10 and R11 and can only be ordered together with silicone oil.
- 2) Only available for flanges with option M.., N.. and Q...
- 3) Can only be ordered together with electrical connection option A.
- 4) Can only be ordered together with electrical connection option B, C or G.
- 5) Only together with HART electronics.
- 6) Without cable gland.
- 7) Local display cannot be rotated.

Options	Order code	Communication
Add "-Z" to article number and specify order code.		
Pressure transmitter with mounting bracket (2 brackets, 4 nuts, 4 U washers, 1 angle) Completely of stainless steel, for wall and pipe mounting	A02	HART / PQ / FF
Cable socket for M12 device plug, stainless steel	A51	HART / PQ / FF
Nameplate inscription (in place of English)		HART / PQ / FF
• German	B10	HART / PQ / FF
• French	B12	HART / PQ / FF
• Spanish	B13	HART / PQ / FF
• Italian	B14	HART / PQ / FF
English nameplate Pressure units in inH ₂ O or psi	B21	HART / PQ / FF
Quality inspection certificate (5-point characteristic curve test) according to IEC 62828-2 ¹⁾	C11	HART / PQ / FF
Inspection certificate according to EN 10204-3.1 ²⁾	C12	HART / PQ / FF
Factory certificate according to EN 10204-2.2	C14	HART / PQ / FF
IP65/IP68 degree of protection, only for M20×1.5 and ½-14 NPT	D12	HART / PQ / FF
IP6k9k degree of protection, only for M20×1.5	D46	HART / PQ / FF
CRN Approval Canada (Canadian Registration Number)	E22	HART / PQ / FF
Export approval Korea	E11	HART / PQ / FF

Selection and ordering data (continued)

Options	Order code	Communication
Add "-Z" to article number and specify order code.		
Explosion protection Ex ia according to EAC Ex (Russia)	E80	HART / PQ / FF
Ex approval Ex ia/ib NEPSI	E55	HART / PQ / FF
Only for SITRANS P300 with flush-mounted diaphragm (7MF81...-...)		
Flange according to EN 1092-1 Form B1		
DN 25, PN 40 ³⁾	M11	HART / PQ / FF
DN 40, PN 40	M13	HART / PQ / FF
DN 40, PN 100	M23	HART / PQ / FF
DN 50, PN 16	M04	HART / PQ / FF
DN 50, PN 40	M14	HART / PQ / FF
DN 80, PN 16	M06	HART / PQ / FF
DN 80, PN 40	M16	HART / PQ / FF
Flange according to ASME B16.5		
1", Class 150 ³⁾	M40	HART / PQ / FF
1½", Class 150	M41	HART / PQ / FF
2", Class 150	M42	HART / PQ / FF
3", Class 150	M43	HART / PQ / FF
4", Class 150	M44	HART / PQ / FF
1½", Class 300	M46	HART / PQ / FF
2", Class 300	M47	HART / PQ / FF
3", Class 300	M48	HART / PQ / FF
4", Class 300	M49	HART / PQ / FF
Threaded connection according to DIN 3852-2 Form A, thread according to ISO 228		
G ¾" A, flush mounted ⁴⁾	R01	HART / PQ / FF
G 1" A, flush mounted ⁴⁾	R02	HART / PQ / FF
G 2" A, flush mounted	R04	HART / PQ / FF
Tank connection⁵⁾ Seal not included in scope of delivery		
TG 52/50, PN 40	R10	HART / PQ / FF
TG 52/150, PN 40	R11	HART / PQ / FF
Sanitary process connection according to DIN 11851 (dairy connection with slotted union nut)		
DN 50, PN 25	N04	HART / PQ / FF
DN 80, PN 25	N06	HART / PQ / FF
Tri-Clamp connection according to DIN 32676/ ISO 2852 3A compliant ⁶⁾		
DN 50/2", PN 16	N14	HART / PQ / FF
DN 65/2.5", PN 10	N15	HART / PQ / FF
Clamp 2" ISO 2852, PN 16	N22	HART / PQ / FF
Clamp 3" ISO 2852, PN 10	N23	HART / PQ / FF
Varivent connection 3A and EHEDG compliant ⁶⁾		
Type N = 68 for Varivent enclosure DN 40 ... 125 and 1½" ... 6", PN 40	N28	HART / PQ / FF
Temperature decoupler up to 200 °C⁷⁾ For version with flush-mounted diaphragm		
P00	P00	HART / PQ / FF
Sanitary process connection according to DRD		
DN 50, PN 40	M32	HART / PQ / FF
SMS screwed connector		
2"	M73	HART / PQ / FF
2½"	M74	HART / PQ / FF
3"	M75	HART / PQ / FF
Sanitary process screw connection according to NEUMO BioConnect screw connection, 3A and EHEDG compliant⁶⁾		
DN 50, PN 16	Q05	HART / PQ / FF
DN 65, PN 16	Q06	HART / PQ / FF

Pressure measurement

Pressure transmitters

for food, pharmaceuticals and biotechnology / SITRANS P300

Selection and ordering data (continued)

Options	Order code	Communication
Add "-Z" to article number and specify order code.		
DN 80, PN 16	Q07	HART / PQ / FF
DN 100, PN 16	Q08	HART / PQ / FF
DN 2", PN 16	Q13	HART / PQ / FF
DN 2½", PN 16	Q14	HART / PQ / FF
DN 3", PN 16	Q15	HART / PQ / FF
DN 4", PN 16	Q16	HART / PQ / FF
Sanitary process flange connection according to NEUMO Connect S		
DN 2", PN 16	Q72	HART / PQ / FF
Aseptic screwed connector according to DIN 11864-1 Form A 3A compliant⁵⁾		
DN 50, PN 25	N33	HART / PQ / FF
DN 65, PN 25	N34	HART / PQ / FF
DN 80, PN 25	N35	HART / PQ / FF
DN 100, PN 25	N36	HART / PQ / FF
Aseptic flange with notch according to DIN 11864-2 Form A 3A compliant⁵⁾		
DN 50, PN 16	N43	HART / PQ / FF
DN 65, PN 16	N44	HART / PQ / FF
DN 80, PN 16	N45	HART / PQ / FF
DN 100, PN 16	N46	HART / PQ / FF
Aseptic flange with groove according to DIN 11864-2 Form A 3A compliant⁵⁾		
DN 50, PN 16	N43 + P11	HART / PQ / FF
DN 65, PN 16	N44 + P11	HART / PQ / FF
DN 80, PN 16	N45 + P11	HART / PQ / FF
DN 100, PN 16	N46 + P11	HART / PQ / FF
Aseptic clamp with groove according to DIN 11864-3 Form A 3A compliant⁵⁾		
DN 50, PN 25	N53	HART / PQ / FF
DN 65, PN 25	N54	HART / PQ / FF
DN 80, PN 16	N55	HART / PQ / FF
DN 100, PN 16	N56	HART / PQ / FF
Additional information Add "-Z" to article number, specify order code and plain text.		
Measuring range to be set Specify in plain text (max. 5 digits): Y01: ... to ... mbar, bar, kPa, MPa, psi	Y01	HART / PQ ⁸⁾
Tag plate made of stainless steel and entry in the device variable (measuring point description) Max. 16 characters; specify in plain text: Y15:	Y15	HART / PQ / FF
Measuring point text (entry in device variable) Max. 27 characters; specify in plain text: Y16:	Y16	HART / PQ / FF
Entry of HART TAG Max. 8 characters; specify in plain text: Y17:	Y17	HART
Setting of the local display in pressure units Specify in plain text (default setting: bar): Y21: mbar, bar, kPa, MPa, psi, ...	Y21	HART / PQ / FF
Note The following pressure units can be selected: bar, mbar, mm H ₂ O ¹⁰⁾ , inH ₂ O ¹⁰⁾ , ftH ₂ O ¹⁰⁾ , mmHG, inHG, psi, Pa, kPa, MPa, g/cm ² , kg/cm ² , Torr, ATM or %		
Setting of the local display in non-pressure units⁹⁾ Specify in plain text: Y22: to l, m ³ , m, USg, ... (Specification of measuring range in pressure units "Y01" is essential, unit with max. 5 characters)	Y22 + Y01	HART

Selection and ordering data (continued)

Options	Order code	Communication
Add "-Z" to article number and specify order code.		
Preset bus address, possible range 1 ... 126 Specify in plain text: Y25:	Y25	PQ / FF

Note:

Factory-mounting of valve manifolds, see Accessories. Only Y01, Y15, Y16, Y17, Y21, Y22 and Y25 are possible as factory preset.

- 1) If the quality inspection certificate (factory calibration) according to IEC 60770-2 is to be ordered for transmitters with mounted diaphragm seals, it is recommended that this certificate be ordered exclusively for the remote seals. Here, the measuring accuracy of the entire combination is certified.
- 2) If Inspection Certificate 3.1. is to be ordered for transmitters with mounted diaphragm seals, this certificate must also be ordered with the respective remote seals.
- 3) Special Viton seal included in scope of delivery (FKM; temperature range -20 ... +200 °C (-4 ... +392 °F))
- 4) Cannot be combined with order code P00. Can only be ordered together with silicon oil measuring cell filling.
- 5) Weld-in sockets can be ordered under Accessories.
- 6) 3A compliance ensured only when 3A compliant sealing rings are used.
- 7) Conformity according to 3A and EHEDG. The maximum permissible medium temperatures depend on the respective measuring cell fillings (see process conditions).
- 8) Measuring accuracies for PROFIBUS PA transmitters with option Y01 are calculated in the same way as for HART devices.
- 9) Preset value can only be change via SIMATIC PDM
- 10) 20 °C reference temperature.

Spare parts/accessories	Article number
Mounting bracket and fastening parts kit Made of stainless steel	7MF8997-1AA
Lid without inspection window Gasket not included	7MF8997-1BA
Lid with glass inspection window Gasket not included	7MF8997-1BD
NBR enclosure sealing	7MF8997-1BG
Measuring point label Unlabeled	7MF8997-1CA
Cable gland	
• Metal	7MF8997-1EA
• Plastic (blue)	7MF8997-1EB
Weldable sockets for PMC connection	
• PMC style Standard: Thread 1 1/2"	7MF4997-2HA
• PMC style Minibolt: Flush-mounted 1"	7MF4997-2HB
Gaskets for PMC connection (Packing unit: 5 units)	
• PTFE seal for PMC Style Standard: Thread 1 1/2"	7MF4997-2HC
• Gasket made of Viton for PMC Style Minibolt: Flush-mounted 1"	7MF4997-2HD
Weldable sockets for TG 52/50 and TG 52/150 connection	
• TG 52/50 connection	7MF4997-2HE
• TG 52/150 connection	7MF4997-2HF
Seals for TG 52/50 and TG 52/150 made of silicone	7MF4997-2HG
Seals for flange connection with flush-mounted diaphragm Material FKM (Viton); temperature range:-20 ... +200 °C (-4 ... +392 °F), 10 units	
• DN 25, PN 40 (M11)	7MF4997-2HH
• 1", Class 150 (M40)	7MF4997-2HK

Pressure measurement

Pressure transmitters

for food, pharmaceuticals and biotechnology / SITRANS P300

Selection and ordering data (continued)

Documentation	Article number
The entire documentation is available for download free of charge in various languages at: http://www.siemens.com/processinstrumentation/documentation	
Compact operating instructions • English, German, Spanish, French, Italian, Dutch	A5E03434657
HART modem	
With USB interface	7MF4997-1DB

Note:

See section "Supplementary components" for supply units.

Ordering example	
Item line:	7MF8023-1DB24-1AB7-Z
B line	A02 + Y01 + Y21
C-line	Y01: 1 ... 10 bar (14.5 ... 145 psi)
C-line	Y21: bar (psi)

Technical specifications

SITRANS P300 for gauge and absolute pressure

Gauge pressure input

Measured variable
 Measuring span (infinitely adjustable) or nominal measuring range, max. permissible operating pressure (in accordance with 2014/68/EU Pressure Equipment Directive) and max. permissible test pressure (pursuant to DIN 16086)
 (for oxygen measurement, max. 100 bar/10 MPa/1450 psi and 60 °C (140 °F) ambient temperature/medium temperature)

Gauge pressure

HART

Measuring span

8.3 ... 250 mbar
 0.83 ... 25 kPa
 0.12 ... 3.6 psi
 0.01 ... 1 bar
 1 ... 100 kPa
 0.15 ... 14.5 psi
 0.04 ... 4 bar
 4 ... 400 kPa
 0.58 ... 58 psi
 0.16 ... 16 bar
 16 ... 1600 kPa
 2.3 ... 232 psi
 0.63 ... 63 bar
 63 ... 6300 kPa
 9.1 ... 914 psi
 1.6 ... 160 bar
 0.16 ... 16 MPa
 23 ... 2321 psi
 4 ... 400 bar
 0.4 ... 40 MPa
 58 ... 5802 psi

PROFIBUS PA/FOUNDATION Fieldbus

Nominal measuring range

250 mbar
 25 kPa
 3.6 psi
 1 bar
 100 kPa
 14.5 psi
 4 bar
 400 kPa
 58 psi
 16 bar
 1600 kPa
 232 psi
 63 bar
 6300 kPa
 914 psi
 160 bar
 16 MPa
 2321 psi
 400 bar
 40 MPa
 5802 psi

Max. permissible operating pressure MAWP (PS)

4 bar
 400 kPa
 58 psi
 4 bar
 400 kPa
 58 psi
 7 bar
 0.7 Mpa
 102 psi
 21 bar
 2.1 MPa
 305 psi
 67 bar
 6.7 MPa
 972 psi
 167 bar
 16.7 MPa
 2422 psi
 400 bar
 40 MPa
 5802 psi

Max. permissible test pressure

6 bar
 600 kPa
 87 psi
 6 bar
 600 kPa
 87 psi
 10 bar
 1 MPa
 145 psi
 32 bar
 3.2 MPa
 464 psi
 100 bar
 10 MPa
 1450 psi
 250 bar
 25 MPa
 3626 psi
 600 bar
 60 MPa
 8702 psi

Lower measuring limit

For 250 mbar/25 kPa/3.6 psi measuring cells, the lower measuring limit is 750 mbar a/75 kPa a/10.8 psi a. The measuring cell is vacuum-resistant up to 30 mbar a/3 kPa a/0.44 psi a.

- Measuring cell with silicone oil filling
- Measuring cell with inert filling liquid

30 mbar a/3 kPa a/0.44 psi a

30 mbar a/3 kPa a/0.44 psi a

Upper measuring limit

100% of the max. measuring span (for oxygen measurement max. 100 bar/10 MPa/1450 psi and 60 °C (140 °F) ambient temperature/medium temperature)

Absolute pressure input

Measured variable
 Measuring span (continuously adjustable) or nominal measuring range, max. permissible operating pressure (in accordance with 2014/68/EU Pressure Equipment Directive) and max. permissible test pressure (pursuant to DIN 16086)

Absolute pressure

HART

Measuring span

8.34 ... 250 mbar a
 0.83 ... 25 kPa a
 3.35 ... 100 inH₂O a
 0.13 ... 3.63 psi a
 43.34 ... 1300 mbar a
 4.33 ... 130 kPa a
 17.42 ... 522.4 inH₂O a
 0.63 ... 18.86 psi a
 0.17 ... 5 bar a
 17 ... 500 kPa a
 2.43 ... 72.5 psi a
 1 ... 30 bar a
 0.1 ... 3 MPa a
 14.6 ... 435 psi a

PROFIBUS PA/FOUNDATION Fieldbus

Nominal measuring range

250 mbar a
 25 kPa a
 100 inH₂O a
 1300 mbar a
 130 kPa a
 525 inH₂O a
 5000 mbar a
 500 kPa a
 72.5 psi a
 30 bar a
 3 MPa a
 435 psi a

Max. permissible operating pressure MAWP (PS)

1.5 bar a
 150 kPa a
 21.8 psi a
 2.6 bar a
 260 kPa a
 37.7 psi a
 10 bar a
 1 MPa a
 145 psi a
 45 bar a
 4.5 MPa a
 653 psi a

Max. permissible test pressure

6 bar a
 600 kPa a
 87 psi a
 10 bar a
 1 MPa a
 145 psi a
 30 bar a
 3 MPa a
 435 psi a
 100 bar a
 10 MPa a
 1450 psi a

Lower measuring limit

- Measuring cell with silicone oil filling
 - Measuring cell with inert liquid
- For medium temperature -20 °C < ϑ ≤ +60 °C
 (-4 °F < ϑ ≤ +140 °F)

0 mbar a/3 kPa a/0.44 psi a

30 mbar a/0 kPa a/0 psi a

Pressure measurement

Pressure transmitters

for food, pharmaceuticals and biotechnology / SITRANS P300

Technical specifications (continued)

SITRANS P300 for gauge and absolute pressure			
- For medium temperature $60\text{ °C} < \vartheta \leq +100\text{ °C}$ (max. 85 °C for measuring cell 30 bar) ($140\text{ °F} < \vartheta \leq +212\text{ °F}$ (max. 185 °F for measuring cell 435 psi))			
		$30\text{ mbar a} + 20\text{ mbar a} \cdot (\vartheta - 60\text{ °C})/\text{°C}$ $3\text{ kPa a} + 2\text{ kPa a} \cdot (\vartheta - 60\text{ °C})/\text{°C}$ $0.44\text{ psi a} + 0.29\text{ psi a} \cdot (\vartheta - 140\text{ °F})/\text{°F}$	
Upper measuring limit	100% of the max. measuring span (for oxygen measurement max. 100 bar/10 MPa/1450 psi and 60 °C (140 °F) ambient temperature/medium temperature)		
Lower range value	Between the measuring limits (continuously adjustable)		
Input of gauge pressure with front-flush diaphragm			
Measured variable	Gauge pressure, flush-mounted		
Measuring span (continuously adjustable) or nominal measuring range, max. permissible operating pressure and max. permissible test pressure	HART	PROFIBUS PA/FOUNDATION Fieldbus	
	Measuring span	Nominal measuring range	Max. permissible operating pressure MAWP (PS)
			Max. permissible test pressure
	0.01 ... 1 bar	1 bar	4 bar
	1 ... 100 kPa	100 kPa	400 kPa
	0.15 ... 14.5 psi	14.5 psi	58 psi
	0.04 ... 4 bar	4 bar	7 bar
	4 ... 400 kPa	400 kPa	0.7 MPa
	0.58 ... 58 psi	58 psi	102 psi
	0.16 ... 16 bar	16 bar	21 bar
	16 ... 1600 kPa	1600 kPa	2.1 MPa
	2.3 ... 232 psi	232 psi	305 psi
	0.63 ... 63 bar	63 bar	67 bar
	63 ... 6300 kPa	6300 kPa	6.7 MPa
	9.1 ... 914 psi	914 psi	972 psi
			1450 psi
Lower measuring limit	100 mbar a (1.45 psi a)		
• Measuring cell with silicone oil	100 mbar a/10 kPa a/1.45 psi a		
• Measuring cell with inert liquid	100 mbar a/10 kPa a/1.45 psi a		
• Measuring cell with neobee	100 mbar a/10 kPa a/1.45 psi a		
Upper measuring limit	100% of max. measuring span		
Input of absolute pressure, with flush-mounted diaphragm			
Measured variable	Absolute pressure, flush-mounted		
Measuring span (continuously adjustable) or nominal measuring range and max. permissible test pressure	HART	PROFIBUS PA/FOUNDATION Fieldbus	
	Measuring span	Nominal measuring range	Max. permissible operating pressure MAWP (PS)
			Max. permissible test pressure
	43 ... 1300 mbar a	1300 mbar a	2.6 bar a
	4.3 ... 130 kPa a	130 kPa a	260 kPa a
	17 ... 525 inH ₂ O a	525 inH ₂ O a	37.7 psi a
	160 ... 5000 mbar a	5000 mbar a	10 bar a
	16 ... 500 kPa a	500 kPa a	1 MPa a
	2.32 ... 72.5 psi a	72.5 psi a	145 psi a
	1 ... 30 bar a	30 bar a	45 bar a
	0.1 ... 3 MPa a	3 MPa a	4.5 MPa a
	14.5 ... 435 psi a	435 psi a	653 psi a
			1450 psi a
Lower measuring limit	Depending on the process connection, the measuring span may differ from these values		
	0 mbar a/0 kPa a/0 psi a		
Upper measuring limit	100% of max. measuring span		
Output			
Output signal	HART	PROFIBUS PA/FOUNDATION Fieldbus	
Physical bus	4 ... 20 mA	Digital PROFIBUS PA signal	
Protection against polarity reversal	-	IEC 61158-2	
	Protected against short-circuit and polarity reversal. Each connection against the other with max. supply voltage.	Protected against short-circuit and polarity reversal. Each connection against the other with max. supply voltage.	
Electrical damping (step width 0.1 s)	Set to 2 s (0 ... 100 s)	Set to 2 s (0 ... 100 s)	

Technical specifications (continued)

SITRANS P300 for gauge and absolute pressure	
Measuring accuracy for gauge pressure	According to IEC 62828-1
Reference conditions	<ul style="list-style-type: none"> • Rising characteristic curve • Lower range value 0 bar • Seal diaphragm stainless steel • Measuring cell with silicone oil • Room temperature 25 °C (77 °F)
Measuring span ratio (spread, Turn-Down)	r = maximum measuring span/set measuring span or nominal measuring range
<u>Measurement deviation at limit setting including hysteresis and reproducibility</u>	
<ul style="list-style-type: none"> • Linear characteristic curve 	
- 250 mbar/25 kPa/3.6 psi	$r \leq 1.25: \leq 0.075\%$ $1.25 < r \leq 30: \leq (0.008 \cdot r + 0.065)\%$
- 1 bar/100 kPa/14.5 psi 4 bar/400 kPa/58 psi 16 bar/1.6 MPa/232 psi 63 bar/6.3 MPa/914 psi 160 bar/16 MPa/2321 psi	$r \leq 5: \leq 0.075\%$ $5 < r \leq 100: \leq (0.005 \cdot r + 0.05)\%$
- 400 bar/40 MPa/5802 psi	$r \leq 3: \leq 0.075\%$ $3 < r \leq 10: \leq (0.0029 \cdot r + 0.071)\%$ $10 < r \leq 100: \leq (0.005 \cdot r + 0.05)\%$
<u>Influence of ambient temperature (in percent per 28 °C (50 °F))</u>	
<ul style="list-style-type: none"> • 250 mbar/25 kPa/3.6 psi 	$\leq (0.16 \cdot r + 0.1)\%$
<ul style="list-style-type: none"> • 1 bar/100 kPa/14.5 psi 4 bar/400 kPa/58 psi 16 bar/1.6 MPa/232 psi 63 bar/6.3 MPa/914 psi 160 bar/16 MPa/2321 psi 400 bar/40 MPa/5802 psi 	$\leq (0.07 \cdot r + 0.08)\%$
<u>Long-term stability (temperature change ± 30 °C (± 54 °F))</u>	
<ul style="list-style-type: none"> • 250 mbar/25 kPa/3.6 psi 	$\leq (0.16 \cdot r)\%$ per year
<ul style="list-style-type: none"> • 1 bar/100 kPa/14.5 psi 4 bar/400 kPa/58 psi 	$\leq (0.25 \cdot r)\%$ in 5 years
<ul style="list-style-type: none"> • 16 bar/1.6 MPa/232 psi 63 bar/6.3 MPa/914 psi 160 bar/16 MPa/2321 psi 400 bar/40 MPa/5802 psi 	$\leq (0.125 \cdot r)\%$ in 5 years
Influence of mounting position	≤ 0.05 mbar/0.005 kPa/0.000725 psi per 10° incline (zero offset is possible with position error compensation)
Effect of auxiliary power (in percent per voltage change)	0.005% per 1 V
Measured value resolution for PROFIBUS PA and FOUNDATION Fieldbus	$3 \cdot 10^{-5}$ of nominal measuring range
Measuring accuracy for absolute pressure	According to IEC 62828-1
Reference conditions	<ul style="list-style-type: none"> • Rising characteristic curve • Lower range value 0 bar • Seal diaphragm stainless steel • Silicone oil filling • Room temperature 25 °C (77 °F)
(All error information always refers to the set measuring span)	
Measuring span ratio r (spread, Turn-Down)	r = maximum measuring span/set measuring span or nominal measuring range
<u>Measurement deviation at limit setting including hysteresis and reproducibility</u>	
<ul style="list-style-type: none"> • Linear characteristic curve 	
- $r \leq 10$	$\leq 0.1\%$
- $10 < r \leq 30$	$\leq 0.2\%$
<u>Influence of ambient temperature (in percent per 28 °C (50 °F))</u>	
<ul style="list-style-type: none"> • 250 mbar a/25 kPa a/3.6 psi a 	$\leq (0.15 \cdot r + 0.1)\%$

Pressure measurement

Pressure transmitters

for food, pharmaceuticals and biotechnology / SITRANS P300

Technical specifications (continued)

SITRANS P300 for gauge and absolute pressure		
<ul style="list-style-type: none"> 1300 mbar a/130 kPa a/18.8 psi a 5 bar a/500 kPa a/72.5 psi a 30 bar a/3000 kPa a/435 psi a 	$\leq (0.08 \cdot r + 0.16)\%$	
Long-term stability (temperature change $\pm 30\text{ °C}$ ($\pm 54\text{ °F}$))	$\leq (0.25 \cdot r)\%$ in 5 years	
Effect of mounting position (in pressure per change of angle)	$\leq 0.05\text{ mbar}/0.005\text{ kPa}/0.000725\text{ psi}$ per 10° incline (zero-point correction is possible with position error compensation)	
Effect of auxiliary power (in percent per voltage change)	0.005% per 1 V	
Measured value resolution for PROFIBUS PA and FOUNDATION Fieldbus	$3 \cdot 10^{-5}$ of nominal measuring range	
Measuring accuracy for gauge and absolute pressure, with flush-mounted diaphragm		
Reference conditions (All error information always refers to the set measuring span)	According to IEC 62828-1	
	<ul style="list-style-type: none"> Rising characteristic curve Lower range value 0 bar Seal diaphragm stainless steel Silicone oil filling Room temperature 25 °C (77 °F) 	
Measuring span ratio r (spread, Turn-Down)	$r =$ maximum measuring span/set measuring span or nominal measuring range	
<u>Measurement deviation at limit setting including hysteresis and reproducibility</u>		
<ul style="list-style-type: none"> Linear characteristic curve 	Gauge pressure with flush-mounted diaphragm	Absolute pressure with flush-mounted diaphragm
- $r \leq 5$	$\leq 0.075\%$	-
- $5 < r \leq 100$	$\leq (0.005 \cdot r + 0.05)\%$	-
- $r \leq 10$	-	$\leq 0.2\%$
- $10 < r \leq 30$	-	$\leq 0.4\%$
Influence of ambient temperature (in percent per 28 °C (50 °F))	$\leq (0.08 \cdot r + 0.16)\%$	$\leq (0.16 \cdot r + 0.24)\%$
<u>Influence of the medium temperature (in pressure per temperature unit)</u>		
<ul style="list-style-type: none"> Temperature difference between medium temperature and ambient temperature 	3 mbar/0.3 kPa/0.04 psi per 10 K	
Long-term stability (temperature change $\pm 30\text{ °C}$ ($\pm 54\text{ °F}$))	$\leq (0.25 \cdot r)\%$ in 5 years	
Effect of mounting position (in pressure per change of angle)	0.4 mbar/0.04 kPa/0.006 per 10° incline (zero offset is possible with position error compensation)	
Effect of auxiliary power (in percent per voltage change)	0.005% per 1 V	
Measured value resolution for PROFIBUS PA and FOUNDATION Fieldbus	$3 \cdot 10^{-5}$ of nominal measuring range	

Operating conditions

Installation conditions

Ambient temperature	Observe the temperature class in hazardous areas.
<ul style="list-style-type: none"> Measuring cell with silicone oil 	-40 ... +85 °C (-40 ... +185 °F)
<ul style="list-style-type: none"> Measuring cell with Neobee oil (FDA-compliant, with flush-mounted diaphragm) 	-10 ... +85 °C (14 ... 185 °F)
<ul style="list-style-type: none"> Measuring cell with inert liquid 	-40 ... +85 °C (-40 ... +185 °F)
<ul style="list-style-type: none"> Display readable 	-30 ... +85 °C (-22 ... +185 °F)
<ul style="list-style-type: none"> Storage temperature 	-50 ... +85 °C (-58 ... +185 °F) - For Neobee: -20 ... +85 °C (-4 ... +185 °F) - For high-temperature oil: -10 ... +85 °C (14 ... +185 °F)
<ul style="list-style-type: none"> Climatic class 	
- Condensation	Relative humidity 0 ... 100% Condensation permissible, suitable for use in the tropics

Technical specifications (continued)

Operating conditions	
Degree of protection	
• According to IEC 60529	IP65, IP68
• According to NEMA 250	Type 4X, enclosure cleaning, resistant to lyes, steam to 150 °C (302 °F)
Electromagnetic compatibility	
• Emitted interference and interference immunity	According to IEC 61326 and NAMUR NE 21
Process conditions	
Medium temperature	The max. medium temperature of the flush-mounted process connections is to be taken into account in accordance with the relevant connection standards (e.g. DIN 32676, DIN 11851, etc.).
• Measuring cell with silicone oil	-40 ... +100 °C (-40 ... +212 °F)
• Measuring cell with silicone oil (with flush-mounted diaphragm)	-40 ... +150 °C (-40 ... +302 °F)
• Measuring cell with Neobee oil (FDA-compliant, with flush-mounted diaphragm)	-10 ... +150 °C (14 ... 302 °F)
• Measuring cell with silicone oil, with temperature decoupler (only for gauge pressure version with flush-mounted diaphragm)	-40 ... +200 °C (-40 ... +392 °F)
• Measuring cell with Neobee oil, with temperature decoupler (only for gauge pressure version with flush-mounted diaphragm)	-10 ... +200 °C (14 ... 392 °F)
• Measuring cell with inert liquid	-20 ... +100 °C (-4 ... +212 °F)
Structural design (standard version)	
Weight (without options)	Approx. 800 g (1.8 lbs)
Enclosure material	Stainless steel, mat. no. 1.4301/304
Material of wetted parts	
• Connection shank	Stainless steel, mat. no. 1.4404/316L or Hastelloy C276, mat. no. 2.4819
• Oval flange	Stainless steel, mat. no. 1.4404/316L
• Seal diaphragm	Stainless steel, mat. no. 1.4404/316L or Hastelloy C276, mat. no. 2.4819
• Measuring cell filling	<ul style="list-style-type: none"> • Silicone oil • Inert filling liquid
Process connection	<ul style="list-style-type: none"> • G½B according to EN 837-1 • Internal thread ½-14 NPT • Oval flange PN 160 (MAWP 2320 psi) with fastening thread: <ul style="list-style-type: none"> - 7/16-20 UNF according to with IEC 61518/EN 61518 - M10 according to DIN 19213
Structural design (version with flush-mounted diaphragm)	
Weight (without options)	Approx. 1 ... 13 kg (2.2 ... 29 lbs)
Enclosure material	Stainless steel, mat. no. 1.4301/304
Material of wetted parts	
• Process connection	Stainless steel, mat. no. 1.4404/316L
• Seal diaphragm	Stainless steel, mat. no. 1.4404/316L

Pressure measurement

Pressure transmitters

for food, pharmaceuticals and biotechnology / SITRANS P300

Technical specifications (continued)

Operating conditions			
Measuring cell filling	<ul style="list-style-type: none"> Silicone oil Inert filling liquid Food grade oil (Neobee oil) 		
Process connection	<ul style="list-style-type: none"> Flanges according to EN and ASME F&B and pharmaceutical flanges 		
Surface quality touched-by-media	R_a values $\leq 0.8 \mu\text{m}$ (32 $\mu\text{-inch}$)/welds $R_a \leq 1.6 \mu\text{m}$ (64 $\mu\text{-inch}$) (Process connections according to 3A; R_a values $\leq 0.8 \mu\text{m}$ (32 μinch)/welds $R_a \leq 0.8 \mu\text{m}$ (32 μinch))		
Auxiliary power U_H	<table border="0"> <tr> <td>HART</td> <td>PROFIBUS PA/FOUNDATION Fieldbus</td> </tr> </table>	HART	PROFIBUS PA/FOUNDATION Fieldbus
HART	PROFIBUS PA/FOUNDATION Fieldbus		
Terminal voltage on transmitter	<table border="0"> <tr> <td>10.5 ... 42 V DC 10.5 ... 30 V DC for intrinsically safe operation</td> <td>-</td> </tr> </table>	10.5 ... 42 V DC 10.5 ... 30 V DC for intrinsically safe operation	-
10.5 ... 42 V DC 10.5 ... 30 V DC for intrinsically safe operation	-		
Auxiliary power	- Bus-powered		
Separate supply voltage	- Not necessary		
Bus voltage			
<ul style="list-style-type: none"> Without Ex 	- 9 ... 32 V		
<ul style="list-style-type: none"> With intrinsically safe operation 	- 9 ... 24 V		
Current consumption			
<ul style="list-style-type: none"> Max. basic current 	- 12.5 mA		
<ul style="list-style-type: none"> Starting current \leq basic current 	- Yes		
<ul style="list-style-type: none"> Max. fault current in the event of an error 	- 15.5 mA		
Fault disconnection electronics (FDE) available	- Yes		
Certificates and approvals	<table border="0"> <tr> <td>HART</td> <td>PROFIBUS PA/FOUNDATION Fieldbus</td> </tr> </table>	HART	PROFIBUS PA/FOUNDATION Fieldbus
HART	PROFIBUS PA/FOUNDATION Fieldbus		
Classification according to pressure equipment directive (PED 2014/68/EU)	For gasses of fluid group 1 and liquids of fluid group 1; complies with requirements of Article 4, Paragraph 3 (sound engineering practice)		
Water, waste water	Available soon		
Explosion protection			
Intrinsic safety "i"	PTB 05 ATEX 2048		
<ul style="list-style-type: none"> Marking 	II1/2 G Ex ia IIC/IB T4/T5/T6 Ga/Gb		
<ul style="list-style-type: none"> Permissible ambient temperature 			
- Temperature class T4	-40 ... +85 °C (-40 ... +185 °F)		
- Temperature class T5	-40 ... +70 °C (-40 ... +158 °F)		
- Temperature class T6	-40 ... +60 °C (-40 ... +140 °F)		
<ul style="list-style-type: none"> Connection 	<table border="0"> <tr> <td>To certified intrinsically safe circuits with peak values: $U_i = 30 \text{ V}$, $I_i = 100 \text{ mA}$, $P_i = 750 \text{ mW}$, $R_i = 300 \Omega$</td> <td>To certified intrinsically safe circuits with peak values: FISCO supply unit: $U_i = 17.5 \text{ V}$, $I_i = 380 \text{ mA}$, $P_i = 5.32 \text{ W}$ Linear barrier: $U_i = 24 \text{ V}$, $I_i = 250 \text{ mA}$, $P_i = 1.2 \text{ W}$</td> </tr> </table>	To certified intrinsically safe circuits with peak values: $U_i = 30 \text{ V}$, $I_i = 100 \text{ mA}$, $P_i = 750 \text{ mW}$, $R_i = 300 \Omega$	To certified intrinsically safe circuits with peak values: FISCO supply unit: $U_i = 17.5 \text{ V}$, $I_i = 380 \text{ mA}$, $P_i = 5.32 \text{ W}$ Linear barrier: $U_i = 24 \text{ V}$, $I_i = 250 \text{ mA}$, $P_i = 1.2 \text{ W}$
To certified intrinsically safe circuits with peak values: $U_i = 30 \text{ V}$, $I_i = 100 \text{ mA}$, $P_i = 750 \text{ mW}$, $R_i = 300 \Omega$	To certified intrinsically safe circuits with peak values: FISCO supply unit: $U_i = 17.5 \text{ V}$, $I_i = 380 \text{ mA}$, $P_i = 5.32 \text{ W}$ Linear barrier: $U_i = 24 \text{ V}$, $I_i = 250 \text{ mA}$, $P_i = 1.2 \text{ W}$		
<ul style="list-style-type: none"> Effective internal capacitance 	$C_i = 6 \text{ nF}$		
<ul style="list-style-type: none"> Effective internal inductance 	$L_i = 0.4 \text{ mH}$		
Explosion protection to FM for USA and Canada (cFMus)			
<ul style="list-style-type: none"> Identification (DIP) or (IS); (NI) 	Certificate of Compliance 3025099 CL I, DIV 1, GP ABCD T4 ... T6; CL II, DIV 1, GP EFG; CL III; CL I, ZN 0/1 AEx ia IIC T4 ... T6 CL I, DIV 2, GP ABCD T4 ... T6; CL II, DIV 2, GP FG; CL III		

Technical specifications (continued)

Operating conditions		
• Identification (DIP) or (IS)	Certificate of Compliance 3025099C CL I, DIV 1, GP ABCD T4 ... T6; CL II, DIV 1, GP EFG; CL III; Ex ia IIC 4 ... T6 CL I, DIV 2, GP ABCD T4 ... T6; CL II, DIV 2, GP FG; CL III	
Dust explosion protection for Zone 20/21/22	PTB 05 ATEX 2048	
• Marking	II 1 D Ex ia IIC T ₂₀₀ 122 °C Da II 1/2 D Ex ia IIC T ₂₀₀ 122 °C Da/Db II 2 D Ex ib IIC T ₂₀₀ 122 °C Db	
• Permissible ambient temperature		
- Temperature class T4	-40 ... +85 °C (-40 ... +185 °F) (for mineral glass window -20 ... +85 °C (-4 ... +185 °F))	
- Temperature class T5	-40 ... +70 °C (-40 ... +158 °F) (for mineral glass window -20 ... +70 °C (-4 ... +158 °F))	
- Temperature class T6	-40 ... +60 °C (-40 ... +140 °F) (for mineral glass window -20 ... +60 °C (-4 ... +140 °F))	
• Connection	To certified intrinsically safe circuits with peak values: U _i = 30 V, I _i = 100 mA, P _i = 750 mW	To certified intrinsically safe circuits with peak values: U _i = 24 V, I _i = 380 mA, P _i = 5.-32 W
• Effective internal capacitance	C _i = 6 nF	C _i = 5 nF
• Effective internal inductance	L _i = 0.4 µH	L _i = 10 µH
Type of protection Ex nA/nL/ic (Zone 2)	PTB 05 ATEX 2048	
• Marking	II 3 G Ex ic IIC T6 ... T4 Gc II 3 G Ex ec IIC T6 ... T4 Gc II 3 G Ex ic IIC T6 ... T4 Gc	
• Permissible ambient temperature		
- Temperature class T4	-40 ... +85 °C (-40 ... +185 °F) (only for mineral glass window -20 ... +85 °C (-4 ... +185 °F))	
- Temperature class T5	-40 ... +70 °C (-40 ... +158 °F) (only for mineral glass window -20 ... +70 °C (-4 ... +158 °F))	
- Temperature class T6	-40 ... +60 °C (-40 ... +140 °F) (only for mineral glass window -20 ... +60 °C (-4 ... +140 °F))	
• Ex nA/nL connection	To certified intrinsically safe circuits with peak values: U _m = 45 V	To certified intrinsically safe circuits with peak values: U _m = 32 V
• Ex ic connection	To certified intrinsically safe circuits with peak values: U _i = 45 V	To certified intrinsically safe circuits with peak values: U _i = 32 V
• Effective internal capacitance	C _i = 6 nF	C _i = 5 nF
• Effective internal inductance	L _i = 0.4 mH	L _i = 20 µH

Communication

Communication	
HART	
HART	230 ... 1100 Ω
Protocol	HART version 5.x
Software for computer	SIMATIC PDM
PROFIBUS PA	
Simultaneous communication with master class 2 (max.)	4
The address can be set using	Configuration tool or local operation (standard setting Address 126)
Cyclic data usage	
• Output byte	5 (one measured value) or 10 (two measured values)
• Input byte	0, 1 or 2 (totalizer mode and reset function for dosing)
Internal preprocessing	
Device profile	PROFIBUS PA Profile for Process Control Devices Version 3.0, Class B
Function blocks	2

Pressure measurement

Pressure transmitters

for food, pharmaceuticals and biotechnology / SITRANS P300

Technical specifications (continued)

Communication	
• Analog input	
- Adaptation to user-specific process variable	Yes, linearly rising or falling characteristic curve
- Electrical damping adjustable	0 ... 100 s
- Simulation function	Output/input
- Failure mode	Parameterizable (last good value, substitute value, incorrect value)
- Limit monitoring	Yes, one upper and lower warning limit and one alarm limit respectively
• Register (totalizer)	
- Failure mode	Can be reset, preset, optional direction of counting, simulation function of register output
- Limit monitoring	Parameterizable (summation with last good value, continuous summation, summation with incorrect value)
• Physical block	
Transducer blocks	1
• Pressure transducer block	
- Can be calibrated by applying two pressures	2
- Monitoring of sensor limits	Yes
- Specification of a vessel characteristic curve with	Yes
- Simulation function for measured pressure value and sensor temperature	Max. 30 nodes
	Constant value or by means of parameterizable ramp function
FOUNDATION Fieldbus	
Function blocks	3 function blocks analog input, 1 function block PID
• Analog input	
- Adaptation to user-specific process variable	Yes, linearly rising or falling characteristic curve
- Electrical damping adjustable	0 ... 100 s
- Simulation function	Output/input (can be locked within the device with a bridge)
- Failure mode	Parameterizable (last good value, substitute value, incorrect value)
- Limit monitoring	Yes, one upper and lower warning limit and one alarm limit respectively
- Square-rooted characteristic curve for flow measurement	Yes
• PID	
	Standard-FOUNDATION Fieldbus function block
• Physical block	
Transducer blocks	1 resource block
• Pressure transducer block	
- Can be calibrated by applying two pressures	1 transducer block Pressure with calibration, 1 transducer block LCD
- Monitoring of sensor limits	Yes
- Simulation function: Measured pressure value, sensor temperature and electronics temperature	Yes
	Constant value or by means of parameterizable ramp function

Dimensional drawings

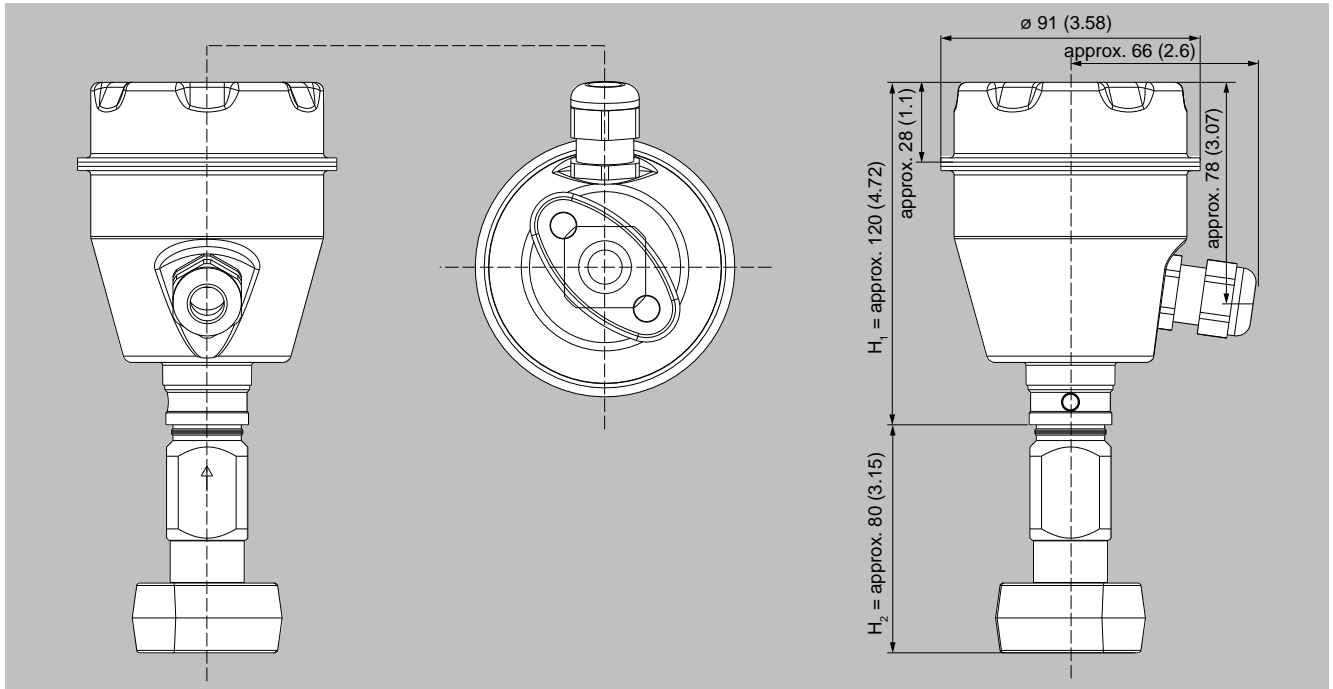

SITRANS P300, with oval flange, dimensions in mm (inch)

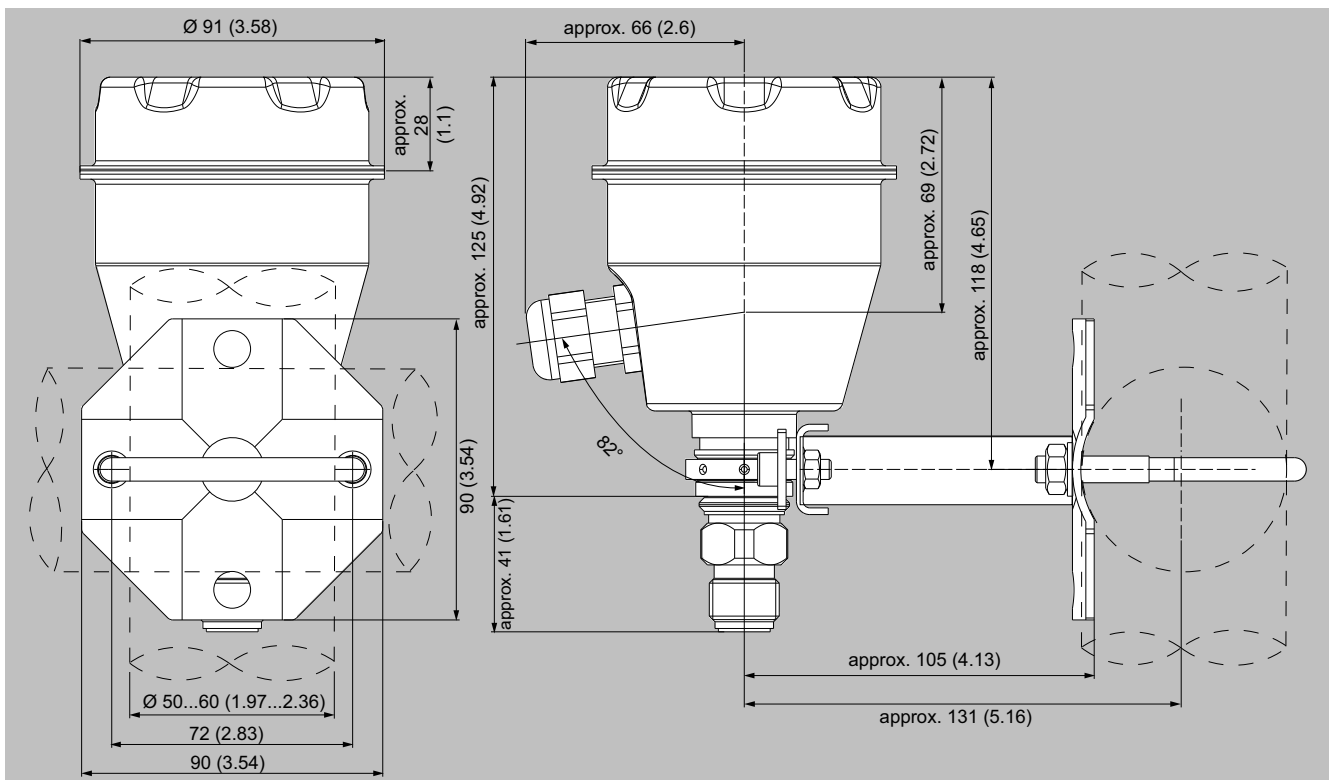

SITRANS P300, process connection M20 × 1.5, with built-in mounting bracket, dimensions in mm (inch)

Pressure measurement

Pressure transmitters

for food, pharmaceuticals and biotechnology / SITRANS P300

Dimensional drawings (continued)

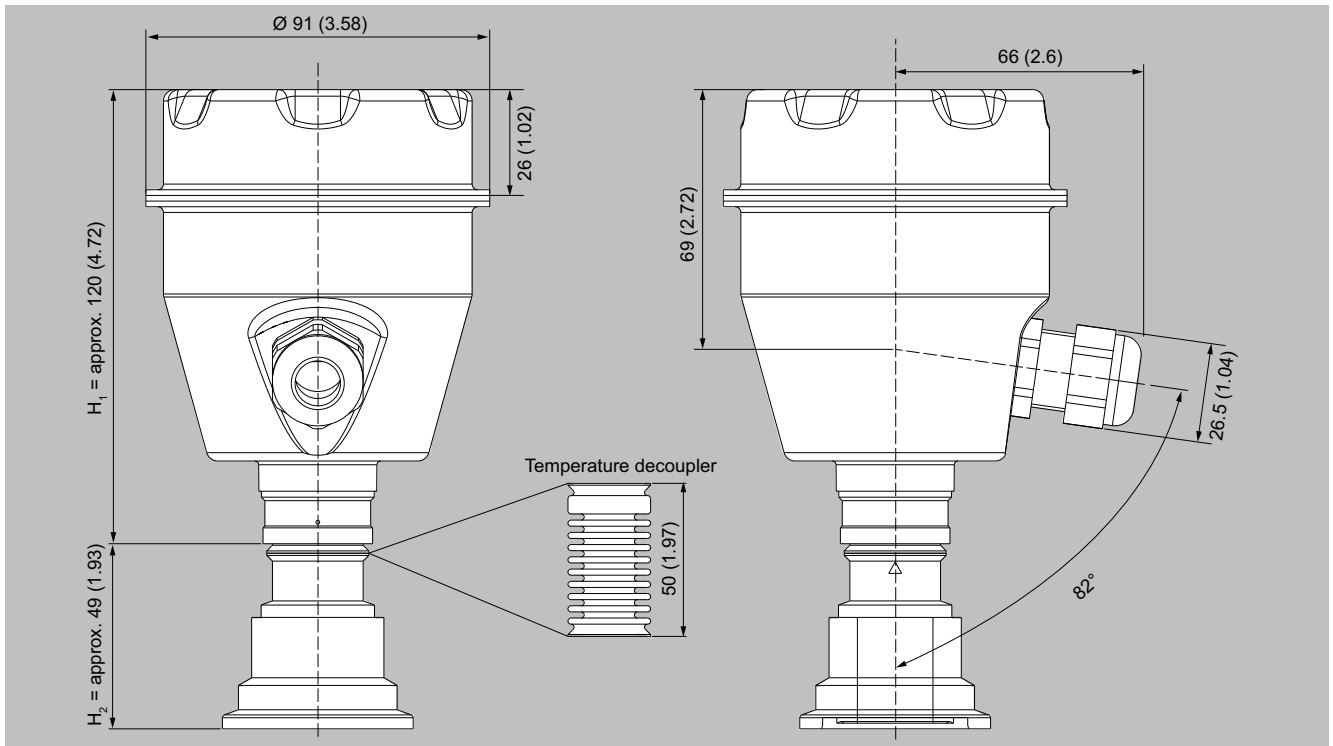

SITRANS P300, flush-mounted, dimensions in mm (inch)

The figure shows a SITRANS P300 with an example flange. In this drawing the height is subdivided into H_1 and H_2 .

H_1 = Height of the SITRANS P300 up to a defined cross-section

H_2 = Height of the flange up to this defined cross-section

Only the height H_2 is indicated in the dimensions of the flanges.

Flanges according to EN and ASME

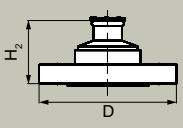
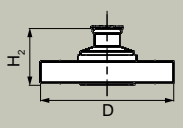
Flange	Order code	DN	PN	ØD	H_2
EN 1092-1 	M11	25	40	115 mm (4.5 inches)	Approx. 52 mm (2 inches)
	M13	40	40	150 mm (5.9 inches)	
	M23	40	100	170 mm (6.7 inches)	
	M04	50	16	165 mm (6.5 inches)	
	M14	50	40	165 mm (6.5 inches)	
	M06	80	16	200 mm (7.9 inches)	
	M16	80	40	200 mm (7.9 inches)	
ASME B16.5 	M40	1 inch	150	110 mm (4.3 inches)	Approx. 52 mm (2 inches)
	M41	1½ inches	150	130 mm (5.1 inches)	
	M42	2 inches	150	150 mm (5.9 inches)	
	M43	3 inches	150	190 mm (7.5 inches)	
	M44	4 inches	150	230 mm (9.1 inches)	
	M45	1 inch	300	125 mm (4.9 inches)	
	M46	1½ inches	300	155 mm (6.1 inches)	
	M47	2 inches	300	165 mm (6.5 inches)	
	M48	3 inches	300	210 mm (8.1 inches)	
	M49	4 inches	300	255 mm (10.0 inches)	

Dimensional drawings (continued)

NuG and pharmaceutical connections

Connections according to DIN

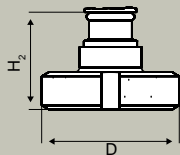
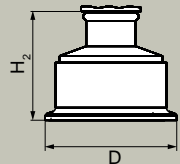
Connection	Order code	DN	PN	ØD	H ₂
DIN 11851 (dairy connection with slotted union nut) 	N04	50	25	92 mm (3.6 inches)	Approx. 52 mm (2 inches)
	N06	80	25	127 mm (5.0 inches)	
Tri-Clamp acc. to DIN 32676 	N14	50	16	64 mm (2.5 inches)	Approx. 52 mm (2 inches)
	N15	65	10	91 mm (3.6 inches)	

Other connections

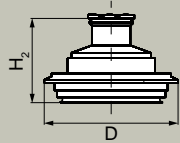
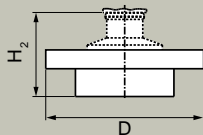
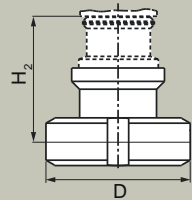
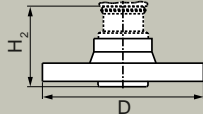
Connection	Order code	DN	PN	ØD	H ₂
Varivent connection 	N28	40 ... 125	40	84 mm (3.3 inches)	Approx. 52 mm (2 inches)
Sanitary process connection according to DRD 	M32	50	40	105 mm (4.1 inches)	Approx. 52 mm (2 inches)
Sanitary process screw connection according to NEUMO BioConnect 	Q05	50	16	82 mm (3.2 inches)	Approx. 52 mm (2 inches)
	Q06	65	16	105 mm (4.1 inches)	
	Q07	80	16	115 mm (4.5 inches)	
	Q08	100	16	145 mm (5.7 inches)	
	Q13	2 inches	16	82 mm (3.2 inches)	
	Q14	2½ inches	16	105 mm (4.1 inches)	
	Q15	3 inches	16	105 mm (4.1 inches)	
Q16	4 inches	16	145 mm (5.7 inches)		
Sanitary process connection according to NEUMO BioConnect S flange connection 	Q72	2 inches	16	125 mm (4.9 inches)	Approx. 52 mm (2 inches)

Pressure measurement

Pressure transmitters

for food, pharmaceuticals and biotechnology / SITRANS P300

Dimensional drawings (continued)

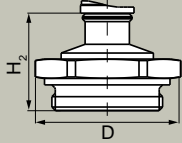
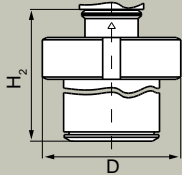
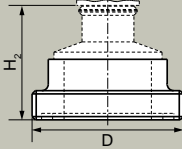
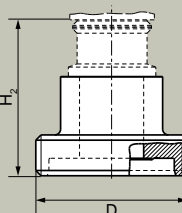
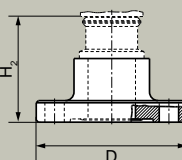
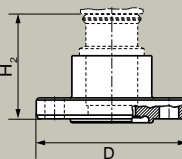
Connection	Order code	DN	PN	ØD	H ₂
Threaded connection G$\frac{3}{4}$ inch, G1 inch and G2 inch according to DIN 3852-2 Form A 	R01 R02 R04	$\frac{3}{4}$ inch 1 inch 2 inches	60 60 60	37 mm (1.5 inches) 48 mm (1.9 inches) 78 mm (3.1 inches)	Approx. 45 mm (1.8 inches) Approx. 47 mm (1.9 inches) Approx. 52 mm (2 inches)
Tank connection TG 52/50 and TG 52/150 	R10 R11	25 25	40 40	63 mm (2.5 inches) 63 mm (2.5 inches)	Approx. 63 mm (2.5 inches) Approx. 170 mm (6.7 inches)
SMS screwed connector 	M73 M74 M75	2 inches 2½ inches 3 inches	25 25 25	70 x 1/6 mm 85 x 1/6 mm 98 x 1/6 mm	Approx. 52 mm (2.1 inches)
Aseptic screwed connector according to DIN 11864-1 Form A 	N33 N34 N35 N36	50 65 80 100	25 25 25 25	78 x 1/6 inch 95 x 1/6 inch 110 x ¼ inch 130 x ¼ inch	Approx. 52 mm (2.1 inches)
Aseptic flange with notch according to DIN 11864-2 Form A 	N43 N44 N45 N46	50 65 80 100	16 16 16 16	94 113 133 159	Approx. 52 mm (2.1 inches)
Aseptic flange with groove according to DIN 11864-2 Form A 	N43 + P11 N44 + P11 N45 + P11 N46 + P11	50 65 80 100	16 16 16 16	94 113 133 159	Approx. 52 mm (2.1 inches)

Dimensional drawings (continued)

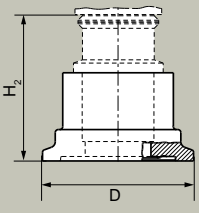
Connection	Order code	DN	PN	ØD	H ₂
Aseptic clamp with groove according to DIN 11864-3 Form A 	N53	50	25	77.5	Approx. 52 mm (2.1 inches)
	N54	65	25	91	
	N55	80	16	106	
	N56	100	16	130	

Pressure measurement

Pressure transmitters

for food, pharmaceuticals and biotechnology / Factory mounting of valve manifolds on SITRANS P300

Overview

The SITRANS P300 transmitter for gauge and absolute pressure can be delivered factory-fitted with the following valve manifold 7MF9011-4EA and 7MF9011-4FA.

Design

The 7MF9011-4EA valve manifolds are sealed with PTFE sealings between the transmitter and the valve manifold as standard. Soft iron, stainless steel and copper sealings are also available for sealing purposes if preferred.

The 7MF9011-4FA valve manifolds are sealed with PTFE sealing tape between the transmitter and the valve manifold.

The complete unit is checked for leaks under pressure after assembly (air pressure 6 bar (87 psi)) and certified with a factory certificate according to EN 10204 - 2.2.

All valve manifolds should preferably be secured with the corresponding mounting brackets. The transmitters are mounted on the valve manifold and not on the unit itself.

If you order a mounting bracket when choosing the option "Factory-mounting of valve manifolds", you will receive a mounting bracket for the valve manifold instead of a bracket for mounting the transmitter.

If you order an inspection certificate 3.1 to EN 10204 after choosing the option "Factory-mounting of valve manifolds", a separate certificate is provided for the transmitter and for the valve manifold.

Selection and ordering data

Valve manifolds

7MF9011-4FA valve manifold on gauge and absolute pressure transmitters



Add -Z to the article number of the transmitter and specify order codes

SITRANS P300

7MF802-...1-...

With process connection internal thread 1/2-14 NPT, in-sealed with PTFE sealing tape
Delivery including high-pressure test certified by factory certificate according to EN 10204-2.2

Additional versions:

Delivery includes mounting bracket and stainless steel mounting clips (instead of the mounting bracket supplied with the transmitter)

Inspection certificate according to EN 10204-3.1 for transmitter and mounted valve manifold

Order code

T03

A02

C12

7MF9011-4EA valve manifold on gauge and absolute pressure transmitters



Add -Z to the article number of the transmitter and specify order codes

SITRANS P300

7MF802-...0-...

With process connection shank G1/2 A according to EN 837-1, gasket made of PTFE between valve manifold and transmitter

Alternative gasket material:

- Soft iron
- Stainless steel, mat. no. 14571
- Copper

Delivery including high-pressure test certified by factory certificate according to EN 10204-2.2

Additional versions:

Delivery includes mounting bracket and stainless steel mounting clips (instead of the mounting bracket supplied with the transmitter)

Inspection certificate according to EN 10204- 3.1 for transmitters and mounted valve manifold

Order code

T02

A70

A71

A72

A02

C12

Dimensional drawings

Valve manifolds mounted on SITRANS P300



7MF9011-4EA valve manifold with mounted gauge pressure and absolute pressure transmitters

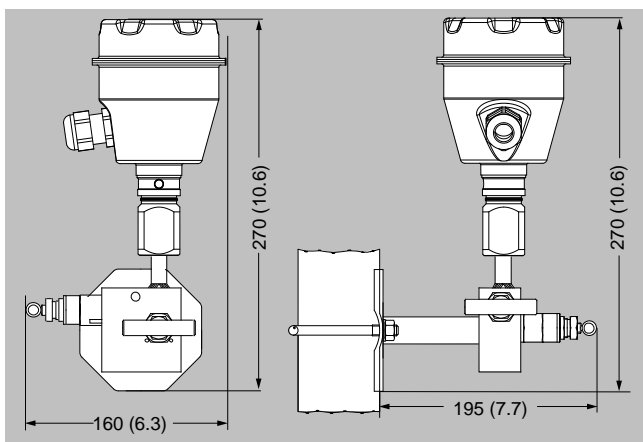

7MF9011-4EA valve manifold with mounted gauge pressure and absolute pressure transmitters, dimensions in mm (inch)

Dimensional drawings (continued)



7MF9011-4FA valve manifold with mounted gauge pressure and absolute pressure transmitters

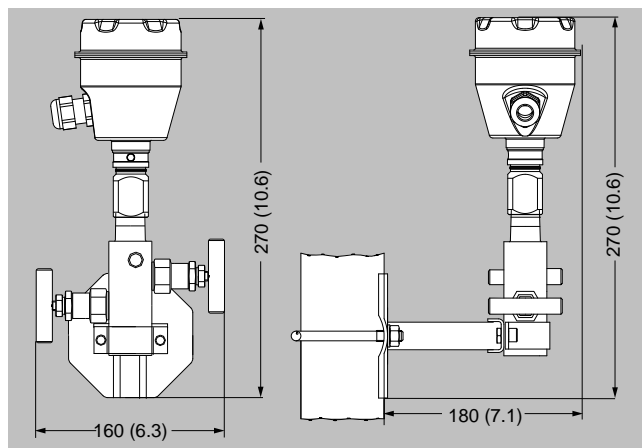

7MF9011-4FA valve manifold with mounted gauge pressure and absolute pressure transmitters, dimensions in mm (inch)