

Level Measurement

Continuous level measurement – Capacitance transmitters

SITRANS LC300

Overview

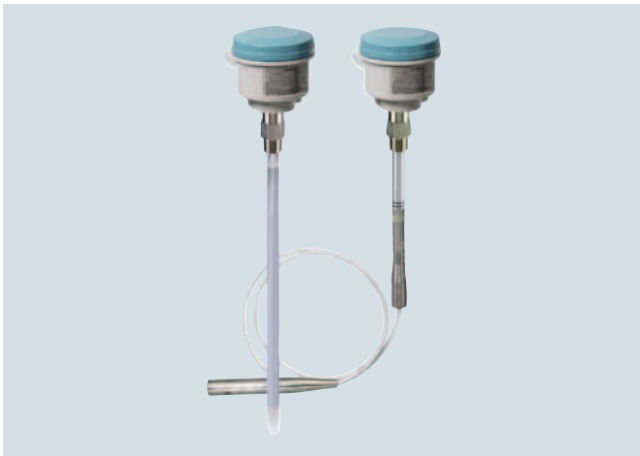

SITRANS LC300 is an inverse frequency shift capacitance continuous level transmitter for liquids and solids applications. It is ideal for standard industrial applications in chemical, hydrocarbon processing, food and beverage, water, wastewater, and mining, aggregate, and cement industries.

Benefits

- Patented Active-Shield technology so measurement is unaffected by material buildup in active shield section
- Highly accurate and reliable PFA-lined probes
- Integrated local LCD display
- 2-wire (4 to 20 mA) current loop design
- Current signaling according to NAMUR NE 43
- Push-button calibration and programming
- Stilling well (ground tube) version for low dielectric media and non-metallic vessels

Application

SITRANS LC300 is a 2-wire level measurement instrument combining a sophisticated, yet easy-to-adjust microprocessor with field-proven probes. It is available in four versions: rod, rod with stilling well, cable with PFA insulation, and cable without PFA insulation.

Materials with low or high dielectric properties are accurately measured and patented Active-Shield technology helps in ignoring the effects of buildup or condensation near vessel nozzle.

- Key Applications: Conductive and non-conductive media including: liquids and solids in standard industrial processes, bulk solids applications involving dust, and chemical processes involving vapor

Configuration

Installation

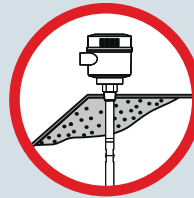

Build up of material in active shield area does not affect switch operation.

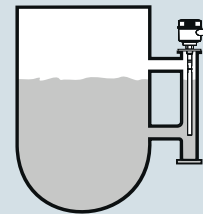

Mounting on a bypass

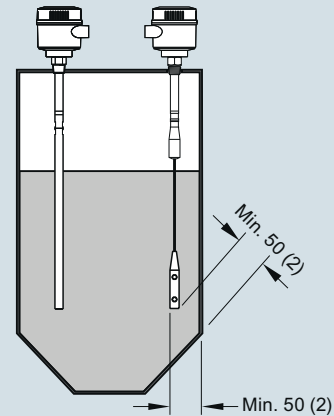

Install probe at least 50 (2) from tank wall.
Note angle of repose and adjust accordingly.

SITRANS LC300 installation, dimensions in mm (inch)

Level Measurement

Continuous level measurement – Capacitance transmitters

SITRANS LC300

Technical specifications

Input	
Measuring range	1.66 ... 3 300 pF
Span	Min. 3.3 pF
Output	
Loop current	Continuous signal 4 ... 20 mA/20 ... 4 mA according to NAMUR 43
Accuracy (transmitter)	
Temperature stability	0.25 % of actual capacitance value
Non-linearity and repeatability	< 0.4 % of full scale and actual measurement value
Accuracy	Deviation < 0.5 % of actual measurement value
Rated operating conditions¹⁾	
Ambient conditions	
• Ambient temperature	-40 ... +85 °C (-40 ... +185 °F) ²⁾
• Installation category	I
• Pollution degree	4
• Ingress protection	Type 4/NEMA 4/IP65 (optional IP68)
Installation conditions	
• Location	Indoor/outdoor
Process pressure	-1 ... +35 bar g (-14.6 ... +511 psi g)
Process temperature	-40 ... +200 °C (-40 ... +392 °F) ³⁾
Min. dielectric constant ϵ_r	1.5
Design	
Material	
• Enclosure	Aluminum, epoxy-coated
Probe diameter	
• Rod version	19 mm (0.75 inch) with PFA jacket
• Cable version	9 mm (0.35 inch) with PFA jacket, 6 mm (0.24 inch) without PFA jacket
Active shield length	
• Rod version	Threaded: 120 mm (4.72 inch) Flanged: 100 mm (3.94 inch)
• Cable version	Threaded: 125 mm (4.92 inch) Flanged: 105 mm (4.13 inch)
Process connection of probe	
• Threaded rod mounting	$\frac{3}{4}$ ", 1", 1 $\frac{1}{4}$ ", 1 $\frac{1}{2}$ " NPT [(Taper), ANSI/ASME B1.20.1] R $\frac{3}{4}$ ", 1", 1 $\frac{1}{2}$ " [(BSPT), EN 10226/PT (JIS-T), JIS B 0203] G $\frac{3}{4}$ ", 1", 1 $\frac{1}{2}$ " [(BSPP), EN ISO 228-1/PF (JIS-P), JIS B 0202]
• Threaded cable mounting	1 $\frac{1}{2}$ " NPT [(Taper), ANSI/ASME B1.20.1] R 1 $\frac{1}{2}$ " [(BSPT), EN 10226/PT (JIS-T), JIS B 0203] G 1 $\frac{1}{2}$ " [(BSPP), EN ISO 228-1/PF (JIS-P), JIS B 0202]
• Flange mounting	1 ... 4" ASME, DN 25 ... 100
Enclosure cable inlet	2 x $\frac{1}{2}$ " NPT or 2 x M20x1.5
Power supply	
	12 ... 30 V DC any polarity, 2-wire current loop circuit
User Interface	
Display	Local LCD, 4 digit, each 0 ... 9 and limited alpha characters

Safety	
Measurement current signaling	According to NAMUR NE 43, signal 3.8 ... 20.5 mA, fault \leq 3.6 or \geq 21 mA (22 mA)
Certificates and approvals	
General	CE, CSA _{US/C} , FM, C-TICK
Dust Ignition Proof (Intrinsically Safe probe circuit)	
• Canada/USA	FM/CSA: Class II, Div. 1, Groups E, F, G Class III T4 ATEX 1/2 D T100 °C
• Europe	
Flame Proof (Intrinsically Safe probe circuit)	
• Europe	ATEX II 1/2 G EEx d [ia] IIC T6...T1 ATEX II 1/2 D T100 °C
Explosion Proof (Intrinsically Safe probe circuit)	
• Canada/USA	Class I, Div. 1, Groups A, B, C, D Class II, Div. 1, Groups E, F, G Class III T4
Marine	Bureau Veritas Type Approval ABS Type Approval
Overfill Protection	AIB-Vincotte
Other	Pattern Approval (China)

¹⁾ When operation is in areas classified as hazardous, observe restrictions according to relevant certificate. See also Pressure/Temperature curves on page 4/308.

²⁾ Thermal isolator is used if process connection temperature exceeds 85 °C (185 °F)

³⁾ Not suitable for steam environments

Design: Probe	Rod version	Stilling well version	Cable version
Length	Min. 300 mm (12 inch), max. 5 000 mm (197 inch)	Min. 300 mm (12 inch), max. 5 000 mm (197 inch)	Min. 1 000 mm (40 inch), max. 25 000 mm (984 inch)
Sensor wetted parts	PFA, 316L stainless steel	PFA, 316L stainless steel	316L stainless steel or 316L stainless steel with PFA insulation
O-ring seal material	FKM or FFKM	FKM or FFKM	FKM or FFKM
Thermal isolator	Optional	Optional	Optional
Options	N/A	N/A	Mounting eye for PFA insulated cable version

Level Measurement

Continuous level measurement – Capacitance transmitters

SITRANS LC300

Selection and Ordering data	Article No.	Selection and Ordering data	Article No.
SITRANS LC300, rod version	7ML5670-	SITRANS LC300, rod version	7ML5670-
An inverse frequency shift capacitance continuous level transmitter for liquids and solids applications.	0	An inverse frequency shift capacitance continuous level transmitter for liquids and solids applications.	0
Process connection		Wetted seals	
Threaded, 316L stainless steel		FKM	0
¾" NPT [(Taper), ANSI/ASME B1.20.1]	0 A	FFKM [for process temperatures above -20 °C (-4 °F)]	1
1" NPT [(Taper), ANSI/ASME B1.20.1]	0 B		
1¼" NPT [(Taper), ANSI/ASME B1.20.1]	0 C	Probe material	
1½" NPT [(Taper), ANSI/ASME B1.20.1]	0 D	19 mm (0.75 inch) diameter 316L stainless steel, PFA lined rod	0
R ¾" [(BSPT), EN 10226/PT (JIS-T), JIS B 0203]	1 A		
R 1" [(BSPT), EN 10226/PT (JIS-T), JIS B 0203]	1 B	Approvals	
R 1½" [(BSPT), EN 10226/PT (JIS-T), JIS B 0203]	1 D	General Safety (CSA, FM, CE, C-TICK)	A
G ¾" [(BSPP), EN ISO 228-1/PF (JIS-P), JIS B 0202]	3 A	Dust Ignition Proof With IS Probe CE, C-TICK, ATEX II 1/2 D T100 °C	B
G 1" [(BSPP), EN ISO 228-1/PF (JIS-P), JIS B 0202]	3 B	Flame Proof Enclosure With IS Probe CE, C-TICK, ATEX II 1/2 G EEx d [ia] IIC T6...T1, ATEX II 1/2 D T100 °C	C
G 1½" [(BSPP), EN ISO 228-1/PF (JIS-P), JIS B 0202]	3 D	Dust Ignition Proof With IS Probe CSA/FM Class II, Div. 1, Groups E, F, G CSA/FM Class III T4	D
<u>Welded flange, 316L stainless steel, raised face¹⁾</u>		Explosion Proof Enclosure With IS Probe CSA/FM Class I, Div. 1, Groups A, B, C, D CSA/FM Class II, Div. 1, Groups E, F, G CSA/FM Class III T4	E
1" ASME, 150 lb	5 A		
1" ASME, 300 lb	5 B	Enclosure	
1" ASME, 600 lb	5 C	Aluminum epoxy coated 2 x ½" NPT via adapter - cable inlet, IP65	A
1½" ASME, 150 lb	5 D	Aluminum epoxy coated 2 x M20 x 1.5 cable inlet, IP65	B
1½" ASME, 300 lb	5 E	Aluminum epoxy coated 2 x ½" NPT via adapter - cable inlet, IP68	C
1½" ASME, 600 lb	5 F	Aluminum epoxy coated 2 x M20 x 1.5 cable inlet, IP68	D
2" ASME, 150 lb	5 G		
2" ASME, 300 lb	5 H		
2" ASME, 600 lb	5 J		
3" ASME, 150 lb	5 K		
3" ASME, 300 lb	5 L		
3" ASME, 600 lb	5 M		
4" ASME, 150 lb	5 N		
4" ASME, 300 lb	5 P		
4" ASME, 600 lb	5 Q		
<u>Welded flange, 316L stainless steel, Type A flat faced¹⁾</u>			
DN 25, PN 16	6 A		
DN 25, PN 40	6 B		
DN 40, PN 16	6 C		
DN 40, PN 40	6 D		
DN 50, PN 16	6 E		
DN 50, PN 40	6 F		
DN 80, PN 16	6 G		
DN 80, PN 40	6 H		
DN 100, PN 16	6 J		
DN 100, PN 40	6 K		
Probe Length (from flange face or including process thread)			
<u>Add Order code Y01 and plain text: "Insertion length ... mm"</u>			
300 ... 1 000 mm (11.81 ... 39.37 inch)	A		
1 001 ... 2 000 mm (39.41 ... 78.74 inch)	B		
2 001 ... 3 000 mm (78.78 ... 118.11 inch)	C		
3 001 ... 4 000 mm (118.15 ... 157.48 inch)	D		
4 001 ... 5 000 mm (157.52 ... 196.85 inch)	E		
Thermal isolator			
Without thermal isolator	0		
With thermal isolator [for process connection temperatures over 85 °C (185 °F)]	1		

¹⁾ Flange bolting patterns and facings dimensionally correspond to the applicable ASME B16.5 or EN 1092-1 standard.

Level Measurement

Continuous level measurement – Capacitance transmitters

SITRANS LC300

Selection and Ordering data	Order code
Further designs	
Please add "-Z" to Article No. and specify Order code(s).	
Insertion length, specify in plain text: Y01: ... mm	Y01
Stainless steel tag [69 x 50 mm (2.71 x 1.97 inch)]; Measuring-point number/identification (max. 27 characters) specify in plain text	Y15
Manufacturer's Test Certificate: M to DIN 55350, Part 18 and to ISO 9000	C11
Inspection Certificate Type 3.1 per EN 10204	C12
Operating Instructions	
English	7ML1998-5HE03
French	7ML1998-5HE11
German	7ML1998-5HE33
Spanish	7ML1998-5HE21
Multi-language Quick Start manual	A5E32268590
Note: The Operating Instructions should be ordered as a separate line item on the order.	
This device is shipped with the Siemens Milltronics manual DVD containing the ATEX Quick Start and Operating Instructions library.	
Accessories	
Electronic transmitter kit (includes transmitter and driver)	7ML1830-1KN
SITRANS RD100 Remote display - see Chapter 7	
SITRANS RD200 Remote display - see Chapter 7	
SITRANS RD500 web, datalogging, alarming, ethernet, and modem support for instrumentation - see Chapter 7	7ML5750-1AA00-0

Level Measurement

Continuous level measurement – Capacitance transmitters

SITRANS LC300

Selection and Ordering data	Article No.	Selection and Ordering data	Article No.
SITRANS LC300, stilling well version An inverse frequency shift capacitance continuous level transmitter for liquid applications.	7ML5671- - - - - - 0	SITRANS LC300, stilling well version An inverse frequency shift capacitance continuous level transmitter for liquid applications.	7ML5671- - - - - - 0
Process connection Threaded, 316L stainless steel 1½" NPT [(Taper), ANSI/ASME B1.20.1] R 1½" [(BSPT), EN 10226/PT (JIS-T), JIS B 0203] G 1½" [(BSPP), EN ISO 228-1/PF (JIS-P), JIS B 0202] <u>Welded flange, 316L stainless steel, raised face¹⁾</u> 1½" ASME, 150 lb 1½" ASME, 300 lb 1½" ASME, 600 lb 2" ASME, 150 lb 2" ASME, 300 lb 2" ASME, 600 lb 3" ASME, 150 lb 3" ASME, 300 lb 3" ASME, 600 lb 4" ASME, 150 lb 4" ASME, 300 lb 4" ASME, 600 lb <u>Welded flange, 316L stainless steel, Type A flat faced¹⁾</u> DN 40, PN 16 DN 40, PN 40 DN 50, PN 16 DN 50, PN 40 DN 80, PN 16 DN 80, PN 40 DN 100, PN 16 DN 100, PN 40	0 D 1 D 3 D 5 D 5 E 5 F 5 G 5 H 5 J 5 K 5 L 5 M 5 N 5 P 5 Q 6 C 6 D 6 E 6 F 6 G 6 H 6 J 6 K	Enclosure Aluminum epoxy coated 2 x ½" NPT via adapter - cable inlet, IP65 Aluminum epoxy coated 2 x M20 x 1.5 cable inlet, IP65 Aluminum epoxy coated 2 x ½" NPT via adapter - cable inlet, IP68 Aluminum epoxy coated 2 x M20 x 1.5 cable inlet, IP68	A B C D
Probe Length (from flange face or including process thread) <u>Add Order code Y01 and plain text: "Insertion length ... mm"</u> 300 ... 1 000 mm (11.81 ... 39.37 inch) 1 001 ... 2 000 mm (39.41 ... 78.74 inch) 2 001 ... 3 000 mm (78.78 ... 118.11 inch) 3 001 ... 4 000 mm (118.15 ... 157.48 inch) 4 001 ... 5 000 mm (157.52 ... 196.85 inch)	A B C D E	Operating Instructions English French German Spanish Multi-language Quick Start manual Note: The Operating Instructions should be ordered as a separate line item on the order. This device is shipped with the Siemens Milltronics manual DVD containing the ATEX Quick Start and Operating Instructions library.	Order code Y01 Y15 C11 C12 Article No. 7ML1998-5HE03 7ML1998-5HE11 7ML1998-5HE33 7ML1998-5HE21 7ML1998-5QH81
Thermal isolator Without thermal isolator With thermal isolator [for process connection temperatures over 85 °C (185 °F)]	0 1	Accessories Electronic transmitter kit (includes transmitter and driver) SITRANS RD100 Remote display - see Chapter 7 SITRANS RD200 Remote display - see Chapter 7 SITRANS RD500 web, datalogging, alarming, ethernet, and modem support for instrumentation - see Chapter 7	7ML1830-1KN 7ML5750-1AA00-0
Wetted seals FKM FFKM [for process temperatures above -20 °C (-4 °F)]	0 1		
Probe material 35 mm (1.38 inch) diameter stilling well, with 19 mm (0.75 inch) diameter 316L stainless steel, PFA lined rod with PTFE spacers	1		
Approvals General Safety (CSA, FM, CE, C-TICK) Dust Ignition Proof With IS Probe CE, C-TICK, ATEX II 1/2 D T100 °C Flame Proof Enclosure With IS Probe CE, C-TICK, ATEX II 1/2 G EEx d [ia] IIC T6 ... T1, ATEX II 1/2 D T100 °C Dust Ignition Proof With IS Probe CSA/FM Class II, Div. 1, Groups E, F, G CSA/FM Class III T4 Explosion Proof Enclosure With IS Probe CSA/FM Class I, Div. 1, Groups A, B, C, D CSA/FM Class II, Div. 1, Groups E, F, G CSA/FM Class III T4	A B C D E		

Level Measurement

Continuous level measurement – Capacitance transmitters

SITRANS LC300

Selection and Ordering data

Article No.

SITRANS LC300, cable version

7ML5672-

An inverse frequency shift capacitance continuous level transmitter for non-conductive liquids and solids applications.

Process connection

Threaded, 316L stainless steel

1½" NPT [(Taper), ANSI/ASME B1.20.1]

R 1½" [(BSPT), EN 10226/PT (JIS-T), JIS B 0203]

G 1½" [(BSPP), EN ISO 228-1/PF (JIS-P), JIS B 0202]

Welded flange, 316L stainless steel, raised face¹⁾

1½" ASME, 150 lb

1½" ASME, 300 lb

1½" ASME, 600 lb

2" ASME, 150 lb

2" ASME, 300 lb

2" ASME, 600 lb

3" ASME, 150 lb

3" ASME, 300 lb

3" ASME, 600 lb

4" ASME, 150 lb

4" ASME, 300 lb

4" ASME, 600 lb

Welded flange, 316L stainless steel, Type A flat faced¹⁾

DN 40, PN 16

DN 40, PN 40

DN 50, PN 16

DN 50, PN 40

DN 80, PN 16

DN 80, PN 40

DN 100, PN 16

DN 100, PN 40

Probe Length

(from flange face or including process thread)

Add Order code Y01 and plain text:

"Insertion length ... mm"

1 000 ... 2 000 mm (39.37 ... 78.74 inch)

2 001 ... 4 000 mm (78.78 ... 157.48 inch)

4 001 ... 6 000 mm (157.52 ... 236.22 inch)

6 001 ... 8 000 mm (236.26 ... 314.96 inch)

8 001 ... 10 000 mm (315.00 ... 393.70 inch)

10 001 ... 12 000 mm (393.74 ... 472.44 inch)

12 001 ... 14 000 mm (472.48 ... 551.18 inch)

14 001 ... 16 000 mm (551.22 ... 629.92 inch)²⁾

16 001 ... 18 000 mm (629.96 ... 708.66 inch)²⁾

18 001 ... 20 000 mm (708.70 ... 787.40 inch)²⁾

20 001 ... 22 000 mm (787.44 ... 866.14 inch)²⁾

22 001 ... 24 000 mm (866.18 ... 944.88 inch)²⁾

24 001 ... 25 000 mm (944.92 ... 984.25 inch)²⁾

Thermal isolator

Without thermal isolator

With thermal isolator [for process connection temperatures over 85 °C (185 °F)]

Wetted seals

FKM

FFKM [for process temperatures above -20 °C (-4 °F)]

Probe material

Bare 316L stainless steel cable and 316L stainless steel cable weight, tinned copper crimp, PTFE backing ring, PEEK isolator and PFA lined active shield

Selection and Ordering data

Article No.

SITRANS LC300, cable version

7ML5672-

An inverse frequency shift capacitance continuous level transmitter for non-conductive liquids and solids applications.

Approvals

General Safety (CSA, FM, CE, C-TICK)

Dust Ignition Proof With IS Probe

CE, C-TICK, ATEX II 1/2 D T100 °C

Flame Proof Enclosure With IS Probe

CE, C-TICK, ATEX II 1/2 G EEx d [ia] IIC T6...T1,

ATEX II 1/2 D T100 °C

Dust Ignition Proof With IS Probe

CSA/FM Class II, Div. 1, Groups E, F, G

CSA/FM Class III T4

Explosion Proof Enclosure With IS Probe

CSA/FM Class I, Div. 1, Groups A, B, C, D

CSA/FM Class II, Div. 1, Groups E, F, G

CSA/FM Class III T4

Enclosure

Aluminum epoxy coated 2 x 1½" NPT via adapter - cable inlet, IP65

Aluminum epoxy coated 2 x M20 x 1.5 cable inlet, IP65

Aluminum epoxy coated 2 x 1½" NPT via adapter - cable inlet, IP68

Aluminum epoxy coated 2 x M20 x 1.5 cable inlet, IP68

- ¹⁾ Flange bolting patterns and facings dimensionally correspond to the applicable ASME B16.5 or EN 1092-1 standard.
- ²⁾ Cable lengths from 15 000 (590.55 inch) to 25 000 mm (984.25 inch) can be used in non-conductive media. Contact Factory for assistance.

Level Measurement

Continuous level measurement – Capacitance transmitters

SITRANS LC300

Selection and Ordering data	Order code
Further designs	
Please add "-Z" to Article No. and specify Order code(s).	
Insertion length, specify in plain text: Y01: ... mm	Y01
Stainless steel tag [69 x 50 mm (2.71 x 1.97 inch)]; Measuring-point number/identification (max. 27 characters) specify in plain text	Y15
Manufacturer's Test Certificate: M to DIN 55350, Part 18 and to ISO 9000	C11
Inspection Certificate Type 3.1 per EN 10204	C12
Operating Instructions	
English	7ML1998-5HE03
French	7ML1998-5HE11
German	7ML1998-5HE33
Spanish	7ML1998-5HE21
Multi-language Quick Start manual	7ML1998-5QH81
Note: The Operating Instructions should be ordered as a separate line item on the order.	
This device is shipped with the Siemens Milltronics manual DVD containing the ATEX Quick Start and Operating Instructions library.	
Accessories	
Electronic transmitter kit (includes transmitter and driver)	7ML1830-1KN
SITRANS RD100 Remote display - see Chapter 7	
SITRANS RD200 Remote display - see Chapter 7	
SITRANS RD500 web, datalogging, alarming, ethernet, and modem support for instrumentation - see Chapter 7	7ML5750-1AA00-0

Level Measurement

Continuous level measurement – Capacitance transmitters

SITRANS LC300

Selection and Ordering data

Article No.

SITRANS LC300, PFA coated cable version

7ML5673-

An inverse frequency shift capacitance continuous level transmitter for liquids and solids applications.

Process connection

Threaded, 316L stainless steel
 1½" NPT [(Taper), ANSI/ASME B1.20.1]
 R 1½" [(BSPT), EN 10226/PT (JIS-T), JIS B 0203]
 G 1½" [(BSPP), EN ISO 228-1/PF (JIS-P), JIS B 0202]
Welded flange, 316L stainless steel, raised face¹⁾

1½" ASME, 150 lb
 1½" ASME, 300 lb
 1½" ASME, 600 lb

2" ASME, 150 lb
 2" ASME, 300 lb
 2" ASME, 600 lb

3" ASME, 150 lb
 3" ASME, 300 lb
 3" ASME, 600 lb

4" ASME, 150 lb
 4" ASME, 300 lb
 4" ASME, 600 lb

Welded flange, 316L stainless steel, Type A flat faced¹⁾

DN 40, PN 16
 DN 40, PN 40
 DN 50, PN 16

DN 50, PN 40
 DN 80, PN 16
 DN 80, PN 40

DN 100, PN 16
 DN 100, PN 40

Probe Length

(from flange face or including process thread)

Add Order code Y01 and plain text:
 "Insertion length ... mm"

1 000 ... 2 000 mm (39.37 ... 78.74 inch)

2 001 ... 4 000 mm (78.78 ... 157.48 inch)

4 001 ... 6 000 mm (157.52 ... 236.22 inch)

6 001 ... 8 000 mm (236.26 ... 314.96 inch)

8 001 ... 10 000 mm (315.00 ... 393.70 inch)

10 001 ... 12 000 mm (393.74 ... 472.44 inch)

12 001 ... 14 000 mm (472.48 ... 551.18 inch)

14 001 ... 16 000 mm (551.22 ... 629.92 inch)²⁾

16 001 ... 18 000 mm (629.96 ... 708.66 inch)²⁾

18 001 ... 20 000 mm (708.70 ... 787.40 inch)²⁾

20 001 ... 22 000 mm (787.44 ... 866.14 inch)²⁾

22 001 ... 24 000 mm (866.18 ... 944.88 inch)²⁾

24 001 ... 25 000 mm (944.92 ... 984.25 inch)²⁾

Thermal isolator

Without thermal isolator

With thermal isolator [for process connection temperatures over 85 °C (185 °F)]

Wetted seals

FKM

FFKM [for process temperatures above -20 °C (-4 °F)]

0 D

1 D

3 D

5 D

5 E

5 F

5 G

5 H

5 J

5 K

5 L

5 M

5 N

5 P

5 Q

6 C

6 D

6 E

6 F

6 G

6 H

6 J

6 K

A

B

C

D

E

F

G

H

J

K

L

M

N

0

1

0

1

Selection and Ordering data

Article No.

SITRANS LC300, PFA coated cable version

7ML5673-

An inverse frequency shift capacitance continuous level transmitter for liquids and solids applications.

Probe material

PFA coated cable and 316L stainless steel cable weight, PEEK isolator and PFA lined active shield

Approvals

General Safety (CSA, FM, CE, C-TICK)
 Dust Ignition Proof With IS Probe
 CE, C-TICK, ATEX II 1/2 D T100 °C

Flame Proof Enclosure With IS Probe

CE, C-TICK, ATEX II 1/2 G EEx d [ia] IIC T6...T1, ATEX II 1/2 D T100 °C

Dust Ignition Proof With IS Probe

CSA/FM Class II, Div. 1, Groups E, F, G
 CSA/FM Class III T4

Explosion Proof Enclosure With IS Probe
 CSA/FM Class I, Div. 1, Groups A, B, C, D
 CSA/FM Class II, Div. 1, Groups E, F, G
 CSA/FM Class III T4

Enclosure

Aluminum epoxy coated 2 x ½" NPT via adapter - cable inlet, IP65

Aluminum epoxy coated 2 x M20 x 1.5 cable inlet, IP65

Aluminum epoxy coated 2 x ½" NPT via adapter - cable inlet, IP68

Aluminum epoxy coated 2 x M20 x 1.5 cable inlet, IP68

Mounting eye

Without Mounting eye

With mounting eye

¹⁾ Flange bolting patterns and facings dimensionally correspond to the applicable ASME B16.5 or EN 1092-1 standard.

²⁾ Cable lengths from 15 000 (590.55 inch) to 25 000 mm (984.25 inch) can be used in non-conductive media. Contact Factory for assistance.

1

A

B

C

D

E

A

B

C

D

0

1

Level Measurement

Continuous level measurement – Capacitance transmitters

SITRANS LC300

Selection and Ordering data	Order code
Further designs	
Please add "-Z" to Article No. and specify Order code(s).	
Insertion length, specify in plain text: Y01: ... mm	Y01
Stainless steel tag [69 x 50 mm (2.71 x 1.97 inch)]; Measuring-point number/identification (max. 27 characters) specify in plain text	Y15
Manufacturer's Test Certificate: M to DIN 55350, Part 18 and to ISO 9000	C11
Inspection Certificate Type 3.1 per EN 10204	C12
Operating Instructions	
English	7ML1998-5HE03
French	7ML1998-5HE11
German	7ML1998-5HE33
Spanish	7ML1998-5HE21
Multi-language Quick Start manual	7ML1998-5QH81
Note: The Operating Instructions should be ordered as a separate line item on the order. This device is shipped with the Siemens Milltronics manual DVD containing the ATEX Quick Start and Operating Instructions library.	
Accessories	
Electronic transmitter kit (includes transmitter and driver)	7ML1830-1KN
SITRANS RD100 Remote display - see Chapter 7	
SITRANS RD200 Remote display - see Chapter 7	
SITRANS RD500 web, datalogging, alarming, ethernet, and modem support for instrumentation - see Chapter 7	7ML5750-1AA00-0

Level Measurement

Continuous level measurement – Capacitance transmitters

SITRANS LC300

Characteristic curves

Pressure/temperature curve
LC300 standard, extended rod and cable probes
Threaded process connections
(7ML5670, 7ML5671, 7ML5672 and 7ML5673)

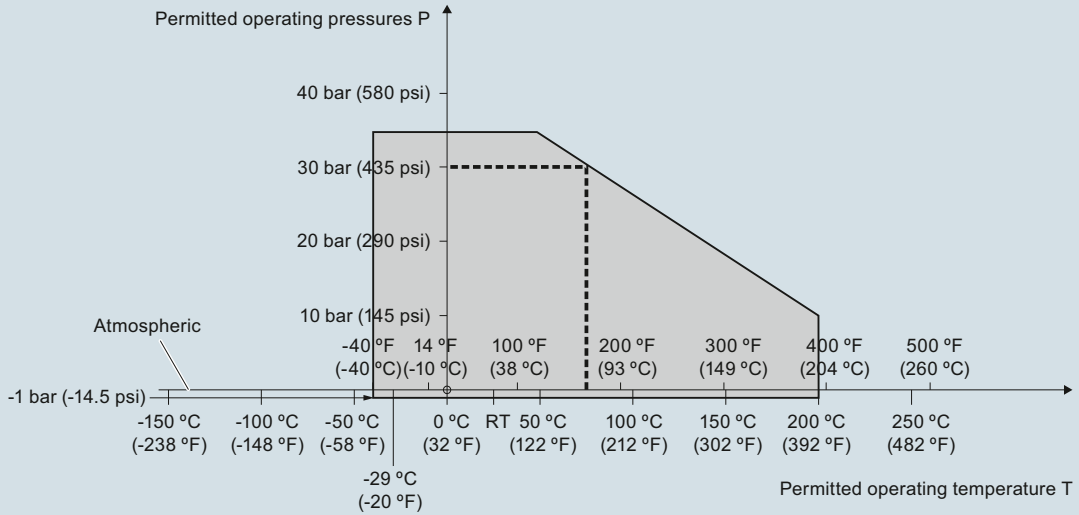

----- Example:
 ermitted operating pressure = 30 bar (435 psi) at 75 °C

SITRANS LC300 Process Pressure/Temperature derating curves (7ML5625)

4

Level Measurement

Continuous level measurement – Capacitance transmitters

SITRANS LC300

Pressure/temperature curve
LC300 standard, extended rod and cable probes
ASME flanged process connections
(7ML5670, 7ML5671, 7ML5672 and 7ML5673)

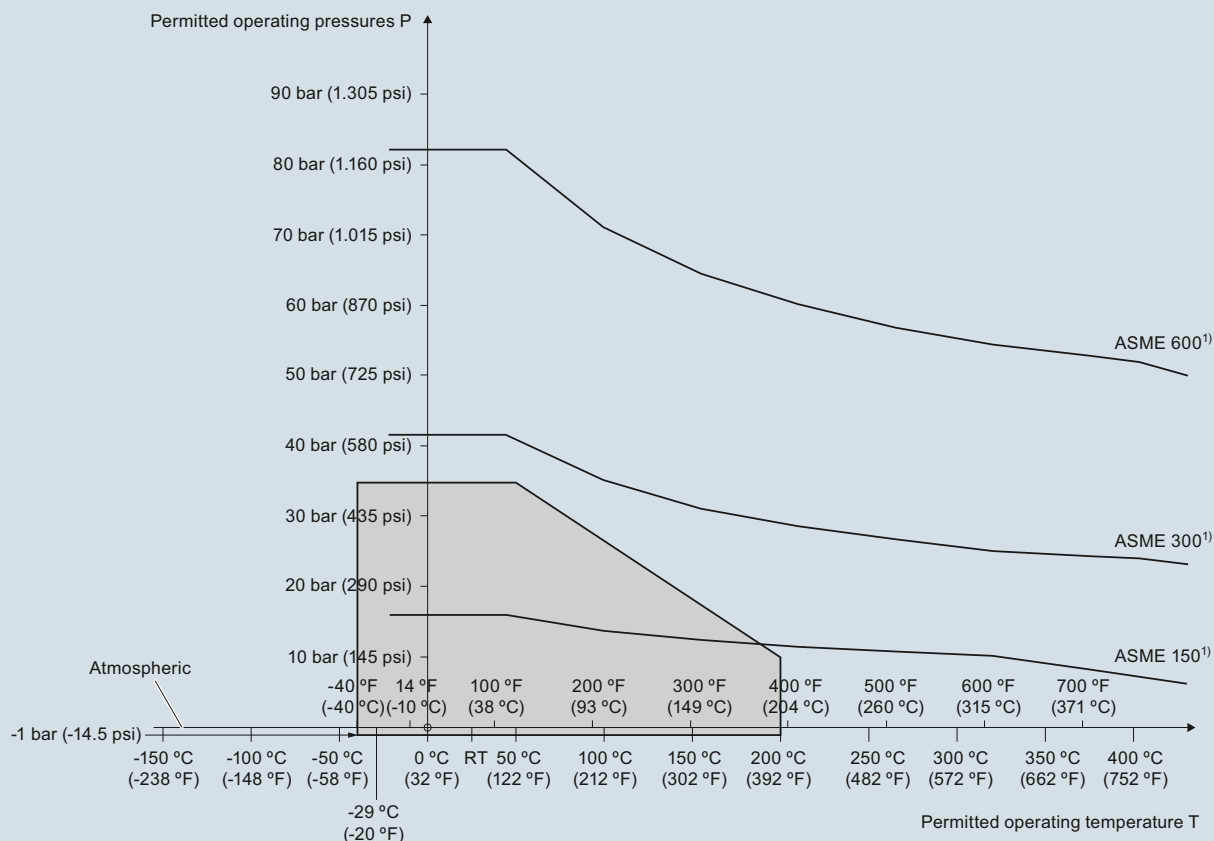

¹⁾ The curve denotes the minimum allowable flange class for the shaded area below.

SITRANS LC300 Process Pressure/Temperature derating curves (7ML5626)

Pressure/temperature curve
LC300 standard, extended rod and cable probes
EN flanged process connections
(7ML5670, 7ML5671, 7ML5672 and 7ML5673)

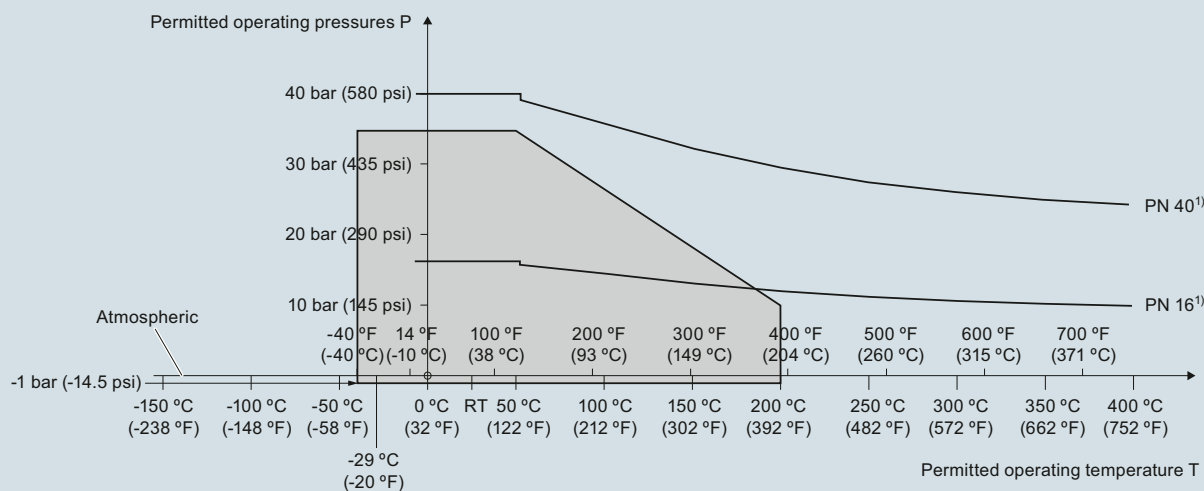

¹⁾ The curve denotes the minimum allowable flange class for the shaded area below.

SITRANS LC300 Process Pressure/Temperature derating curves (7ML5626)

Level Measurement

Continuous level measurement – Capacitance transmitters

SITRANS LC300

Dimensional drawings

Threaded (7ML5670)

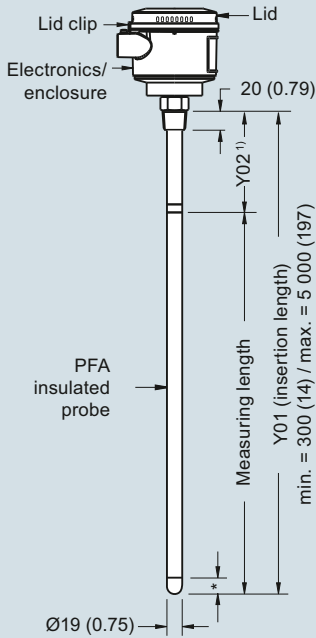

* = 30 (1.18) Inactive tip

Threaded (7ML5671)

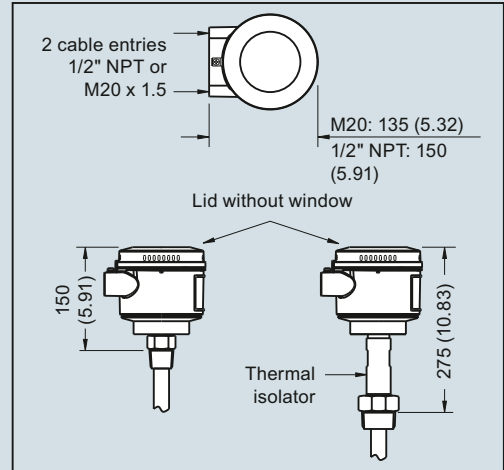
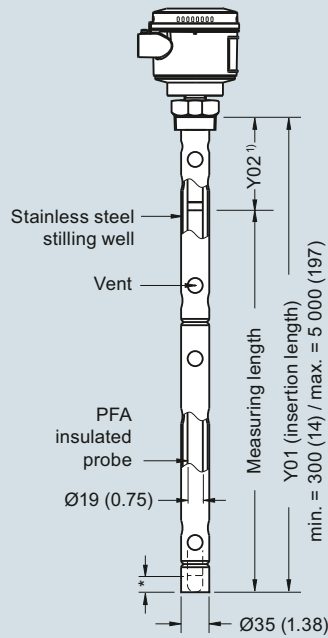

Note:

- 1) Rod version Y02: Shield length = 100 mm (3.9 inch) for threaded including process connection thread length, 100 mm (3.9 inch) for welded flange
- 2) For non-conductive applications only. Non-insulated cable can be shortened on site. Weight is included in measuring length.
- 3) For liquids and solids applications. Insulated cable cannot be shortened. Weight is **not** included in measuring length.
- 4) For conductive materials, the measuring length includes the exposed PFA insulated cable only. Any fluid contact with the upper rod assembly will result in a short circuit and incorrect readings.

Cable version, non-insulated ²⁾
Threaded (7ML5672)

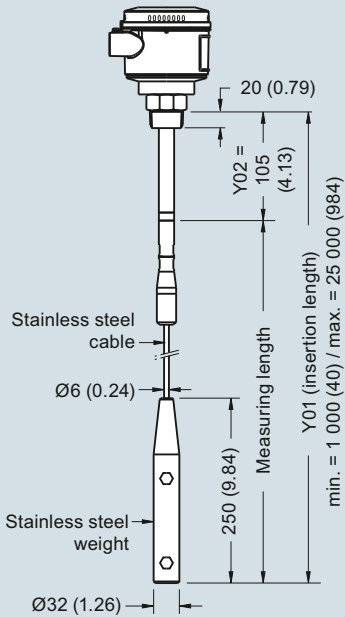

Cable version, insulated ³⁾
Threaded (7ML5673)

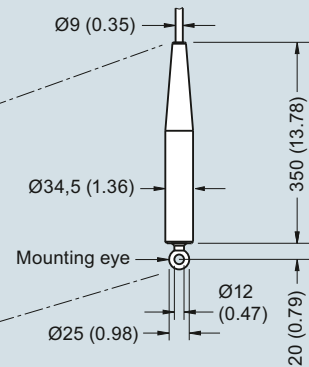
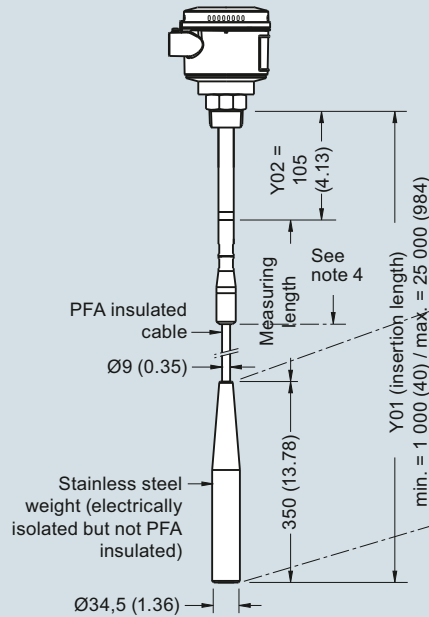

SITRANS LC300 - Threaded Process Connections, dimensions in mm (inch)

Level Measurement

Continuous level measurement – Capacitance transmitters

SITRANS LC300

Welded Flange (7ML5670)

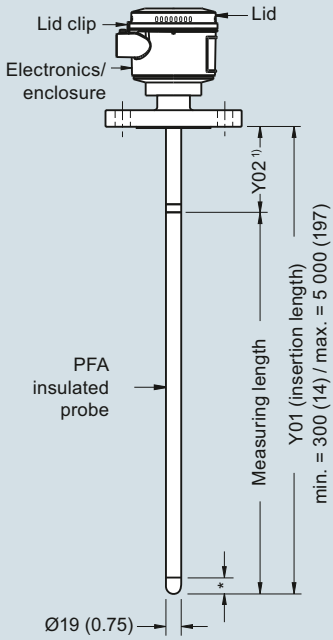

* = 30 (1.18) inactive tip

Welded Flange (7ML5671)

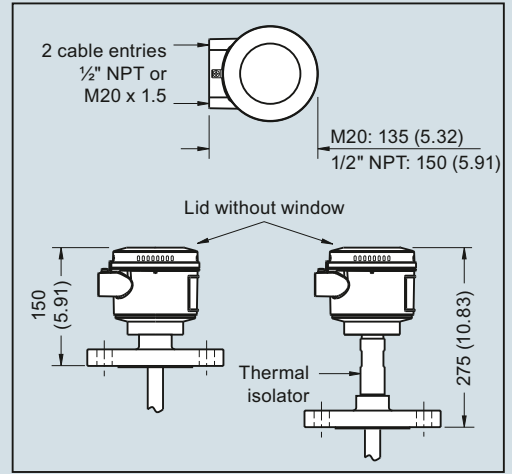
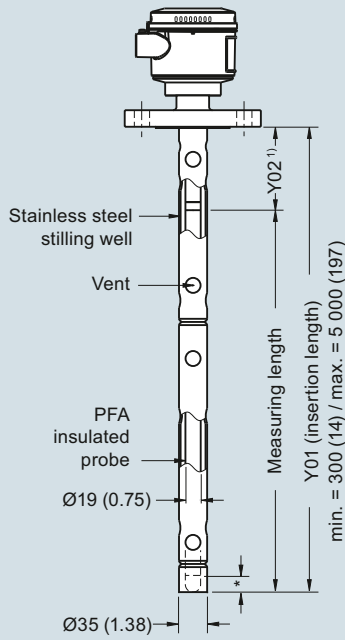

Flange Facing (raised face)

Flange Class	Facing thickness
△ ASME 150/300	2 (0.08)
△ ASME 600/900	7 (0.28)
△ PN16/40	2 (0.08)

Notes:

- 1) Rod version Y02: Shield length = 100 mm (3.9 inch) for threaded including process connection thread length, 100 mm (3.9 inch) for welded flange.
- 2) For non-conductive applications only. Non-insulated cable can be shortened on site. Weight is included in measuring length.
- 3) For liquids and solids applications. Insulated cable cannot be shortened. Weight is **not** included in measuring length.
- 4) For conductive materials, the measuring length includes the exposed PFA insulated cable only. Any fluid contact with the upper rod assembly will result in a short circuit and incorrect readings.

Cable version, non-insulated²⁾ Welded Flange (7ML5672)

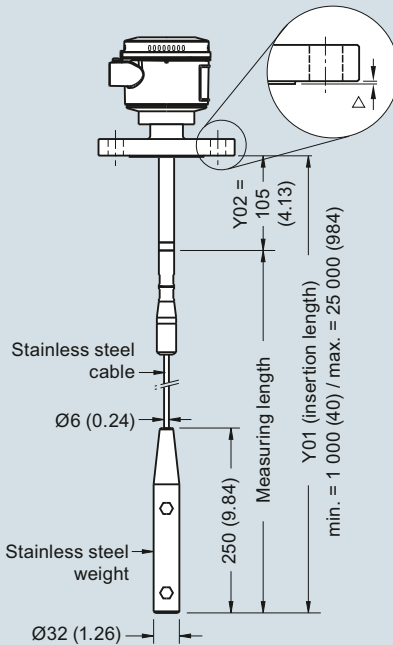

Cable version, insulated³⁾ Welded Flange (7ML5673)

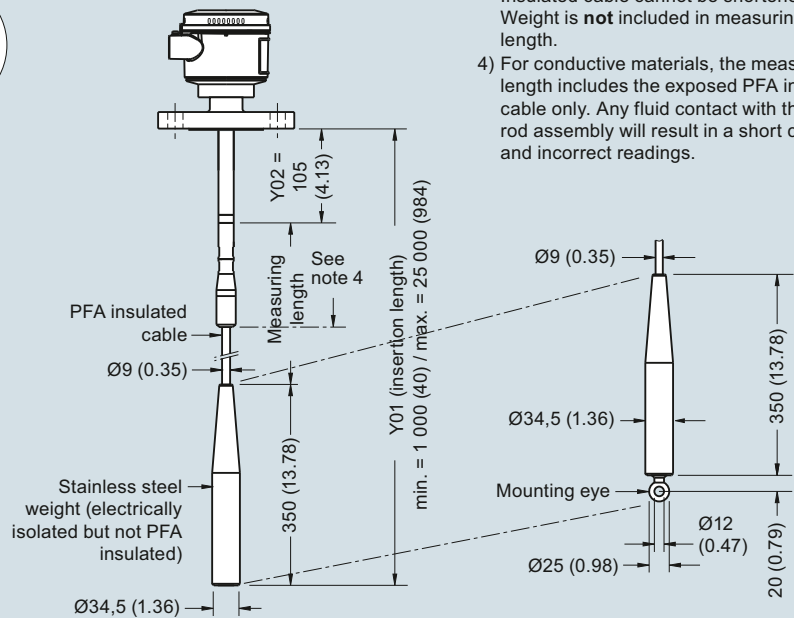

SITRANS LC300 - Flanged Process Connections, dimensions in mm (inch)

Level Measurement

Continuous level measurement – Capacitance transmitters

SITRANS LC300

Schematics

With safety barrier	Without safety barrier
white (S)	orange (S)
black (O)	black (O)
red (+)	red (+)

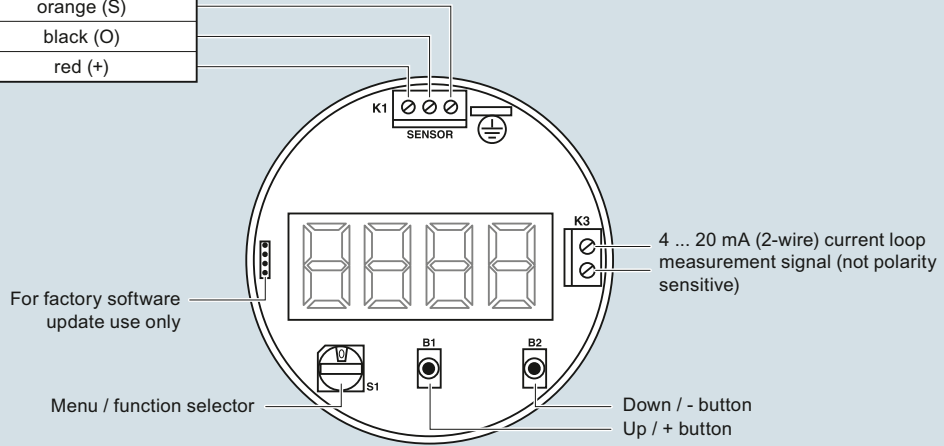

SITRANS LC300 connections

4



Level Measurement

Continuous level measurement – Capacitance transmitters





SITRANS LC300 and LC500 Specials

Selection and ordering data

LC300 and LC500 Specials¹⁾

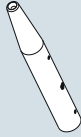
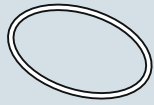
	Article No.
LC300 Cable Extensions, 316L stainless steel	
Kit, stainless steel cable extension, 1 m, adjustable by customer	A5E01163688
Kit, stainless steel cable extension, 3 m, adjustable by customer	A5E01163689
Kit, stainless steel cable extension, 5 m, adjustable by customer	A5E01163690
Kit, stainless steel cable extension, 10 m, adjustable by customer	A5E01163691
Kit, stainless steel cable extension, 15 m, adjustable by customer	A5E01163693
Kit, stainless steel cable extension, 20 m, adjustable by customer	A5E01163695
LC300 Cable Extensions, 316 stainless steel with PFA coating	
Kit, PFA cable extension, 1 m	A5E01163709
Kit, PFA cable extension, 3 m	A5E01163710
Kit, PFA cable extension, 5 m	A5E01163711
Kit, PFA cable extension, 10 m	A5E01163712
Kit, PFA cable extension, 15 m	A5E01163713
Kit, PFA cable extension, 20 m	A5E01163714

LC300 and LC500 Specials¹⁾

	Article No.
LC300 Mounting Eye	
Spare mounting eye (LC300 PFA versions only)	A5E01163717
LC300 Weight Kit, 316L stainless steel	
Kit, Spare stainless steel weight. To be used in any cable version of CLS300, or stainless steel cable version of LC300	A5E01163727
LC500 Gasket (IP65), Silicone	
Spare gasket, LC500 enclosure version, IP65	A5E01163728
LC500 Blind Lid	
Spare LC500 aluminum blind lid	A5E01163729
LC500 Mounting Eye	
Spare mounting eye (PFA cable version only)	A5E01163717
LC500 Mounting Bracket	
Spare mounting bracket	A5E01163730
LC500 Sanitary Versions²⁾	

¹⁾ Special flange sizes and facings are available. Please contact ceg.smpi@siemens.com for part number and pricing. Submit Application Questionnaire found on page 4/11.

²⁾ Please contact ceg.smpi@siemens.com for part number and pricing. Submit Application Questionnaire found on page 4/11.

Please contact ceg.smpi@siemens.com for special requests.