

# Rosemount™ 2110 Level Switch

## Vibrating Fork



- Virtually unaffected by turbulence, foam, vibration, coating, or changing liquid properties
- Built in diagnostics continuously monitors instrument health and Heartbeat LED provides visual indication
- Magnetic test point makes testing of the Rosemount 2110 and system easy
- Minimal installation and maintenance, and no calibration required, keeps costs down
- DIBt / WHG overfill protection certification keeps peace of mind
- Compact size makes the Rosemount 2110 suitable for use in small vessels and tanks or for in-pipe mounting
- Hygienically certified to 3-A® and EHEDG, and complies with FDA and ASME-BPE



# Overview of the Rosemount 2110 Level Switch



Threaded process connection



Tri Clamp process connection



Compact and lightweight

## Measurement principle

The Rosemount 2110 is designed using the principle of a tuning fork. A piezo-electric crystal oscillates the forks at their natural frequency. Changes to this frequency are continuously monitored. The frequency of the vibrating fork sensor changes depending on the medium in which it is immersed. The denser the liquid, the lower the frequency.

When used as a **low level alarm**, the liquid in the tank or pipe drains down past the fork, causing a change of natural frequency that is detected by the electronics and switches the output state.

When the Rosemount 2110 is used as a **high level alarm**, the liquid rises in the tank or pipe, making contact with the fork which then causes the output state to switch.

## Key features and benefits

- Stainless steel housing and plug/socket connection for fast-fit, high-volume users
- Compact and lightweight design for side or top mounting
- The industry standard DIN 43650 plug/socket is used for a fast connection. The polarity insensitivity and short circuit protection make electrical hook-up safe and easy
- The Rosemount 2110 is designed for operation in temperatures from -40 to 302 °F (-40 to 150 °C)
- Rapid wet-to-dry time for highly responsive switching
- ‘Fast Drip’ fork design gives quicker response time, especially with viscous liquids
- The ‘heartbeat’ LED gives an instant visual indication that the unit is operational
- Fork shape is optimized for polishing to meet hygienic requirements. Mechanical-polishing and electro-polishing options
- No moving parts or crevices for virtually no maintenance
- Magnetic test point makes functional test easy

## Contents

Overview of the Rosemount 2110 Level Switch .. page 2  
 Ordering Information ..... page 4  
 Spare Parts and Accessories ..... page 5

Specifications ..... page 6  
 Product Certifications ..... page 8  
 Dimensional Drawings ..... page 9

## Fit and forget

- Once installed, the Rosemount 2110 is ready to go. It needs no calibration and requires minimum installation
- Functional testing of the instrument and system is easy with a magnetic test point
- You can install, and forget it

## Superior performance

- Functionality is virtually unaffected by turbulence, foam, vibration, coating, or liquid properties
- The 'Fast Drip' design allows the liquid to be quickly drawn away from the fork tip, making the Rosemount 2110 quicker and more responsive in high density or viscous liquid applications

## Applications

- Overfill protection
- High and low level alarms
- Leak detection
- Run dry or pump protection
- Pump control or limit detection
- Hygienic applications

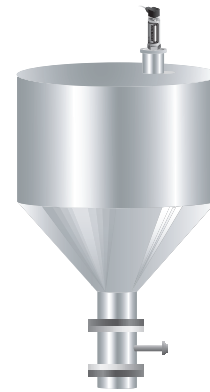

Overfill protection



High and low level alarm

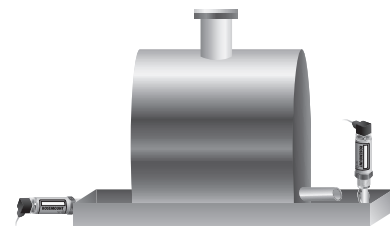

Leak detection



Pump protection

## Ordering Information

Specification and selection of product materials, options, or components must be made by the purchaser of the equipment. See [page 6](#) for more information on Material Selection.

**Table 1. Rosemount 2110 Ordering Information**

The starred options (★) represent the most common options and should be selected for best delivery. Any non-starred offerings are subject to additional delivery lead time.

Model	Product description	
2110	Compact Vibrating Fork Liquid Level Switch	
<b>Electronic type</b>		
0	Direct load switching with plug connection (2 wire) 21 to 264 Vac 50/60Hz, 21 to 264 Vdc	★
1	PNP/PLC low voltage switching with plug connection 18 to 60 Vdc	★
<b>Process connection size / type</b>		
0A	<sup>3</sup> / <sub>4</sub> -in. BSPT (R) thread	★
1A	1-in. BSPT (R) thread	★
0D	<sup>3</sup> / <sub>4</sub> -in. NPT thread	★
2R	2-in. (51 mm) Tri Clamp	★
1B	1-in. BSPP (G) thread	★
1L	1-in. BSPP (G) semi-extended 4.6 in. (116 mm)	★
<b>Surface finish</b>		<b>Available Connections</b>
1	Standard surface finish	All
2 <sup>(1)</sup>	Hand polished (Ra < 0.4 μm)	Tri Clamp only
3	Ra < 0.76 μm, hygienically approved	Tri Clamp only
4	Electro-polished to ≤ 0.76 μm, hygienically approved	Tri Clamp only
7	Mechanically-polished to Ra < 0.1 μm, hygienically approved	Tri Clamp only
8	Electro-polished to Ra < 0.38 μm, hygienically approved	Tri Clamp only
<b>Product certificates<sup>(2)</sup></b>		
NA	No hazardous locations certifications (safe area use only)	★
<b>Typical Model Number: 2110 0 2R 1 NA</b>		

### Options (include with the selected model number)

<b>Calibration data certificate</b>		
Q4	Certificate of functional test	★
<b>Wetted surface finish certification<sup>(3)</sup></b>		
Q16	Surface finish certification	★
<b>3-A certification<sup>(3)</sup></b>		
QA	Certificate of compliance to 3-A	★
<b>EHEDG certification<sup>(3)</sup></b>		
QE	Certificate of compliance to EHEDG	★

**Table 1. Rosemount 2110 Ordering Information**

The starred options (★) represent the most common options and should be selected for best delivery. Any non-starred offerings are subject to additional delivery lead time.

ASME BPE certification <sup>(3)</sup>		
QB	Declaration of conformity to ASME BPE	★
FDA certification <sup>(3)</sup>		
QH	Declaration of conformity to FDA	★
Tag plate		
ST	Tag plate SST engraved plate (maximum 16 digits), wire-on	★
WT	Tag plate laminated paper (maximum 40 digits)	★
Overfill		
U1	WHG/DIBt overfill protection	★
<b>Example of options included with the model number: 2110 0 2R 1 NA Q4 ST U1</b>		

1. Hand-polished for hygienic connections to better than 0.4 μm Ra such that there are no pits, folds, crevices or cracks discernible to the naked eye (i.e. no features larger than 75 micrometers based on resolving 1/60 degree at a distance of 250 mm).
2. Includes the Technical Regulation Customs Union (EAC) ordinary location mark.
3. Available only for a Rosemount 2110 with a Tri Clamp fitting and Surface Finish code 3, 4, 7, or 8.

## Spare Parts and Accessories

Specification and selection of product materials, options, or components must be made by the purchaser of the equipment. See [page 6](#) for more information on Material Selection.

**Table 2. Spare Parts and Accessories**

The starred options (★) represent the most common options and should be selected for best delivery. Any non-starred offerings are subject to additional delivery lead time.

Part number	Description	
02100-1000-0001	Seal for 1-in. BSPP (G1A). Material: Non-asbestos BS7531 grade X carbon fiber with rubber binder	★
02100-1010-0001	Adaptor boss 1-in. BSPP to 1 <sup>1</sup> / <sub>2</sub> -in. (38mm) Tri Clamp. Material: 316 SST fitting, FPM/FKM O-ring	★
02100-1020-0001 <sup>(1)</sup>	2-in. (51 mm) Tri Clamp kit (vessel fitting, clamp ring, and seal). Material: 316 SST, NBR Nitrile	★
02100-1030-0001	Telescopic test magnet	★

1. This is not approved to be used with a 3-A or EHEDG approved products and is not assessed for use with FDA or ASME-BPE compliant products.

# Specifications

## General

### Product

Rosemount 2110 Compact Level Switch

### Measuring principle

Vibrating fork

### Applications

Most liquids including coating liquids, aerated liquids, and slurries

## Mechanical

### Mounting connections

$\frac{3}{4}$ -in. BSPT (R) or NPT,  
1-in. BSPT (R) or BSPP (G) thread, or  
Hygienic 2-in. (51 mm) Tri Clamp fitting

### Materials selection

Emerson provides a variety of Rosemount product with various product options and configurations including materials of construction that can be expected to perform well in a wide range of applications. The Rosemount product information presented is intended as a guide for the purchaser to make an appropriate selection for the application. It is the purchaser's sole responsibility to make a careful analysis of all process parameters (such as all chemical components, temperature, pressure, flow rate, abrasives, contaminants, etc.), when specifying product, materials, options and components for the particular application. Emerson is not in a position to evaluate or guarantee the compatibility of the process fluid or other process parameters with the product, options, configuration or materials of construction selected.

### Process connection materials

316L stainless steel (1.4404)

Gasket material for 1 in. BSPP (G1) is Non-asbestos BS7531 Grade X carbon fiber with rubber binder.

### Transmissible Spongiform Encephalopathy (TSE) declaration

Emerson™ certifies no process wetted components used in this product contain substances of animal origin. Materials used in the production or processing of wetted components for this product meet the requirements stated in EMA/410/01 Rev. 3 and ISO 22442-1:2015. Wetted components in this product are considered free of TSE.

This declaration is applicable to the 2-in. (51 mm) Tri Clamp connection option when ordered with Surface Finish option codes 3, 4, 7 and 8.

### Housing / enclosure materials

Body: 304 SST with polyester label

LED window: Flame retardant Polyamide (Pa12) UL94 V2

Plug: Polyamide glass reinforced

Plug seals: Nitrile butadiene rubber

### Ingress protection rating

IP66/67 to EN60529

## Performance

### Hysteresis (water)

$\pm 0.039$ -in. ( $\pm 1$  mm) nominal

### Switching point (water)

0.5 in. (13 mm) from fork tip if mounted vertically

0.5 in. (13 mm) from the fork edge if mounted horizontally

The switch point varies with different liquid densities.

## Functional

### Maximum operating pressure

The final rating depends on the process connection.

Threaded connection: see [Figure 1](#)

Hygienic connection: 435 psig (30 barg)

**Figure 1. Process Pressure**

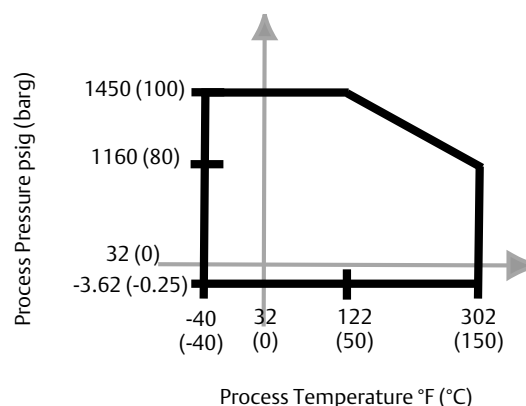

**Minimum and maximum operating temperatures**

See Figure 2 for the maximum and minimum operating temperatures.

**Figure 2. Temperature**

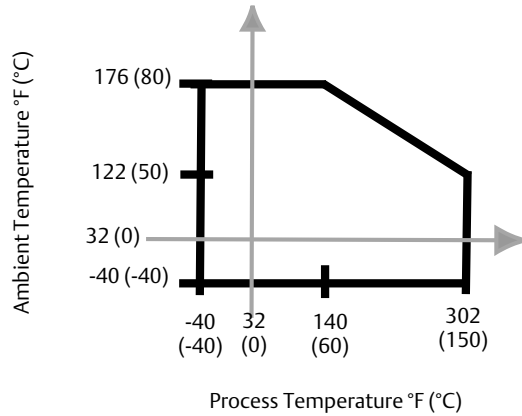

**Liquid density requirement**

Minimum 37.5 lb/ft<sup>3</sup> (600 kg/m<sup>3</sup>)

**Liquid Viscosity Range**

0.2 to 10000 cP (centiPoise)

**Solids content and coating**

Maximum recommended diameter of solid particles in the liquid is 0.2 in. (5 mm). For coating product, avoid ‘bridging’ of forks.

**Switching delay**

1 second delay for dry-to-wet or wet-to-dry switching

**CIP (Clean In Place) cleaning**

Withstands steam cleaning routines up to 302 °F (150 °C)

**Electrical**

**Switching mode**

User selectable (Dry=on or Wet=on) by selecting plug wiring

**Protection**

Polarity insensitive – Direct Load electronics only, over-current protection, short-circuit protection, load-missing protection, and surge protection (to IEC61326)

**Magnetic test point**

A magnetic test point is located on the side of the housing, allowing a functional test of the Rosemount 2110 and a system connected to it. By holding a magnet to the target, the output changes state for as long as the magnet is held there.

**Cable connection**

Via 4-way plug provided (DIN43650)

Maximum conductor size is 15AWG

4-position orientation (90° / 180° / 270° / 360°)

**Terminal connection (wire diameter)**

Maximum 0.06 in.<sup>2</sup> (1.5 mm<sup>2</sup>)

**Cable gland**

PG9 provided. Cable diameter 0.24 to 0.31 in. (6 to 8 mm)

**Grounding**

Always ground the Rosemount 2110 either through the terminals or using the external ground connection provided.

**Electronics options**

**Figure 3. Direct Load Switching (Electronics Code 0)**

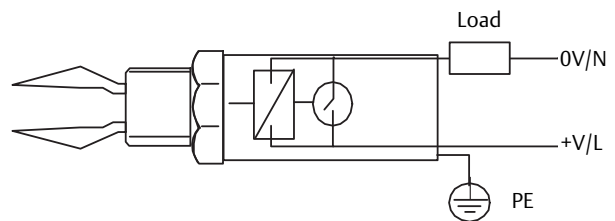

Direct load switching (electronics code 0)	
Operating voltage	21 to 264 Vac (50 to 60 Hz)/dc
Maximum switched load	500 mA
Maximum peak load	5 A for 40 ms maximum
Minimum switched load	20 mA continuous
Voltage drop	6.5 V @ 24 Vdc / 5 V @ 240 Vac
Current draw (load off)	< 3.0 mA continuous

**Figure 4. PNP Switching (Electronics Code 1)**

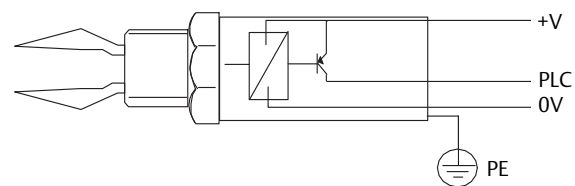

PNP switching (electronics code 1)	
Operating voltage	18 to 60 Vdc
Maximum switched load	500 mA
Maximum peak load	5 A for 40 ms maximum
Voltage drop	< 3 V
Supply current	3 mA nominal
Output current (load off)	< 0.5 mA

# Product Certifications

## European Union directive information

A copy of the EU Declaration of Conformity can be found at the end of the Rosemount 2110 [Quick Start Guide](#).

The most recent revision of the EU Declaration of Conformity can be found at [Emerson.com/Rosemount](http://Emerson.com/Rosemount).

## Overfill protection

If required, select Product Certificates code U1 for DIBt/WHG overfill protection. The approval number is Z-65.11-236.

## Hygienic certifications and compliances (surface finish codes 3, 4, 7, and 8)

**3-A** Authorization (3496)

**EHEDG** Certificate: (102016)

**ASME-BPE** and **FDA** compliant.

## Canadian Registration Number (CRN)

The CRN is 0F04227.2C for model numbers with a NPT threaded process connection selected.

## Technical Regulation Customs Union (EAC), ordinary locations mark

### TRCU 004/2011

Certificate: TR RU C-GB.AB72.B.01974

EN61010-1 Pollution degree 2, Category II (264V maximum),  
Pollution degree 2, Category III (150 V maximum)

### TRCU 020/2011

Certificate: TCRU C-GB.AB72.B.00916

EN61326



# Dimensional Drawings

Figure 5. Threaded Process Connections

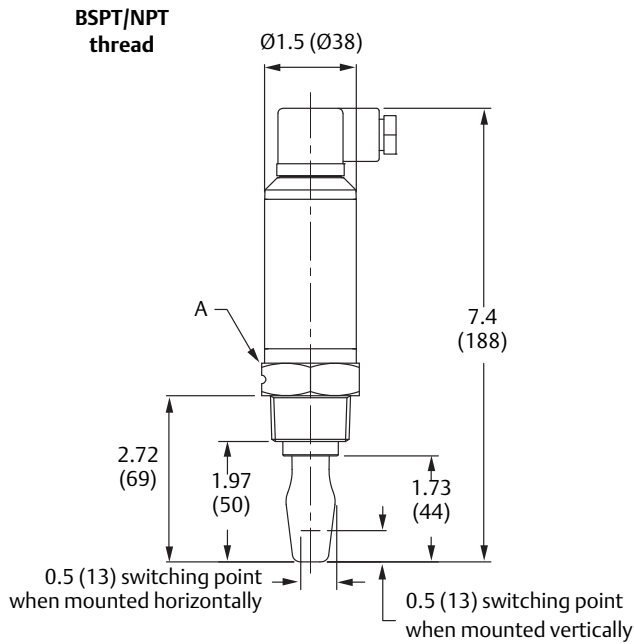
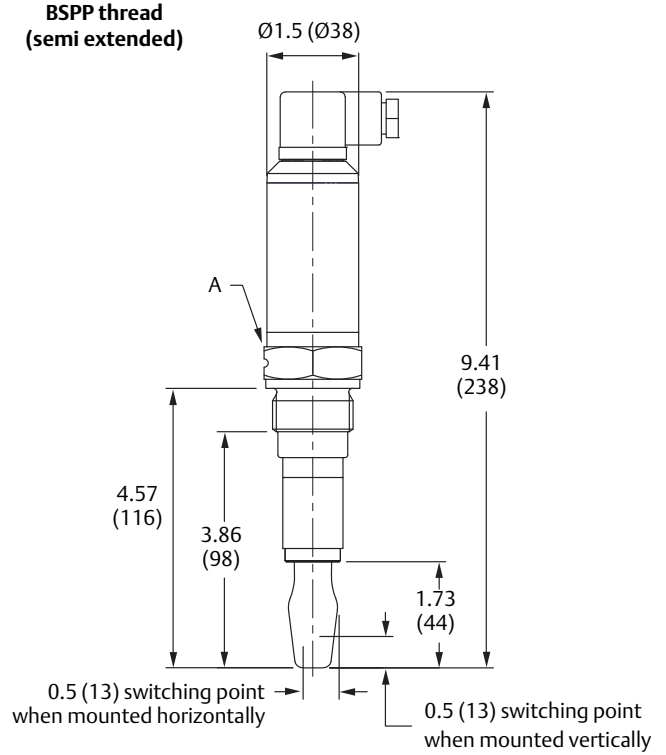
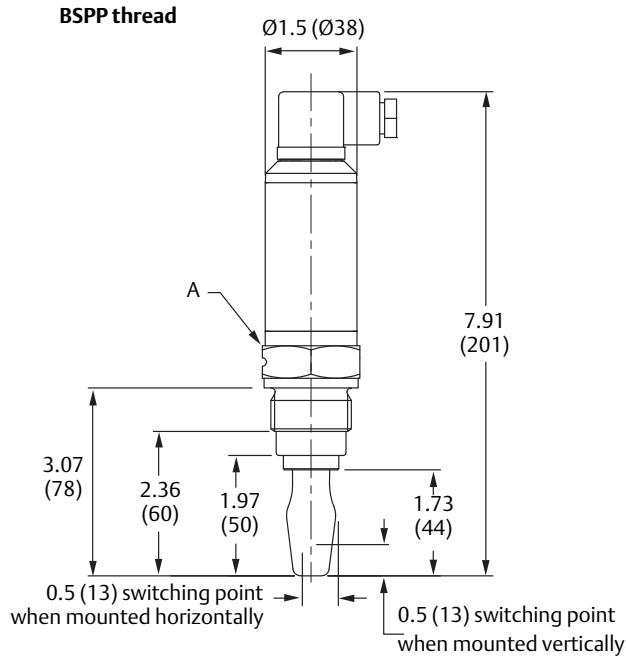

A. 1.61 (41) A/F hexagon with fork orientation groove

Dimensions are in inches (mm).

Figure 6. Tri Clamp Process Connection

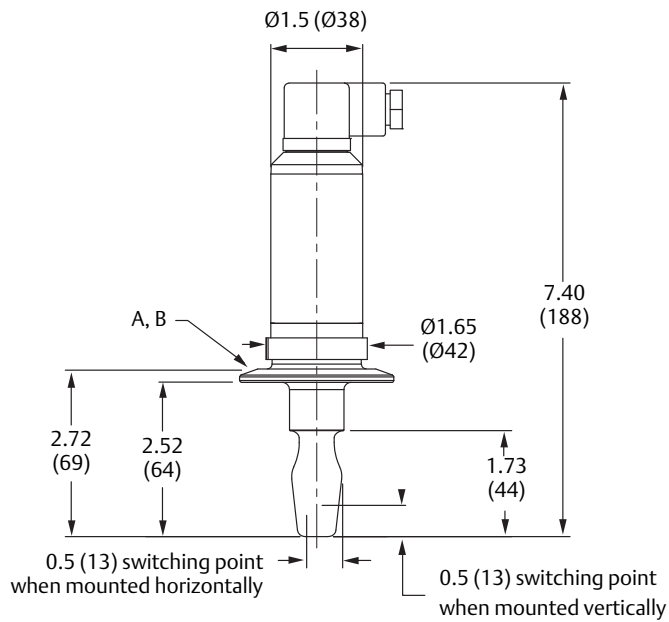

A. 2-in. (51 cm) Tri Clamp, hygienically certified (surface finish codes 3, 4, 7, and 8)

B. 2-in. (51 cm) Tri Clamp, not hygienically certified (surface finish codes 1 and 2)

C. 1.61 (41) A/F hexagon with fork orientation groove

Dimensions are in inches (mm).