

EE160

HVAC Humidity and Temperature Transmitter

Specially designed for HVAC, the EE160 sensor by E+E Elektronik is a cost-effective, highly accurate and reliable solution for measuring relative air humidity and temperature.

The enclosure minimizes installation costs and provides outstanding protection against contamination and condensation, thus ensuring flawless operation.

The EE160 employs the new humidity/temperature E+E sensor element HCT01 with excellent long term stability and resistance against pollutants. In combination with a long calibration experience, the EE160 provides a measurement accuracy of $\pm 2.5\%RH$ and is available for wall or duct-mounted with current, voltage or Modbus RTU output.



The configuration equipment allows user setup for the output scaling and for the interface parameters, as well as humidity and temperature adjustment of the sensor.

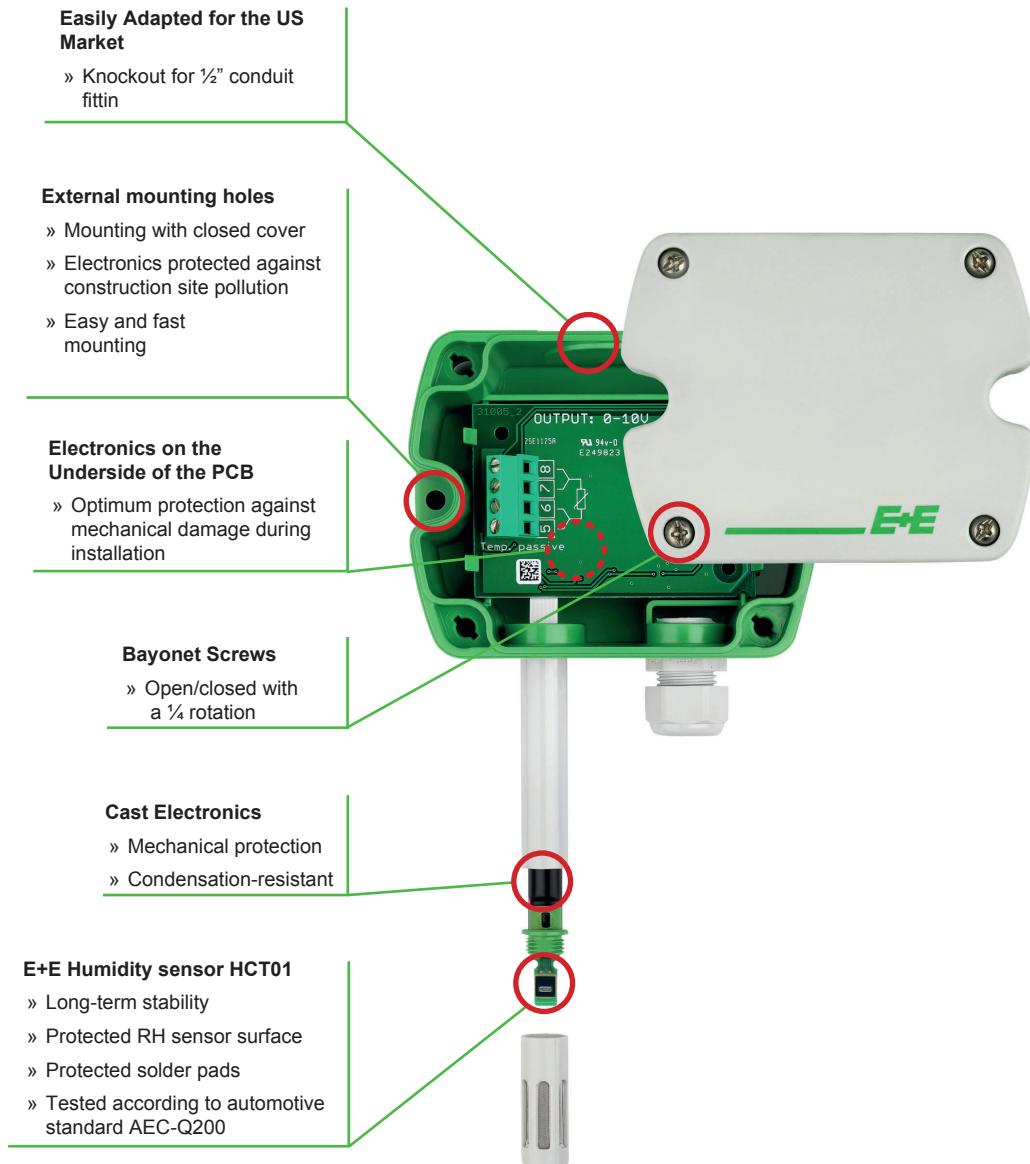

Technical data

Measured values

Relative Humidity

Sensor	E+E Sensor HCT01-00D	
Analog output 0...100% RH	0-10 V	-1 mA < I _L < 1 mA oder
	4-20 mA (two-wire)	R _L < 500 Ohm

Digital output	RS485
Working range	10...95% RH
Accuracy at 20°C	±2.5% RH
Temperature dependency	typ. ±0.03% RH/°C

Temperature

Sensor	Pt1000 (tolerance class B, DIN EN 60751)
Analog output ¹⁾	0-10 V
	4-20 mA
Digital output	RS485
T-Accuracy at 20°C	±0.3°C
passive T-output	see ordering code

General

Power supply	
for 0 - 10 V / RS485	15 - 35V DC or 24V AC ±20%
for 4 - 20 mA	10V + R _L x 20 mA < U _v < 35V DC

Current consumption

Analog	with DC power supply typ. 5mA
	with AC power supply typ. 13mA _{eff}
Digital	with DC power supply typ. 15mA
	with AC power supply typ. 25mA _{eff}

Connection Screw terminals, max. 1.5 mm²

Housing / protection class Polycarbonate (UL listed) / IP65

Cable gland M16 x 1.5

Sensor protection membrane filter

Electromagnetic compatibility EN61326-1
EN61326-2-3



Temperature ranges Operating temperature: -15...60°C (5...140°F)
Storage temperature: -25...60°C (-13...140°F)

¹⁾ Output scaling see Ordering Guide

Dimensions (mm)

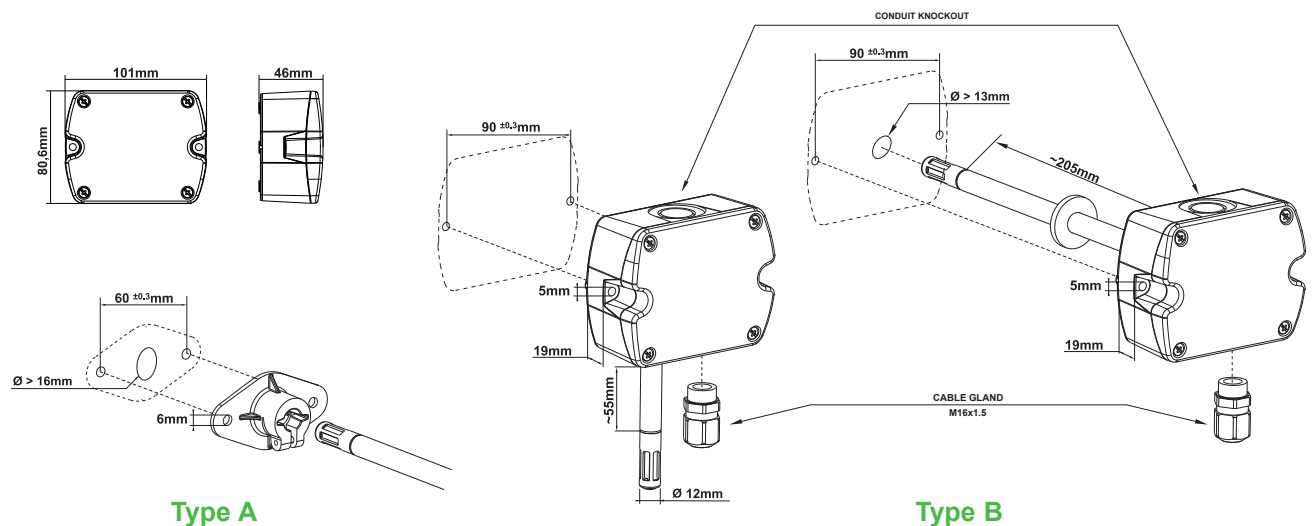

Connection diagram

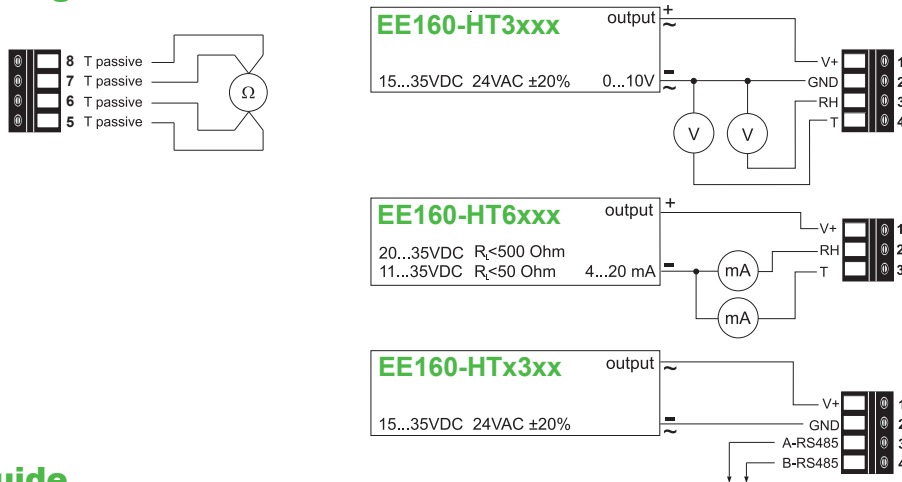

Ordering Guide

Configuratio

Mod EI	ANALo G ¹⁾	dIGITAL ¹⁾	PASSIVE T-SENSo R ²⁾	Ho USING	TYPE	f I L T E R
humidity + temperature (HT)	0-10V (3) 4-20mA (6) none (x)	RS485 (3) none (x)	Pt 100 DIN A (A) Pt 1000 DIN A (C) NTC 10k (E) none (x)	polycarbonate (P)	wall mount (A) duct mount (B)	membrane filter (B)
EE160-						

Interface parameter - analog output

oUTPUT SCAI ING	SCAI ING	UNIT
temperature (Tx)	°C -20...80 (024) -40...60 (002) -10...50 (003) 0...50 (004) other Scalings see Datasheet „T-Scaling“	°F -32...122 (076) -40...140 (083) 0...180 (026)
		metric (M) non-metric (N)

Interface parameter - digital output*

PRo ToCoI	BAUdRATE	PARITY	STo PBITS	UNIT
modbus (1)	9600 (A) 19200 (B) 38400 (C)	odd (o) even (E) no parity (N)	1 stopbit (1) 2 stopbit (2)	metric (M) non-metric (N)

¹⁾a combination of analog and digital version is not possible ²⁾analogue version only

Accessories

Configuration equipment: The configuration equipment allows user setup for the output scaling and for the interface parameters, as well as humidity and temperature adjustment of the sensor.

Position 1:

- configuration adapter (incl. USB cable for PC) (HA011050)

Position 2:

- for EE160 analog: cable for configuration adapter (HA011059)
 - for EE160 digital: cable for configuration adapter (HA011055)

Position 3:

- configuration software: free of charge; download: www.epluse.com/EE160

Position 4 - optional:

- power supply for EE160 (V03)

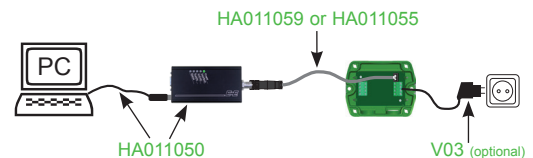

Order example

Analog output

EE160-HT6xAPAB-Tx001M
 Model: humidity + temperature transmitter
 Analog output: 4-20mA
 Passive T-Sensor: Pt 100 DIN A
 Housing: polycarbonate
 Type: wall mounting
 Filter: membrane filter

Output scaling: temperature
 Scaling: -30...40°
 Unit: metric

digital output

EE160-HTx3xPBB-1AE1N
 Model: humidity + temperature transmitter
 Digital output: RS485
 Housing: polycarbonate
 Type: duct mounting
 Filter: membrane filter

Protocol: Modbus
 Baudrate: 9600
 Parity: even
 Stopbits: 1
 Unit: non-metric