

SRD991 Intelligent Positioner with HART, PROFIBUS-PA, FOUNDATION Fieldbus H1 or Without Communication



The intelligent positioner SRD991 is designed to operate pneumatic valve actuators and can be operated from control systems (e.g. the Foxboro I/A Series System), controllers or PC-based configuration- and operational tools such as FDT/DTM Software. The positioner is available with different communication protocols. The multi-lingual full text graphical-LCD in connection with the 3 push buttons allows a comfortable and easy local configuration and operation. For installations in contact with explosive atmospheres, certificates are available.

DEVICE FEATURES

Intelligent

- Auto-start with self-calibration
- Self diagnostics, status- and diagnostic messages
- Easy operation with three key pads
- Multi-Lingual full text graphical LCD
- VALcare™ or Valve Monitor DTM for valve diagnostics and predictive maintenance

With communication

- HART, FOUNDATION Fieldbus H1, PROFIBUS-PA
- Configuration by means of local keys, hand-held terminal (HART), PC with FDT-DTM or I/A Series system

Without communication

- Input signal 4 to 20 mA

COMMON FEATURES

- Stroke 8 to 260 mm (0.3 to 10.2 in) with standard lever; larger stroke with special lever
- Angle range up to 95° (up to 300° as option)
- Supply air pressure up to 6 bar (90 psig), with spool valve up to 7 bar (105 psig)
- Single or double-acting
- Mounting on linear actuators according to NAMUR – IEC 50534-6-1 – VDI/VDE 3847
- Mounting on rotary actuators acc. to VDI/VDE 3845 or IEC60534-6-2
- Protection class IP 66 and NEMA 4X
- Approved for SIL applications
- Explosion protection: Intrinsic safety according to ATEX / IECEx, FM, CSA, INMETRO, NEPSI, EAC, ...

Life Is On

Foxboro.
by Schneider Electric

Contents	Page
• Special Versions of SRD991.....	4
Common technical data for all basic devices ...	5
• Operation, Diagnostics, Service plug.....	6
• Electrical classification	9
Extended technical data for basic devices:	
• With communication HART	10
• With communication PROFIBUS or FOUNDATION Fieldbus.....	11
• Basic device without communication (4-20 mA)	12
Additional equipment for basic devices	13
(built into the basic device)	
• Pressure sensors for premium diagnostics.....	13
One Option board with additional inputs / outputs:	
• 2 Binary inputs or	14
• 2 Binary outputs or.....	15
• 2 Binary in/outputs or	16
• Position feedback and Alarm or.....	17
• Entry for remote Potentiometer.....	18
Additional built-in	
• Limit signal switch	19

Contents	Page
FUNCTIONAL DESIGNATIONS.....	21
MODEL CODES SRD991	22
ACCESSORIES for mounting to the positioner:	
• Booster • Manifolds • Gauge manifolds.....	24
ATTACHMENT to actuators.....	27
DIMENSIONS	31

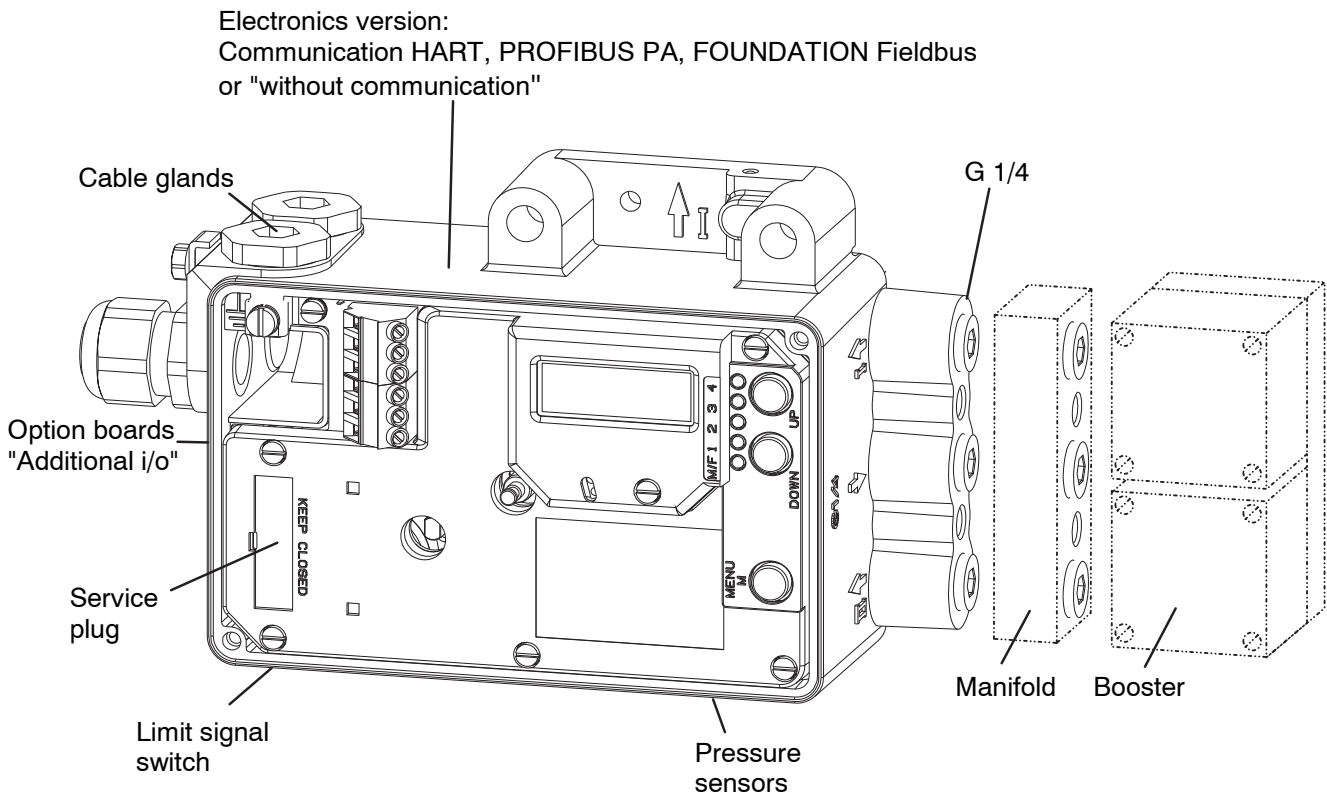

OVERVIEW

The SRD991 consists of a basic device with a digital controller that supports different communication protocols (or also simply 4-20 mA input). Into this basic device, additional equipment can be built such as plug-in cards for electrical input/output signals, position feedback and pressure sensors.

The pneumatic part is available in different versions (single / double acting or spool valve). For very large actuators, boosters with increased air capacity can be flanged on. Also, different manifolds for connection of gauges can be flanged on. For the pneumatic screw connections, we offer different threads in the housing and adapters.

For use in hazardous areas, there are approvals according to ATEX / IECEx, FM, CSA, EAC, NEPSI, etc.

The device can be configured locally by means of push buttons and LCD / LED, or with PC + EDC82 Modem connected to the service plug of the SRD991. By means of communication, the device can be configured remotely via FDT/DTM.

A large variety of attachment kits for all common valves and actuators are available. The list "AttachmentKits.pdf" is updated continuously and can be found on the Internet.

For high temperature or high vibration application, we recommend to mount the SRD991 remotely and not directly on the valve. For this, use the potentiometer unit (like the SRI990 - TXQxxxxx - H).

Please consult TI EVE0105 R for specifications.

To ensure the high performance of the positioner, we offer Advanced Diagnostics and Premium Diagnostics utilities:

	Premium Diagnostics	Advanced Diagnostics
Autostart	Yes	Yes
Custom Characterization	Yes	Yes
Autodiagnostic	Yes	Yes
Alarm Management	Yes	Yes
Alarm Output for Switching (with Optionboard)	Yes	Yes
Status List acc. NE107	Yes	Yes
Position History	Yes	Yes
Response History	Yes	Yes
On Line Friction	Yes	
Stepping Signature	Yes	
Ramping Signature	Yes	
Sensitivity Signature	Yes	
Valve Signature	Yes	
PST (Partial Stroke Test)	Yes	
PST Predictive Maintenance	Yes	

Additional equipment, built into the basic device:

Option Board "2 Binary Inputs" or	B	2 external switches (supplied by SRD) release a control function in the SRD, e.g. "close valve" (configurable)
Option Board "2 Binary Inputs/Outputs" or	E	2 channels, each configurable as an input or output (to be supplied externally)
Option Board "Position Feedback"	F	1 output 4-20 mA (to be supplied externally) gives stroke / angle of rotation; 1 alarm output becomes active with a configurable event
Limit switch	T,U, R,V	Supplies NAMUR signals when exceeding or falling below of two limit values. Inductive sensors, independent of the controller, in normal or safety version or three-wire, or micro switches
	D	Entry for remote potentiometer of external potentiometer unit
Pressure sensors		2 sensors measure the pressure of supply air and output y1 for Premium Diagnostics ; the values are passed on via communication
LCD		Full text graphic LCD in 3 languages

Accessories like Manifolds and Boosters see page 24.

Special Versions of SRD991:

SRD991 Stainless Steel Housing

To be order with model code SRD991-xxxxxxx-Zxxx



Please consult TI EVE0105 INOX for specifications.
For dimensional drawings see page 33.

SRD991 for Top Mounting onto small actuators

This version is designed for direct mounting on top of small actuators without yoke - solution for actuators up to 50 mm stroke.

Instead of the rotary potentiometer, a linear pot is used that feeds back the actual position of the actuator.

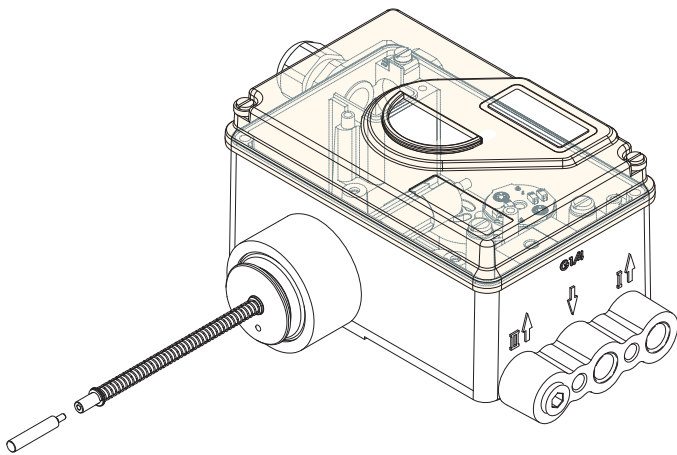

The Model Code of this basic device is
SRD991- -W

The adapter part is dependent on the manufacturer and type of actuator and can be ordered under the code EBZG-TMxx.

Please consult TI EVE0105 TM for specifications.

SRD991 designated for PST (Partial Stroke Test for Emergency Shut Down)

Final control elements in Emergency Shutdown (ESD) applications such as ON-OFF-, Blow Down and Venting valves remain in one position over a long time without any mechanical movement. These valves can show a tendency to get stuck and as a result might not operate upon demand. This can have a severe impact on the functionality of a Safety System and could result in an adverse condition to the operating personnel, plant equipment and the environment. The Partial Stroke Test (PST) offers operators a tool to identify the troubleshooting function of ESD valves. The test can be easily executed via the FDT-DTM based configuration diagnostic tool VALcare™/Valve Monitor.

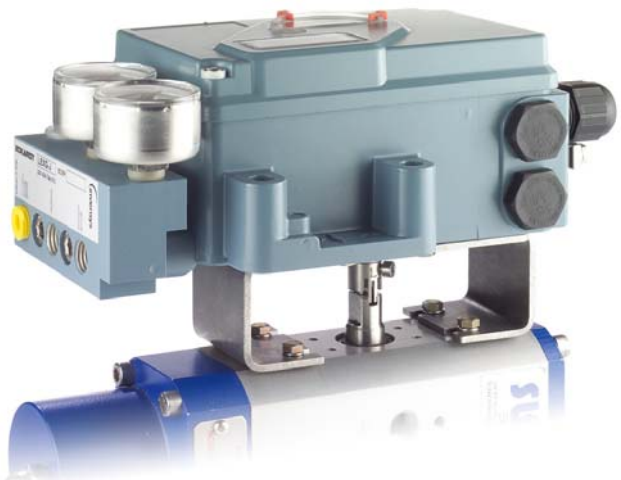

Please consult TI EVE0105 PST.

SRD991 for actuator with rotation up to 300°

This special version of the SRD991 is designed to be mounted by means of standard attachment kit (like the EBZG-R) onto rotary actuator with rotation up to 300°. This special version is made of a standard SRD991 with special gears.

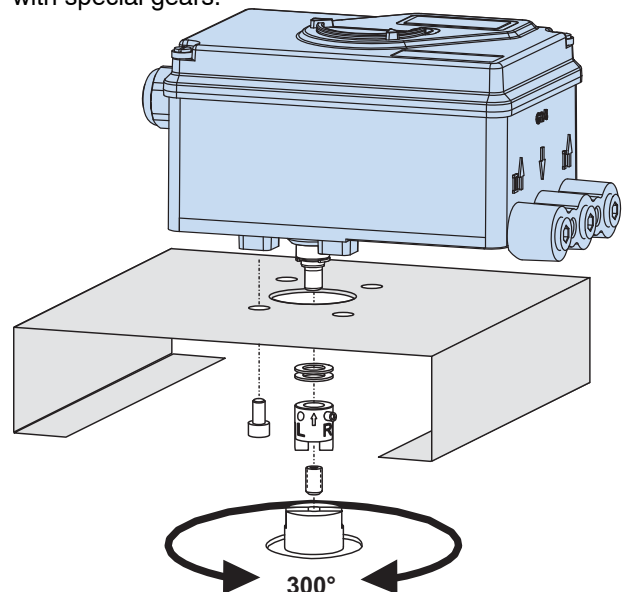

To be ordered under Options -J.
Please consult TI EVE0105 LR.

FUNCTIONAL SPECIFICATIONS (common data for all versions)

Travel range

Stroke range 8 to 260 mm (0.3 to 10.2 in)
 with standard feedback levers; special levers on request
 Rotation angle range up to 95° without mechanical
 stop; up to 300° with Option -J.

Supply

Supply air pressure 1.4 to 6 bar (20 to 90 psig)
 with spool valve ¹⁾ 1.4 to 7 bar (20 to 105 psig)
 Output to actuator 0 to ~100 % of supply air
 pressure (up to 5.5 bar at 6 bar supply air pressure)
 with spool valve heavy duty²⁾: 4 to 10 bar
 Air supply. according to ISO 8573-1
 - Solid particle size and density class 2
 - Oil rate. class 3
 - Pressure dew point 10 K under ambient temperature

The use of filter regulator for air supply of positioner is strongly recommended. It reduces the air pressure to actuator's maximum pressure and keeps it constant.

For supply with Natural Gas instead of compressed air please consult TI EVE0105 G.

Air output I_n/h (scfh)

at max. deviation, single and double acting:

Supply air pressure bar (psig)	1.4 (20)	3 (45)	6 (90)
Standard Amplifier	2 700 (95)	5 000 (177)	7 500 (265)
with Spool Valve ¹⁾	6 000 (211)	12 000 (423)	18 000 (636)

"Heavy duty" spool valve ²⁾ is able to deliver up to 55,000 I_n/h at 10 bar. Please consult TI EVE0105 INOX.

Note: The use of boosters in connection with Spool valve is not recommended.

Air consumption (steady state) I_n/h (scfh)

Supply air pressure bar (psig)	1.4 (20)	3 (45)	6 (90)
single acting	80 (2.8)	130 (4.6)	220 (7.8)
double acting	130 (4.6)	230 (8.1)	430 (15.2)
Spool Valve	100 (3.5)	240 (8.5)	500 (17.7)

Response characteristic ^{3) 4)}

Sensitivity < 0.1 % of travel span
 Non-linearity (terminal based adjustment) < 0.4 % of travel span
 Hysteresis < 0.3 % of travel span
 Supply air dependence. < 0.1 % / 1 bar (15 psi)
 Temperature effect. < 0.3 % / 10 K
 Mechanical vibration
 10 to 60 Hz up to 0.14 mm,
 60 to 500 Hz up to 2 g < 0.25 % of travel span

Volume Booster Series (to order as accessory)

For large actuators or to reduce action time, a volume booster may be necessary.

VBS100 / VBS110

Volume boosters with Cv1 and pneumatic connection 1/4", for remote mounting
 VBS100 in Aluminium, VBS110 in Stainless Steel 316

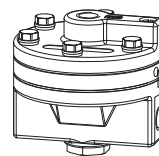

For more information please consult PSS EVE0601.

VBS200 / VBS201 / VBS202

Volume booster with Cv 2 and pneumatic connection 1/2", for direct side mounting to positioner, remote mounting, or mounting acc. to VDI/VDE 3845

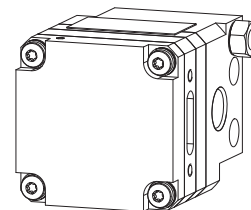

For more information please consult PSS EVE0602.

VBS300 / VBS310

Volume boosters with Cv7 and pneumatic connection 1", for remote mounting
 VBS300 in Aluminum, VBS310 in Stainless Steel 316

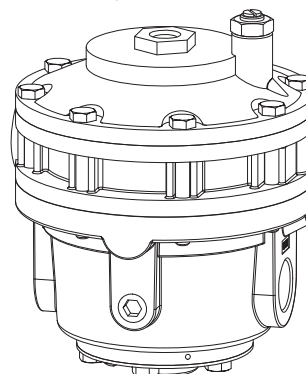

For more information please consult PSS EVE0603.

1) Spool valve is the type of amplifier used in device SRD991-Cxxxx-S
 2) Spool valve heavy duty is the amplifier used in stainless steel version SRD991 - Cxx... - SZK
 3) Data measured according to VDI/VDE 2177
 4) With stroke 30 mm and lever length 90mm

FUNCTIONAL SPECIFICATIONS (common data for all versions)

Features

Automatic start-up (Autostart functionality)

Automatic determination of the mechanical end positions of the valve (initial value and final value), IP motor parameters, direction of action of the spring and control parameters.

The control parameters are optimized dynamically during this routine.

This procedure makes a perfect adjustment and optimization to the actuator possible without additional manual settings! Several autostart modes are available (details see on next page).

Options

- Built-in independent inductive limit switches
- Pressure sensors for monitoring of air supply and output pressure I (y1)
- Additional inputs / outputs:
 - Position feedback 4-20 mA + binary alarm output, to be supplied external
 - 2 binary outputs (position alarms)
 - 2 binary inputs, to be supplied external
 - 2 contact inputs, internal supplied
 - 2 binary in-/outputs, to be supplied external

Operation and Configuration

The local LCD enable a fast and easy configuration as well as diagnostic.

Local with local key pads
 Display Multi-lingual Graphic LCD, some versions with 5 LEDs

The positioner in the version with LCD contains three different menu languages. Standard menu languages:

- English
- German

Freely selectable third language:

- French - Portuguese - Spanish
- Italian - Swedish - ...

(further menu languages see Model Code page 23).

The third menu language has to be selected and specified with the order, otherwise standard: French.

The third, freely selectable menu language can be modified to another language by means of the VALcare™ DTM. ²⁾

The additional languages can be downloaded from our homepage.

Diagnostics

– in the field:

- Status and Diagnostic messages via LCD

– via VALcare™ or Valve Monitor DTM ⁴⁾:

- Service Management for planning and scheduling of service intervals
- Histograms for displaying the position- and response-history over time
- Partial Stroke Test for the functional inspection of safety related actuators
- Hours in operation, cycle counter and travel sum of the actuator are determined
- Surveillance of loop current

- Shows condition of device:
 - Potentiometer
 - IP Motor
 - Exceeding range of actuator (possible indication for wear of plug or seat)
 - Remaining control deviation (possible indication for jammed actuator, blocked valve stem or plug, insufficient air capacity /supply air pressure /positioning pressure)
- If equipped with pressure sensors (optional, see page 3):
 - Monitoring of the stem friction
 - Histograms for displaying the friction-history over time
 - Surveillance of air supply and output pressure, each with display of physical value
- Additional diagnostical possibilities in control operation by means of external sensors (optional).
 See also the VALcare™ Documentation.

Service plug

All basic devices are equipped with a service plug **A** at the front side. There via RS232 interface a PC with VALcare (DTM) can be connected via modem EDC82 (galv. separated, not Ex).

Information about EDC82 modem see TI EVE0102 Y.

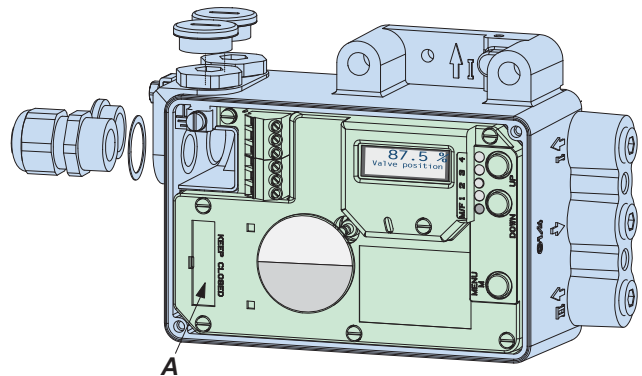

2) With the versions "Intelligent without communication" this is only possible with modem EDC82

3) By means of "Additional inputs / outputs"

4) For the SRD991 without communication the use of the service plug is necessary to have access at the diagnostic with DTM

Manual local and remote settings:

Actuator mode	linear or rotary actuator
Linear valve	left or right mounted
Rotary actuator	opening clockwise or counter-clockwise
Characteristic of setpoint	linear, equal percentage, invers-equal percentage or custom (22 points)
Valve function	opens or closes with increasing setpoint
Split range	free upper and lower values
Travel limits	free upper and lower values
Cutoffs	free upper and lower values
Stroke range	configurable
Temperature unit	configurable (°C or °F)
Autostart	- Endpoints - Standard Autostart - Enhanced Autostart - Smooth response - Fast response
Control parameters	Determined during Autostart.
Working range	freely adjustable (for indication on LCD)
Manual adjustment of	P-gain, I-time, T63-time and dead band
Manual operation	Manual input of setpoint to drive the valve in steps of 12.5 %, or 1 %
Pneumatic test	Function to test the pneumatic output
Workshop	input and angle calibration
LCD language	dependent on version
LCD orientation	dependent on version
PROFIBUS-PA	Bus address
FOUNDATION Fieldbus	Simulation Switch from Link Master to Basic Field Device

Software supported configurations:

- By means of Hand Held Terminal (HART)
- PC by means of VALcare Software
- I/A Series System, Foxboro Evo and other DCSs

Failure handling

In case of Single Acting, Safety position at

- Air supply failure pressure y1 = zero
- Electric power failure pressure y1 = zero
- Failure of electronics pressure y1 = zero

In case of Double Acting or spool valve amplifier, safety position at

- Air supply failure pressure y1 = zero / y2 = zero
- Electric power failure pressure y1 = zero / y2 = full air supply pressure
- Failure of electronics pressure y1 = zero / y2 = full air supply pressure

For all types of amplifiers (with FF H1 or Profibus PA)

- Failure of communication is recognized by configurable watch dog with response delay of 0.1 s to 24 h

Behavior configurable as

- pressure y1 = zero or
- stop at last value or
- a configured value

Diagnostic report via communication and local LCD

- Historical status is set if alarm was activated at any time (also just short alarms)

Reset by acknowledging

Spool Valve Amplifier for single and double acting application

Spool valve amplifier as option for the SRD991 can be used with double acting actuator and also with single acting actuator.

In case of single acting application, one of the pneumatic output must be closed:

- If y1 is used, y2 is closed and failure handling for Electric power failure and Failure of electronics becomes y1=zero.
- If y2 is used, y1 is closed and failure handling for Electric power failure and Failure of electronics becomes y2=full air supply.

FUNCTIONAL SPECIFICATIONS (common data for all version)

Mounting

Attachment to stroke actuators

- direct, FlowPak/FlowTop . . . with attachment kit EBZG –E
- for casting yoke
acc. to IEC 534-6 (NAMUR) with attachment kit EBZG –H
or –H1
- for pillar yoke
acc. to IEC 534-6 (NAMUR) with attachment kit EBZG –K
or –K1

Stroke range with feedback lever:

- standard (EBZG-A) 8 to 70 mm / 0.31 to 2.76 in
 - extended (EBZG-B) 60 to 120 mm / 2.36 to 4.72 in
 - extended (EBZG-A1) 110 to 260 mm / 4.33 to 10.24 in
- Larger stroke ranges can be realised with special levers.

Attachment to rotary actuators

acc. to VDI/VDE 3845 ...

- with attachment kit EBZG -R
- Further attachment kits see ModelCodes page 26
- Mounting orientation see attachment dimensions starting from page 27

Materials

- Housing and covers Aluminum (Alloy No. 230)
finished with DD-varnish
- All moving parts of
feedback system 1.4306 / 1.4571 / 1.4104
- Attachment kits V4A or Aluminum, finished
with DD varnish
(depending upon version) . . (Alloy No. 230)
- Mounting bracket Aluminum (Alloy No. 230)
- Pneumatic diaphragms PVMQ (Silicone elastomer
suitable for use in the paint
industry)

Weight

- Single acting approx. 1.7 kg (3.7 lbs)
- Double acting approx. 2.0 kg (4.4 lbs)

Pneumatic connection

- NAMUR mounting G 1/4 for pipe diameter 6 to
12 mm (0.24 to 0.47 in) for air supply and outputs y1, y2
to the actuator; 1/4-18NPT with additional connection
manifold
- Direct mounting Instead of the output y1, an
air connection on the back with O-ring will be used
(closed at NAMUR mounting).

Electrical Connection

- Line entry 1 or 2 cable glands 1/2-14 NPT
or M20 x1.5 (others with Adapter AD-...)
- Cable diameter 6 to 12 mm (0.24 to 0.47 in)
- Screw terminals 2 terminals for input,
4 terminals for additional inputs / outputs;
Tightening torque min. 0.5 Nm, max. 0.6 Nm
- Wire cross section solid wire 0.5 to 6 mm²
stranded wire 0.5 to 4 mm²
crimped wire 0.5 to 2.5 mm² (AWG 21-14)
- Test sockets integrated in terminals, for
options and communicator
connection

Ambient conditions

- Operating conditions acc. to IEC 654-1
- The device can be operated at a class Dx location
- Ambient temperature
Operation ¹⁾ –40 to 80 °C (–40 to 176 °F)
Transport and storage –40 to 80 °C (–40 to 176 °F)
- If the device is exposed to sunlight and the temperature may rise
above 80 °C, we recommend a sun shade.
- Storage conditions
acc. to IEC 60721-3-1: . . . 1K5; 1B1; 1C2; 1S3; 1M2
- Indicators
LCD (visible) ²⁾ –25 to 70 °C (–13 to 176 °F)
LEDs (if present) –40 to 80 °C (–40 to 176 °F)
- Relative humidity up to 100 %
- Protection class ³⁾
acc. to IEC 60529 IP 66
acc. to NEMA Type 4X

Electromagnetic compatibility EMC

- Operating conditions industrial environment
- Immunity according to
EN 61326 fulfilled
IEC 61326 fulfilled
EN 61000-6-2 fulfilled
- Emission according to
EN 61326
Class A and Class B fulfilled
EN 61000-6-4 fulfilled
EN 55011 Group 1,
Class A and Class B fulfilled
NAMUR recommendation
EMV NE21 fulfilled

SAFETY REQUIREMENTS

CE label

- Electromagnetic
Compatibility ⁴⁾ 2004/108/EC
- Low-voltage regulation not applicable

Safety

- According to EN 61010-1
(or IEC 61010-1) Safety class III
Overvoltage Category I
- Internal fuses only with PROFIBUS or
FOUNDATION Fieldbus,
but not replaceable
- External fuses Limitation of power supplies
for fire protection must be observed acc. to EN 61010-1,
appendix F (or IEC 61010-1).

- 1) Details see Certificates of Conformity.
With Limit Switches Code T only –20 °C.
With Limit Switches Code R only –25 to 70 °C
- 2) Below –20 °C the LCD reacts only slowly; above 70 °C the background
becomes dark
- 3) Under service as directed
- 4) With PROFIBUS or FOUNDATION Fieldbus only, if shield of wiring is
grounded on both sides
- 5) Pneumatic connection 1/4-18 NPT made with a separate manifold
delivered together with the device

Electrical classification ^{1) 2)}

See Certificates of Conformity EX EVE0105 A

Type of protection "Intrinsically Safe"**ATEX / IECEx**

Marking Ex ia IIC T4 Gb,

Ex ia IIC T6 Gb

Temperature classes

Version with HART communication and "without communication":

T4 with explosion protection code EA4

Version with communications HART, FOUNDATION Fieldbus and PROFIBUS-PA:

T4 / T6 with explosion protection code EAA

Certificate of Conformity IECEx EPS 16.0034

EPS 16 ATEX 1 083

For use in hazardous areas in circuits certified as intrinsically safe with the following maximum values:

Profibus / Fieldbus		HART	
Ui	24 V DC	Ui	30 V DC
li	380 mA	li	130 mA
Pi	5.32 W	Pi	0.9 W
Ci	1.3 nF	Ci	1.3 nF
Li	5 μ H	Li	5 μ H

Ci: effective inner capacity

Li: effective inner inductivity

The supply connections have an inner capacity of max. 5.3 nF opposite the ground.

Ambient temperature ranges:

Temperature class T4: -40 °C to 80 °C

Temperature class T6: -40 °C to 55 °C

Explosion protection Zone 2 / 22

Installation of the SRD991 in potentially explosive atmospheres for Zone 2 / 22 (explosion protection II 3 G/D Ex ic Gc/Dc)

The Intelligent Positioner SRD991 in protection level intrinsic safety "ic" (II 3 G/D Ex ic Gc/Dc) can also be operated in potentially hazardous areas of Zone 2 / 22.

Explosion protection Zone 20

EX II 1D Ex ia IIIC T 100°C Da. . . . -40 °C < T_a < 100 °C

Electrical Data

Supply circuit in type of protection Intrinsic safety Ex ia.

The positioner type SRD991 fulfils the requirements of explosion protection for the Equipment Group II and Category 1D in type of protection Intrinsic safety for dust with a maximum surface temperature of 100 °C.

FM Type of protection

IS / I,II,III / 1 / ABCDFG / T4 Ta = 80°C, T6 Ta = 55 °C

Entity; Type 4X; DOKZ 534 396 049

NI / I / 2 / ABCD; S / II,III / 2 / FG / T4 Ta = 80 °C, T6 Ta = 55 °C; Type 4X

CSA

PROCESS CONTROL EQUIPMENT-Intrinsically Safe, Entity - For Hazardous Locations

Class I, Groups, A, B, C and D; Class II, Groups E, F and G; Class III:

Ex ia IIC T4/T6 IP65:

- SRD 991 HART/4-20mA/FOXC0M/Profibus/Fieldbus-abcdefgh-j Positioner: 12-36 V dc, 4-20 mA or < 48 V dc, Intrinsically safe when installed as per submittor's Dwg DOKZ 534 396 067 or DOKZ 534 396 076; Temp. Code T4 at Max Amb. 80C or T6 at Max Amb. 55C.

Note: Model No is followed by suffix abcdefgh-j denoting minor mechanical differences and options not affecting safety.

With Electrical Classification ATEX + Zone 20 Dust, Codes ED4 and EDA, the Travel indicator is not visible.

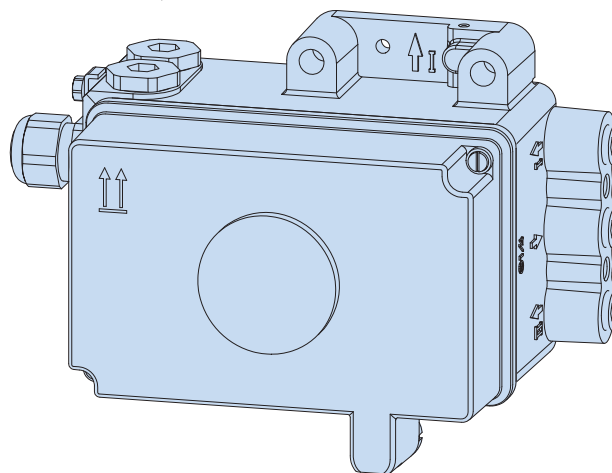

- 1) With appropriate order only
- 2) National requirements must be observed
- 3) Standard has been replaced by a new standard or revision. The products are according to these new standards or revisions, because the modified requirements are not relevant.

SRD991 with HART communication
SRD991-xHxxxx

- Signal Input Two wire system
- Reverse polarity protection . . standard feature
- Signal range 4-20 mA
- Operating range 3.6 to 21.5 mA
- Input voltage DC 12 to 36 V ¹⁾ (unloaded)
- Load 420 Ohms, 8.4 V at 20 mA
- Communication signal HART, 1200 Baud, FSK
 (Frequency Shift Key)
 modulated on 4-20 mA
 0.5 Vpp at 1 kOhm load
- Input impedance Zi. Z = 320 Ohms
 for ac voltage 0.5 to 10 kHz with < 3 dB non-linearity
- Cable capacity and inductance see HART standard
 specifications (e.g. C < 100 nF).
- Impedance of other devices at the input (parallel or serial)
 must be within HART spec.
- Applications without communication require not to exceed
 input capacitance parallel to the input not higher than 100 µF.
- Start-up time approx. 3 sec
- Interruption time without power down:
 with LCD typ. 80 ms ²⁾

1) On request we can specify higher voltage limits
 2) Worst case conditions 4-20 mA, with position feedback option, i/p-output with max. current

Configuration

The SRD991 can be configured via HART by any host system whatever is a PC with a HART Modem, Hand Held Terminal or a DCS.

LOCAL (by means of local key pad and LCD display)
 See page 6

DTM (Device Type Manager)

We are a leading company in term of FDT-DTM technology
http://www.fdtgroup.org/product-catalog/certified-dtms?company=Foxboro+Eckardt+GmbH&field_device_type_value_many_to_one=All&field_protocol_value_many_to_one=All

Therefore we provide a DTM fully certified for its inter-operability and with the state-of-the-art presentation and diagnostics features.
 The DTM can be downloaded from our homepage.

DD (Device Description) and EDD (Enhanced Device Description)

In case the host system is not supporting the FDT-DTM technology, you can download the DD and/or EDD from our homepage.

SRD991 with communication PROFIBUS-PA and FOUNDATION Fieldbus H1 SRD991-xPxxxx or SRD991-xQxxxx

PROFIBUS-PA

Data transfer according to PROFIBUS- PA
profile class B based on EN
50170 and DIN 19245 part 4

GSD file the actual file can be down-
loaded from our homepage

Configuration

Local / Display see page 6

Software VALcare™ -DTM

Hardware PC- or PCMCIA- interfaces
from Softing

I/A Series System FBM 223 in combination with
CP60

Other control systems All Profibus-PA- compatible,
e.g. Siemens SIMATIC PDM
(Process Device Manager)

FOUNDATION Fieldbus H1

Data transfer FF Specification Rev. 1.4,
Link-Master (LAS)

Two revisions of Firmware can be selected for the
FOUNDATION Fieldbus devices in the model code of the
positioner. The selection of the Firmware revision is
depending of the DCS compatibility, the DD Files already
installed in the DCS and the installed base on your site.

Double check interoperability of following characteristics
with your DCS before ordering!

When selected **Firmware FF16** in the model code :

Certified according to ITK 4.6

Function Blocks PID, AO, 2xDI, 1xDO
Transducer, Resource

When selected **Firmware FF18** in the model code :

Certified according to ITK 6.0.1

Function Blocks PID, AO, 4xDI, 1xDO, IS, OS,
AI, MAI, Transducer,
Resource

Additional functionality . . . Flat Addressing

DD files the actual file can be down-
loaded from our homepage

Configuration

Local / Display see page 6

Software VALcare™ -DTM
or National Instruments
NI-FBUS configurator

Hardware FBUS-interfaces from National
Instruments (AT-FBUS and
PCMCIA- FBUS)

I/A Series System FBM220 or FBM221 in
combination with CP60

Other control systems All FOUNDATION Fieldbus
H1- compatible, e.g. SMAR, Fisher Rosemount Delta-V,
Honeywell, Yokogawa, ABB

For both fieldbus devices

Input signal digital

Supply voltage DC 9 to 32 V ¹⁾

max. Supply voltage DC 36 V

Operating current 10.5 mA ± 0.5 mA (base current)

Current amplitude ± 8 mA

Fault current. Base current + 0 mA
(base current + 4 mA by means of independent
FDE-safety circuit) according to IEC 1158-2

Operating values according to IEC 1158-2

Start-up time (init phase) . . . approx. 2 sec

Bus connection Fieldbus interface based on
IEC 1158-2 according to FISCO-Model

Power supply Power supply is achieved
dependant on the application by means of fieldbus
power supply units or segment coupler

Electrical classification thereto

see page 9

SRD991 without communication SRD991-xDxxxx

Signal Input Two wire system

Reverse polarity protection . . Standard feature

Signal range 4-20 mA

Operating range 3.6 to 21.5 mA

Input voltage DC 8.5 to 36 V ²⁾ (unloaded)

Load 300 Ohms, 6 V at 20 mA

With applications without communication the capacity
parallel to input may not be higher than 100 µF.

Start-up time approx. 3 sec

Interruption time without power down:
with LCD typ. 80 ms ³⁾

Configuration

Local / Display see page 6

Software VALcare™ (DTM)

Hardware per modem EDC82

Electrical classification thereto

see Page 9

1) Data of "Intrinsically Safe" version

2) On request we can specify higher voltage limits

3) Worst case conditions 4-20 mA, with position feedback option, i/p-output
with max. current

OVERVIEW ADDITIONAL EQUIPMENT

(built into any basic device)

Built-in Pressure sensors for Premium Diagnostic, Code Option –B

For supply air and output y1 to actuator
 Measuring range 0 to 8 bar (0 to 120 psig)
 Accuracy 2 %
 Temperature influence 0.5 % / 10 K (–40 to 80 °C)

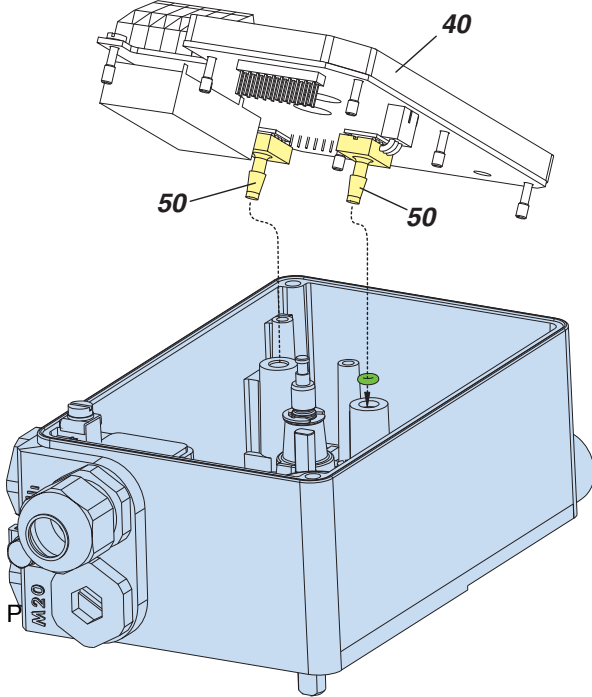

Additional Inputs / Outputs:

One module “Additional inputs / outputs” **8** can be plugged onto main electronics **40** :

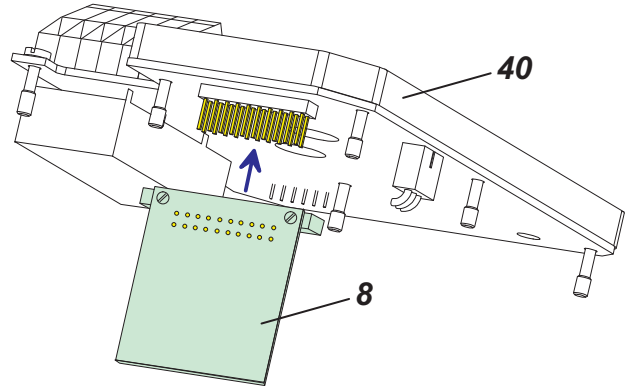

- 2 Binary inputs or
 - 2 Binary in/outputs or
 - Position feedback and Alarm
- Details see following pages.

Built-in Limit Switch

Details see page 19

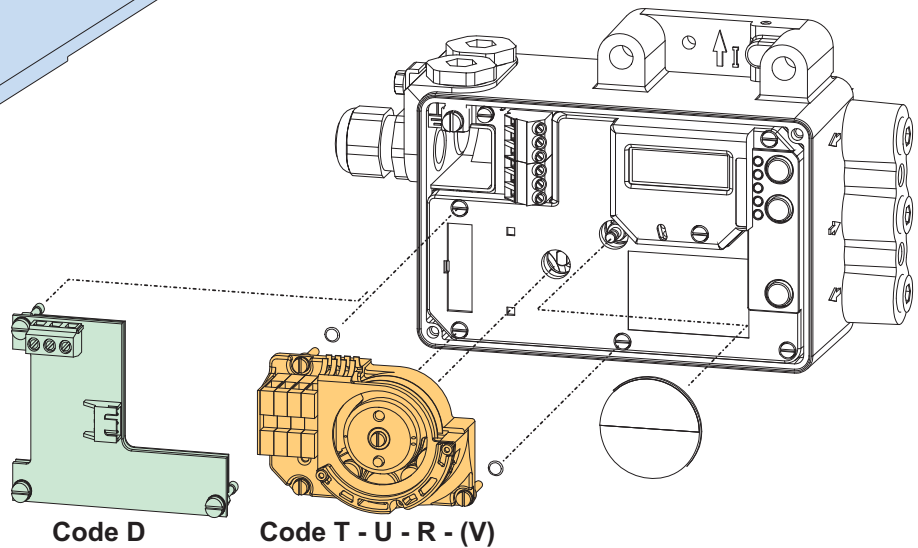

Parts Kits for additional installation of auxiliary functions

Model codes, Additional inputs / outputs	Supply	Parts Kit
Code B: 2 Binary inputs (Contact inputs)	internal	EW 411 407 325
Code E: 2 Binary in/outputs	external	EW 411 407 956
Code F: Position feedback 4-20 mA and Alarm (ATEX)	external	EW 426 434 228
Model codes, Limit signal switches		
Code T: Limit signal switch, normal version	external	EW 426 164 012
Code U: Limit signal switch, security version	external	EW 426 164 021
Code R: Limit signal switch, 3-wire	external	EW 426 164 057
Code V: Limit signal switch, micro switches	external	EW 426 164 066
Code D: Entry for remote potentiometer	internal	EW 426 164 093

Entry for remote potentiometer
(for remote mounting main unit)

– Code D

This remote application is used in applications where high temperatures or vibration are present and can result in negative influences to the control. It can also be used in places not easy to reach, to ensure an easier handling of the unit, or for cylinders with large strokes.

The Positioner SRD991 (Remote unit) is mounted far away from the valve or cylinder in a safe environment.

The Potentiometer unit is mounted on the valve or cylinder. This potentiometer unit can be made of a derivative version of the SRI990 positioner (only potentiometer in the housing) or of an external potentiometer like a linear potentiometer for application onto cylinders, for example.

This option is to be used with a potentiometer unit 3 wires system with approx. 5 kOhm resistance.

If the following requirements are observed, the set-up is insensitive to electrical disturbances caused by high electromagnetic fields, EMC and HF-radiation.

Cable Length max. 10 m (32 ft)

Cable Specification (not supplied by us):

- 3-wire twisted pair, shielded
- Shield needs to be connected on both ends to the internal ground
- Shield endings need to be kept very short when connecting to the ground
- A HF cable gland is not required

For more information about remote mounting please consult TI EVE0105 R.

Note: The functionality and certifications are only ensured with our 5 kOhm potentiometer.

Electrical Classification ATEX / IECEx:

Types of protection and temperature classes as basic device, see page 9.

Additions for this option in EC-Certificate of Conformity IECEx EPS 16.0034 and EPS 16 ATEX 1 083:

For use in hazardous areas in circuits certified as Intrinsically Safe with the following maximum values:

- U_{max} = 6.5 V
- I_{supply} = 25 mA
- I_{wiper} ≤ 1 mA
- P_{total} ≤ 40 mW

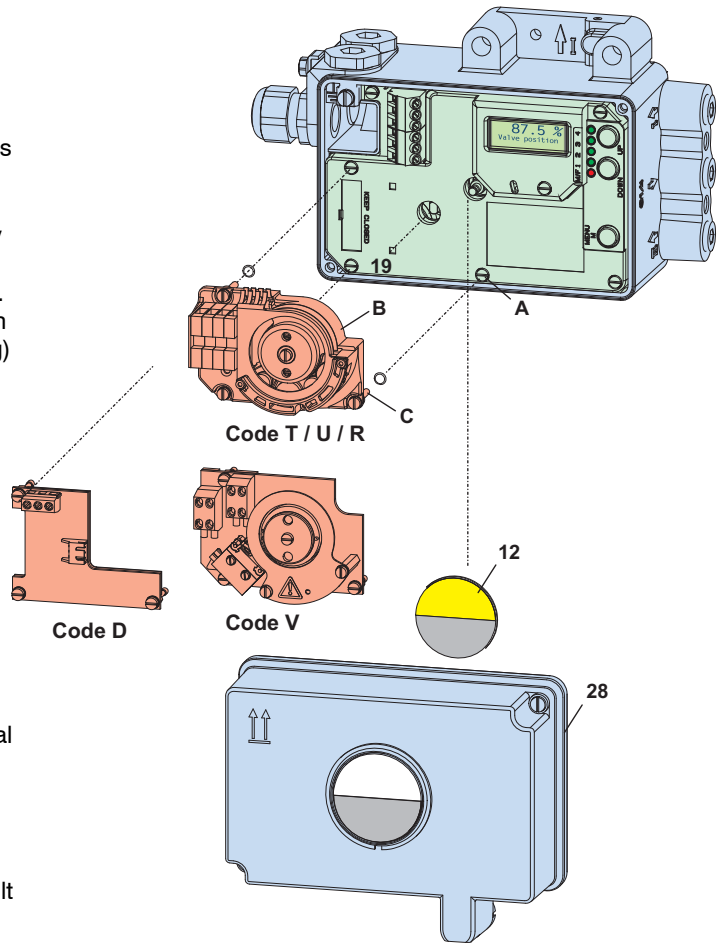

Built-in Limit Switches

- Stroke / angle derived from positioner feedback
- Standard version (SJ2-N)Code T (only to -20°C)
 - Security version (SJ2-SN)Code U
 - 3-wire (SI2-K08-AP7/ PNP)Code R (no Ex, -25 to 70 °C)
 - Micro switches (V4NS)Code V (no Ex)
 - Entry for remote potentiometer Code D

Materials

- Control vanes Aluminum
- Transmission shaft 1.4571

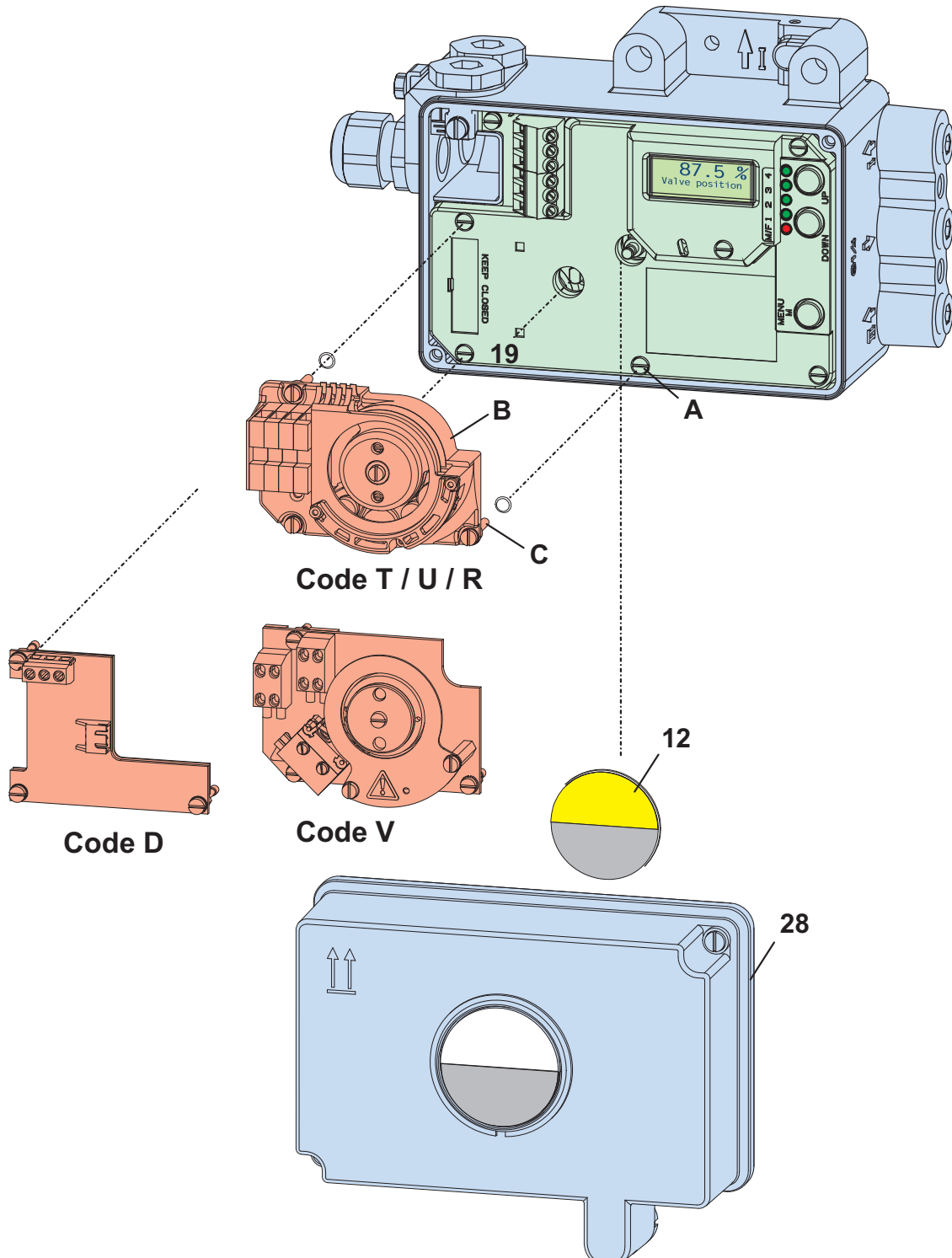

Inductive Limit Switch (Code T, U)

Output 2 inductive proximity sensors
 acc. to DIN 19 234 or NAMUR for connection to switching
 amplifier ¹⁾

Current consumption
 Vane clear > 2.2 mA
 Vane interposed < 1 mA

for control circuit with the following electrical values:
 Supply voltage DC 8 V, R_i approx. 1 kOhm
 Supply voltage range. DC 5 to 25 V (with "no Ex")
 Residual ripple < 10 % p.p.
 Permissible
 line resistance < 100 Ohms

Response characteristic ^{2) 3)}
 Switching differential < 1 %
 Switching point repeatability < 0.2 %

Terminals for GW1 41+, 42–
 GW2 51+, 52–

**Electrical Classification ATEX / IECEx
 of versions "T" and "U":**

Types of protection and temperature classes as basic device,
 see page 9.

Additions for this option in EC-Certificate of Conformity
 IECEx EPS 16.0034 and EPS 16 ATEX 1 083:

For use in hazardous areas in circuits certified as Intrinsically
 Safe with the following maximum values:

U_i= 16 V, I_i= 25 mA, P_i= 64 mW

Internal capacitance and inductance: C_i= 30 nF, L_i= 100 μH

The electric circuits of "Built-in Limit Switch" are galvanically
 separated from all other circuits and from earth.

Inductive Limit Switch, three-wire system

– Code R

Input Stroke / angle from actuator
 via positioner feedback lever

Output 2 inductive proximity sensors,
 three-wire system,
 LED indication, contact, pnp ²⁾

Supply voltage U_s DC 10 to 30 V
 Residual ripple ± 10 %, U_s = 30 V
 Switching frequency 2 kHz
 Constant current 100 mA

Response characteristic ⁶⁾
 Gain continuously adjustable
 from 1:1 to approx. 7:1

Switching differential < 1 %
 Switching point
 repeatability. < 0.2 %

Terminals for GW1 42
 GW2 52
 Supply. 41+, 43–

Mechanical Switches (Micro Switches) Code V
 (only without Ex protection)

Stroke / angle derived from positioner feedback lever

Output 2 mechanical switches
 (Micro switches) ^{5) 6)}

Manufacturer Saia-Burgess

Type V4NS-C4-AC1-UL
 (UL- and CSA-approved)

Parts set for subsequent mounting:

Code V EW 426 164 066

Absolute limit values AC

of mechanical switches built into positioner:

U_{max}. 130 V AC ⁷⁾

I_{max} 0.5 A (resistive Load) ⁷⁾

I_{max} 0.03 A (inductive Load) ⁸⁾

Absolute limit values DC

of mechanical switches built into positioner: ⁹⁾

U_{max}. 30 V

DC I_{max} 1 A

Switching Differential: < 2.5 %

Terminals for SW1 41, 42

SW2 51, 52

The circuit of the mechanical switches have to be protected
 by a suitable fuse. The diameter of the protective conductor
 needs to be at least 1.5 mm² / AWG 16.

1) Operating mode min. (= low) / max. (= high)
 selectable by adjustment of switch vanes

2) Data measured according to VDI/VDE 2177

3) With stroke 30 mm and lever length 90 mm

5) Operating mode min. (=low) / max. (=high) selectable by adjusting the
 respective vane

6) Operating mode normally open / normally closed selectable by vane
 adjustment

7) Approval according to UL (UL 1054) and CSA (CSA 22.2 No. 55) at
 6,000 operations and T = 65 °C / 149 °F

8) Based on EN 61058-1, at 10,000 operations and T = 85 °C / 185 °F

9) General rating at 50,000 operations and T = 85 °C / 185

FUNCTIONAL DESIGNATIONS

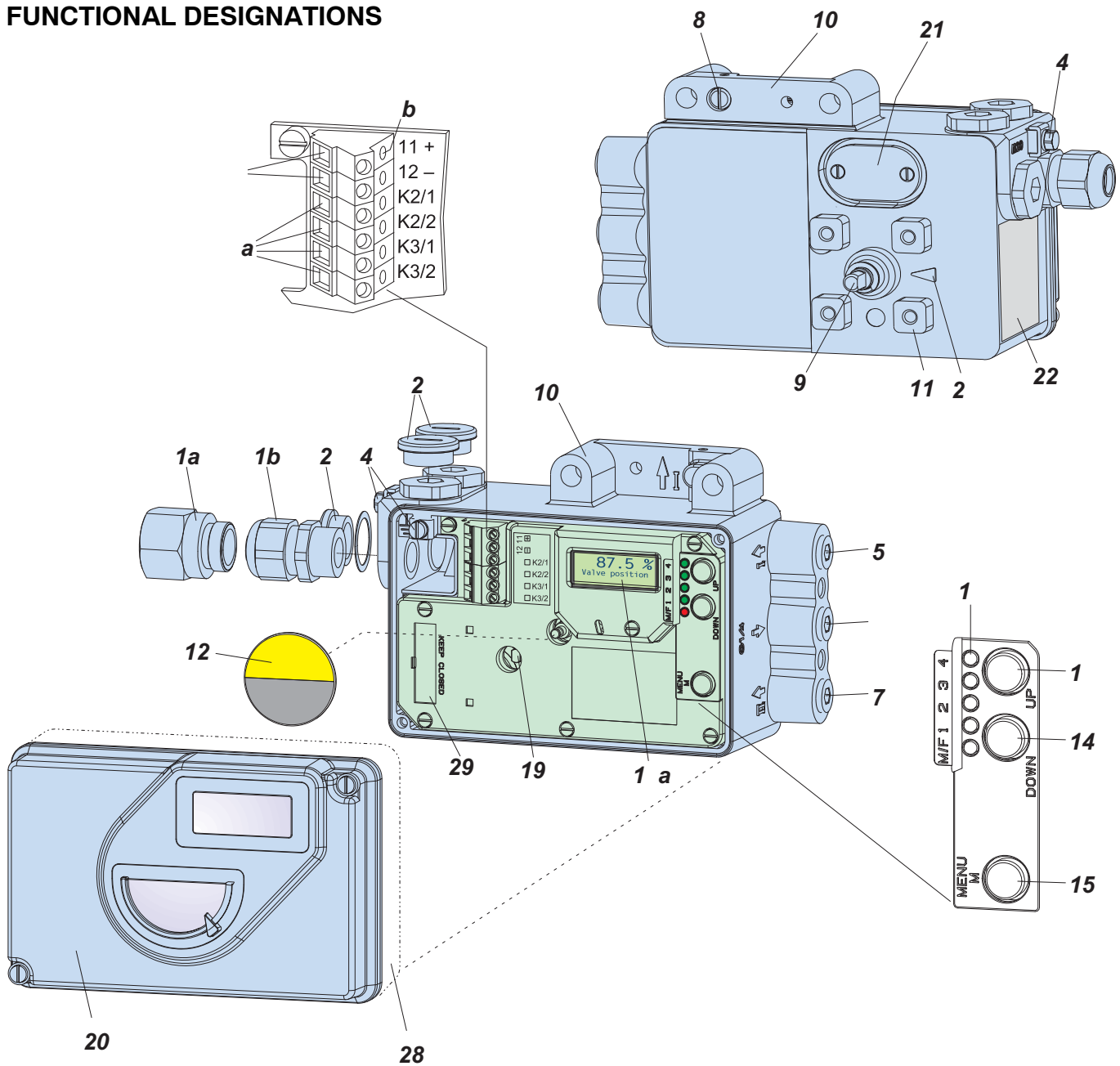

1a Adapter, eg. 1/2"-14 NPT

1b Cable gland

2 Plug, interchangeable with Pos.1

3 Screw terminals ¹⁾ (11 / 12) for input (w)
or for bus connection IEC 1158-2

3a Screw terminals ¹⁾ for additional inputs / outputs

3b Test sockets Ø 2 mm, integrated in terminal block

4 Ground connection

5 Female thread ^{G)} 1/4 -18 NPT or output I (y1)

6 Female thread ^{G)} 1/4 -18 NPT for air supply (s)

7 Female thread ^{G)} 1/4 -18 NPT or output II (y2)

8 Direct attachment hole for output I (y1)

9 Feedback shaft

10 Connection manifold for attachment to stroke actuators
(not with VDI/VDE 3847 version)

11 Connection base for attachment to rotary actuators

12 Travel indicator

13 Key **UP**

14 Key **DOWN**

15 Key **M** (Menu)

16 Status display (1 red LED, 4 green LEDs)²⁾

16a LCD with true text in 3 different languages

19 Fixing shaft for limit switch

20 Cover with window to **12**

21 Air vent, dust and water protected

22 Data label

26 Arrow is perpendicular to shaft **9** at angle 0 degree

27 Ball valve for protection class NEMA 4X

28 High cover with built-in limit switch

29 Plug for service connector ³⁾

G) With marked letter "G" in the housing the pneumatic connecting threads are cut as G 1/4 instead of 1/4-18 NPT

1) Alternatively Cage clamps (WAGO) instead of screw terminals

2) Depending on the version, the device is equipped with or without LEDs

MODEL CODES SRD991 (continued)

OPTIONS

Premium Diagnostics Features (made with built-in Pressure Sensors) ..(v)	-B
Positioner free of copper and its alloys	-C
Pneumatic Amplifier in the "Spool Valve" Version.....	-S
Approved for SIL2 / SIL3 application.....	-Q
Custom Configuration.....	-T
Version of Positioner according to VDI/VDE 3847	-N
Version for ESD Valve with PST functionalities	-E
Rotating angle up to 300 °	-J
Stainless Steel Housing	-Z
Stainless Steel Housing without SST gauges	-Z1
Stainless Steel Housing 10 bar supply.....	-ZK
Stainless Steel Housing 10 bar supply without SST gauges.....	-ZK1
Top Mounting version of SRD991 with built-in linear potentiometer	-W
LCD with Menu-Language in English / German / French.....	-V01
LCD with Menu-Language in English / German / Spanish.....	-V02
LCD with Menu-Language in English / German / Portuguese.....	-V03
LCD with Menu-Language in English / German / Polish	-V04
LCD with Menu-Language in English / German / Czech.....	-V05
LCD with Menu-Language in English / German / Italian	-V06
LCD with Menu-Language in English / German / Turkish	-V07
LCD with Menu-Language in English / German / Swedish	-V08
LCD with Menu-Language in English / German / Finnish	-V09
LCD with Menu-Language in English / German / Chinese.....	-V10
LCD with Menu-Language in English / German / Russian.....	-V11
LCD with Menu-Language in English / German / Hungarian	-V12
LCD with Menu-Language in English / German / Serbian.....	-V13
LCD with Menu-Language in English / German / Dutch.....	-V14
LCD with Menu-Language in English / German / Romanian.....	-V15
LCD with Menu-Language in English / German / Lithuanian	-V16
Tag No. Labeling	
Stamped With Weather Resistant Color.....	-G
Stainless Steel Label Fixed With Wire	-L

- (a) ONLY WITH (additional Inputs/Outputs E) AND (Optional Feature -B)
- (b) Not released
- (c) Only with Input/Communication D, H
- (d) Only with Input/Communication F, H, P and Q
- (e) NOT WITH (electrical certification ZZZ, EA4, EAA, GA4, GAA)
- (f) Available WITH (Version: C) AND (Built-in Limit Switch: S, D) AND (Electrical Classification: ZZZ, EA4, EAA, GA4, GAA, NFM, FAA) OR WITH (Version: B) AND (Built-in Limit Switch: S, D) AND (Electrical Classification: ZZZ, EA4, EAA, GA4, GAA, NFM, FAA)
- (g) Available ONLY WITH (Electrical Classification:FAA, NFM, CAA)
- (h) Available WITH (Version: B) OR WITH (Version: C) AND (Optional Features: S)
- (j) ONLY WITH (Built-in limit switch -S) AND (Electrical Classification EAx, NFM, FAA, GAx)
- (k) Only with ELECTRICAL CLASSIFICATION EA4, EAA or ZZZ
- (l) NOT WITH (optional feature -N OR Z OR Z1)
- (m) Available WITH (Version: C) AND (Built-in Limit Switch: S, D) AND (Electrical Classification: ZZZ, EA4, EAA, EDA, ED4, GA4, GAA, NFM, FAA) AND (Optional feature -S) NOT WITH (Optional feature -B)
- (n) Only with Version -C
- (s) Only available with Optional Feature LCD (-V01 to -Vxx) (u) Only with Electrical Classification: ZZZ
- (v) Only available for Input/Communication F, H, P and Q in connection with Electrical Classification ZZZ, FAA, NFM, EAA, CAA & GAA
- (w) Only available for Version single-acting -B in connection with Input/Communication -D and -H (x) Only in connection with Optional Features -B
- (y) Not with Optional Features -B
- (z) Not available with Electrical Classification FAA, NFM and CAA
- (1) On request

Accessories, for all basic devices

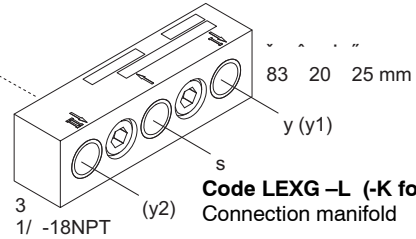
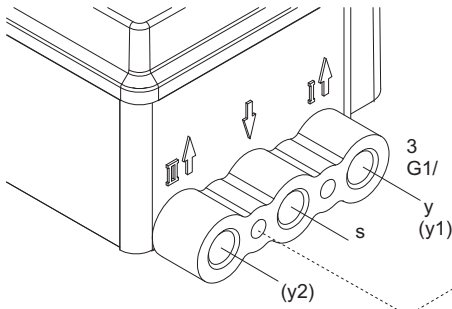

Code LEXG-L (-K for G1/4)
Connection manifold

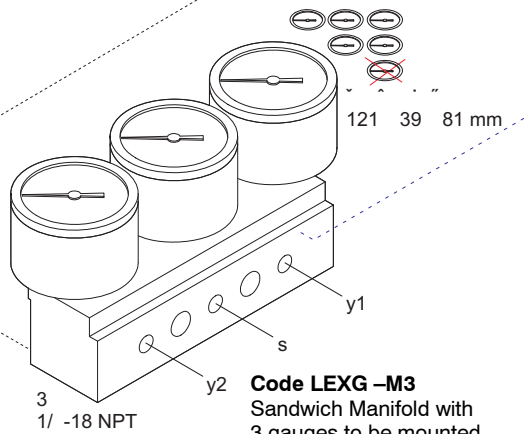

Code LEXG-M3
Sandwich Manifold with
3 gauges to be mounted
together with Volume booster
type LEXG-Gx

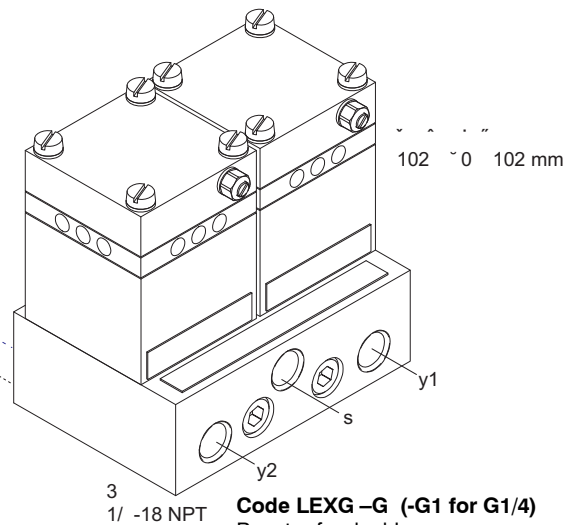

Code LEXG-G (-G1 for G1/4)
Booster for double
acting positioner

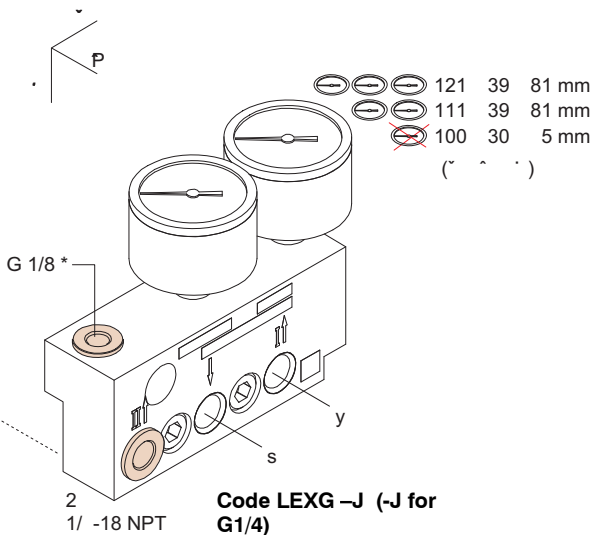

Code LEXG-J (-J for G1/4)
Connection manifold for
single acting positioner
with pressure gauges for
supply air s and output y

Code LEXG-M (-M for G1/4)
Connection manifold for
double acting positioner
with pressure gauges for
supply air s and output y1 and y2

Code LEXG-N (-N for G1/4)
as -M, M1, but without pressure gauges

* Unused threads for pressure are closed
by means of lock screw Part No. 425 024 013

MODEL CODES Accessories

010414

Accessories for intelligent Positioners**Filter Regulators**

Filter Regulator FRS923-2SK Filter Regulator for -40°C to 80°C.....	FRS01
Filter Regulator Filter Regulator for -20°C to 70°C.....	FRS02
Filter Regulator Stainless Steel (316) Filter Regulator	FRS03
Mounting Bracket for FRS02 or FRS03.....	EBZG-FR1
Orientable Mounting Bracket for FRS02 or FRS03	EBZG-FR2
Nipple for direct mounting Filter regulator 1/4 NPT both sides.....	VG-91

Communication / Modem / DTM

HART USB Modem (made by Ifak) with ATEX IS Certification	MOD900
DTM for SRD Serie for HART / FF / Profibus / FoxCom	VALCARE
ATEX IS Barrier Rail Mounted Module, 1 Channel, ATEX Ex ia IIC / FM Intrinsically Safe (TV228-SEGX) .	TV228

Booster Relay

Booster Cv 1 - Alu Housing - Remote mount (f).....	VBS100
Booster Cv 1 - SST Housing - Remote mount (g)	VBS110
Booster Cv 7 - Alu Housing - Remote mount (b)	VBS300
Booster Cv 7 - SST Housing - Remote mount (b)	VBS310
Booster Relay with connection 1/4-18 NPT.....	LEXG-G
Booster Relay with connection G 1/4	LEXG-G1

Surge / Lightning Protection

Surge/Lightning Protection for 4-20 mA with or without HART type TP48-N-NDI.....	BUSG-L1
Surge/Lightning Protection for FF/Profibus type TP32-N-NDI.....	BUSG-L4

Lock-in Relays

Lock-In Relay for lost of air supply for single acting / NAMUR Mounting	LEXG-VR1
Lock-In Relay (Fail Freeze) for lost of air supply and electric power for single and double acting / SRI990 direct mounting	LEXG-VR6
Lock-In Relay for lost of air supply for single and double acting / direct mounting.....	LEXG-VR8

wirelessHART module

WirelessHART Module Type Mactek BULLET for PST Monitoring (no Ex)	BUSG-WH1
WirelessHART Module Type Mactek BULLET for PST Monitoring (Intrinsically Safe ATEX+FM) ..	BUSG-WH2

Cable Gland

Cable Gland, M20x1.5 Plug-Connector For Fieldbus (ss/Threaded Connection 7/8 - UN).....	BUSG-F2
Cable Gland, M20x1.5 Plastics, Color Gray / Black	BUSG-K6
Cable Gland, M20x1.5 Plastics, Color Blue	BUSG-K7
Cable Gland, M20x1.5 Plastics, Color White	BUSG-K9
Cable Gland, M20x1.5 Plug-Connector For Fieldbus (ss/Threaded Connection M12)	BUSG-P3
Cable Gland, M20x1.5 HF For Fieldbus.....	BUSG-P4
Cable Gland, M20x1.5 Stainless Steel.....	BUSG-S6

Tube Fittings

Tube Fittings, G 1/4 A, 6x1mm , 1 pc.....	VG-01
Tube Fittings, G 1/4 A, 6x1mm, 2 pcs	VG-02
Tube Fittings, G 1/4 A, 6x1mm, 3 pcs	VG-03
Tube Fittings, 1/4 NPT, 6x1mm, 2 pcs	VG-52
Tube Fittings, 1/4 NPT, 6x1mm, 3 pcs	VG-53

Adapter

Adapter (Brass With Nickel Coating) M20 x 1.5 to 1/2 - 14 NPT (Internal Thread)	AD-A5
Adapter (ss) M20x1.5 to 1/2-14 NPT (Internal Thread)	AD-A6
Adapter (ss) M20x1.5 to G 1/2" (Internal Thread)	AD-A8
Adapter (Plastic) M20x1.5 to PG13.5 (Internal Thread)	AD-A9

MODEL CODES Attachment kits

012007

ACCESSORIES FOR POSITIONER (SRD991, SRI990, SRD960)

Attachment Kit	EBZG
For diaphragm actuators with casting yoke acc. NAMUR (incl. standard Couple lever).....	-H
For diaphragm actuators with pillar yoke acc. NAMUR (incl. standard Couple lever)	-K
For directly mounting (incl. standard Couple lever)	-D
For mounting to rotary actuators acc. VDI/VDE 3845 (without bracket)	-R
ForFoxTop/FoxPak	(g) -E
Brackets VDI/VDE 3845 (A = 130 mm / 5.12 in; B = 50 mm / 1.97 in).....	-C3
Brackets VDI/VDE 3845 (A = 80 mm / 3.15 in; B = 30 mm / 1.18 in).....	-C2
Brackets VDI/VDE 3845 (A = 80 mm / 3.15 in; B = 20 mm / 0.79 in).....	-C1
For Badger Meter - Research Control Series 754 and 755 Size 1/2 inch.....	-B1
For Fisher 657, 667 (linear) size 30 and 40	-F1
1051, 1052, 1061 size 40.....	-F2
657, 667 size 30 and 60.....	-F3
657, 667 size 70 and 100.....	-F4
1051, 1052, 1061 size 33.....	-F5
1051, 1052, 1061 size 60.....	-F6
For Foxboro P-Series / such as -H with installed height 80 mm (3.15 in).....	-H1
NAMUR-Attachment kit for centered mounting position on the casting yoke	-H2
For mounting on ADAR control valve.....	-H3
Micro flow control valve.....	(k) -H4
Such as -K with installed height 80 mm (3.15 in).....	-K1
For Kinetrol (Actuator Size 05).....	-K2
(Actuator Size 07).....	-K3
(Actuator Size 09).....	-K4
For Metso / Neles Rotary actuators Type AB6 and Type BJ & BC size 8 and 10, B1C11	-L1
Type BJ and BC size12 and 16, B1C17.....	-L2
For ARI-Armaturen - Direct Mounting to actuator type DR	-P1
For ARCA - Direct Mounting to actuator type BR 812	-P2
For Samson Type 3277 with 1/4 - 18 NPT.....	-S1
Type 3277 with G 1/4.....	-S2
Type 3277 with 1/4 - 18 NPT and gauges for supply and output pressure..... (g)	-S5
Type 3277 with G 1/4 and gauges for supply and output pressure..... (g)	-S6
Microflow Type 3277-5..... (k).....	-S8
Tuflin/XOMOX Type MX60	(h) -T1
Type MX200..... (h).....	-T2
Type MX450 / Type MX750 / Type MX1250	(h) -T3
Type MX3000..... (h).....	-T4
For Hagan actuators (left of pneumatic cylinder)	-X2
(right of pneumatic cylinder).....	-X1
For AMRI rotary actuator (requires minor modification of actuator. Please consult us before ordering!)	-X3
For Siemens actuators V-Series.....	-S3
For Sereg Maxflo, Revca, Reglob new type	-S4
Maxflo "old type"	-S7
CNX (Flowserve).....	-S9
For Masoneilan Type Camflex II.....	-M
47/48 (Sigma-F)	-M1
Type 37/38 size 15 and 18 (complete kit)	-M2
Type 87/88 all sizes	-M4
Varipac.....	-M5
37/38 size 9,11,13.....	-M6
/Severn Glocon Type Domotor size small..... (h).....	-M7
For Valtek Linear Actuator all Sizes - Stroke up to 4 inch / 102 mm.....	-V1
For VETEC Type R150.....	-V2

*) We recommend to contact our field service dept. before selection of these mounting kits.
Further Attachment kits on request.

MOUNTING TO LINEAR ACTUATORS

Attachment to stroke actuators acc. to IEC 534-6 (NAMUR), left hand

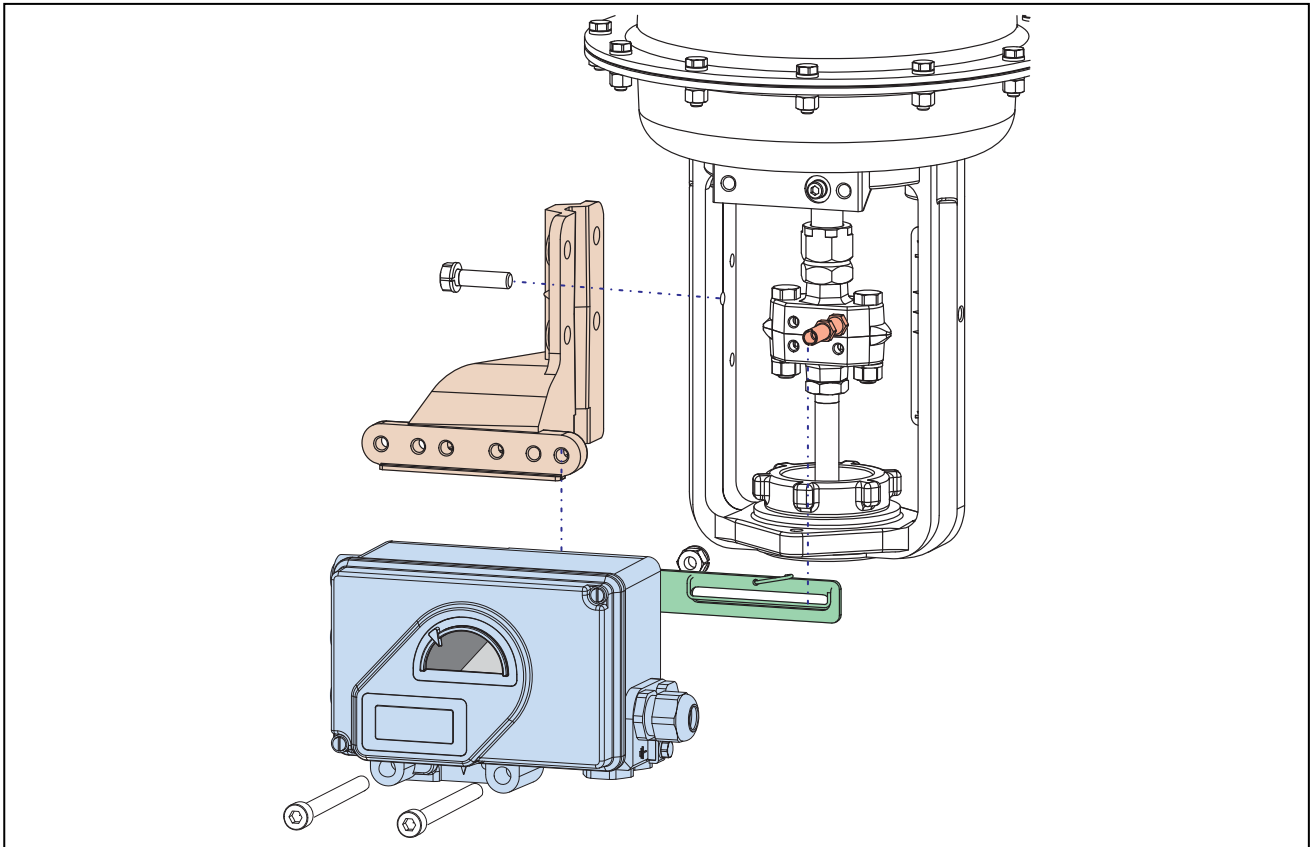

MOUNTING TO LINEAR ACTUATORS

Direct attachment to stroke actuators

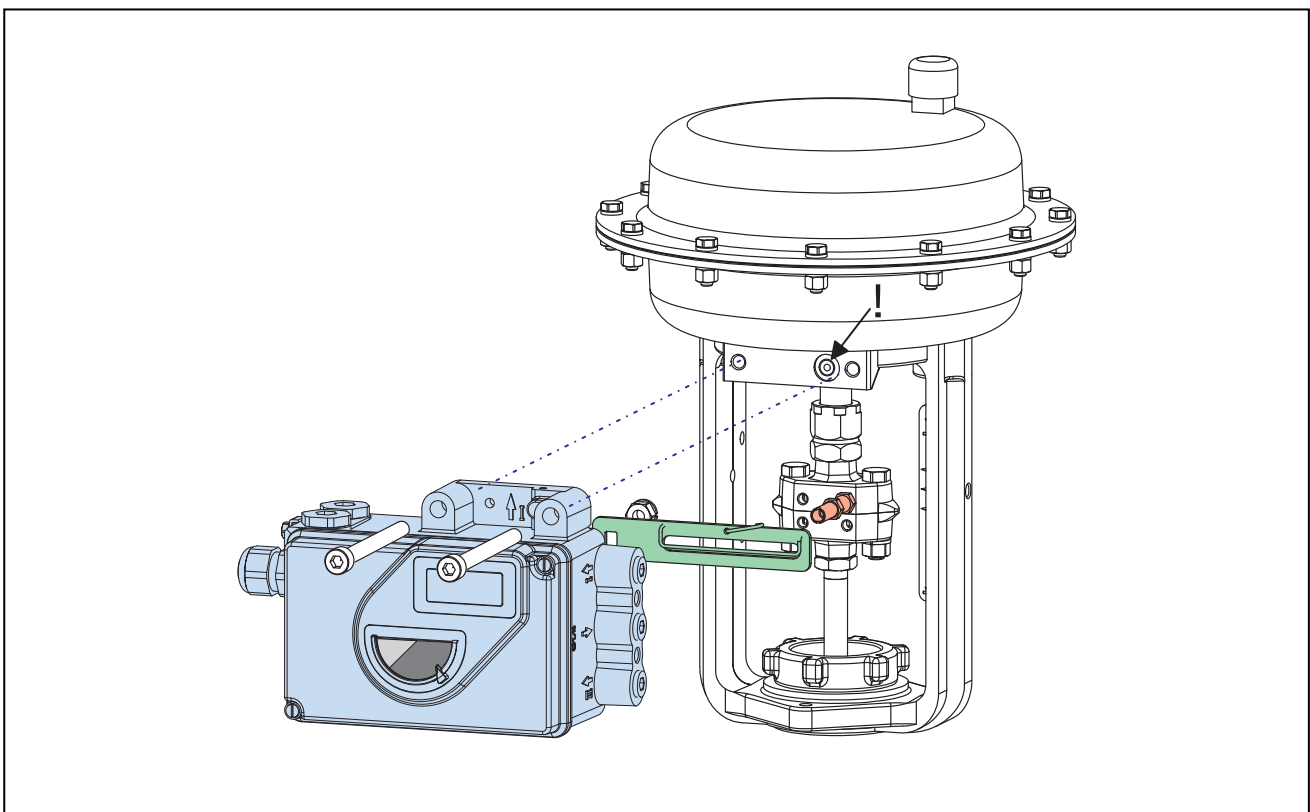

MOUNTING TO LINEAR ACTUATORS

Attachment to stroke actuators acc. to IEC 534-6 (NAMUR), right hand

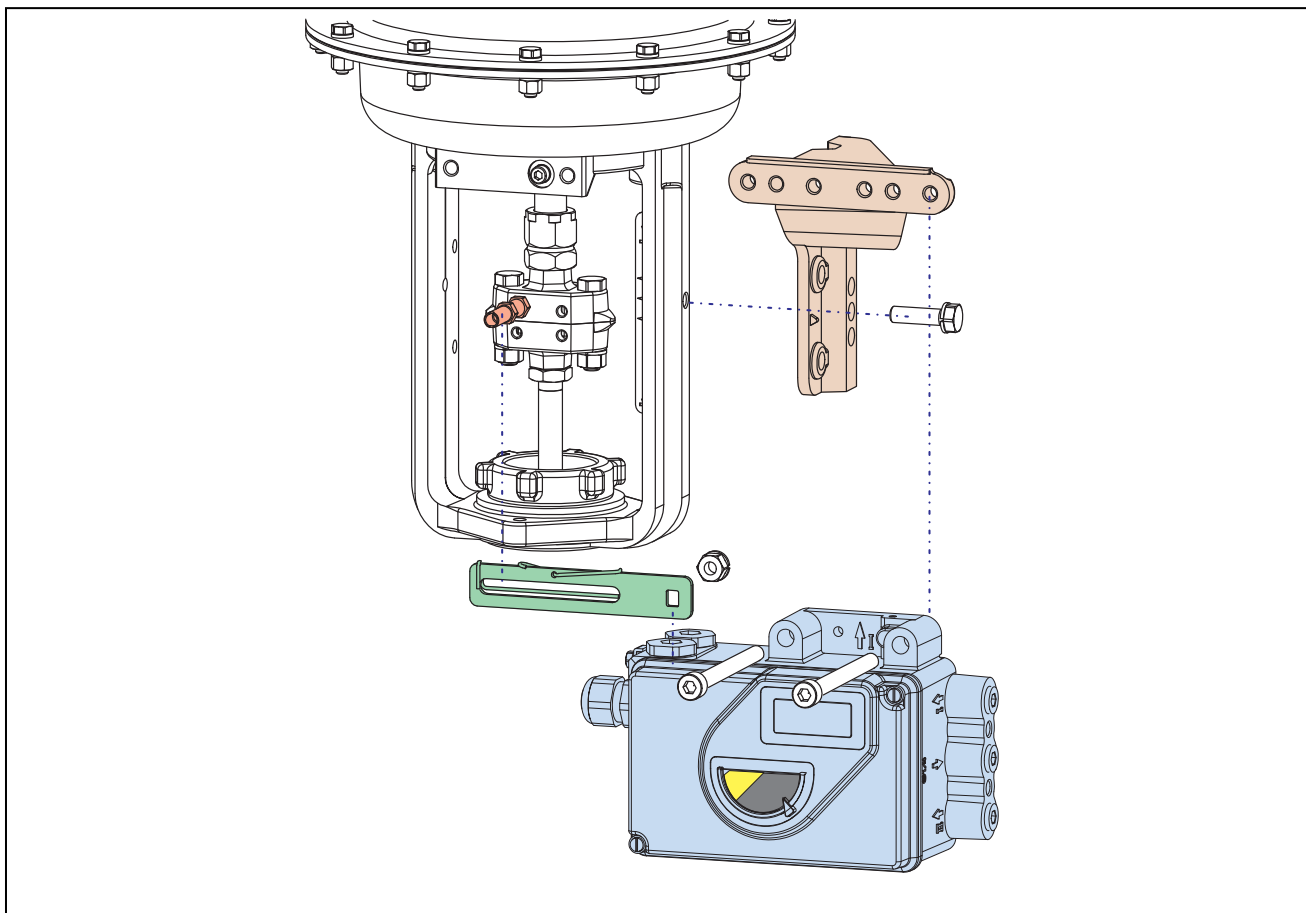

MOUNTING TO ROTARY ACTUATORS

Delivery of bracket by manufacturer of actuator

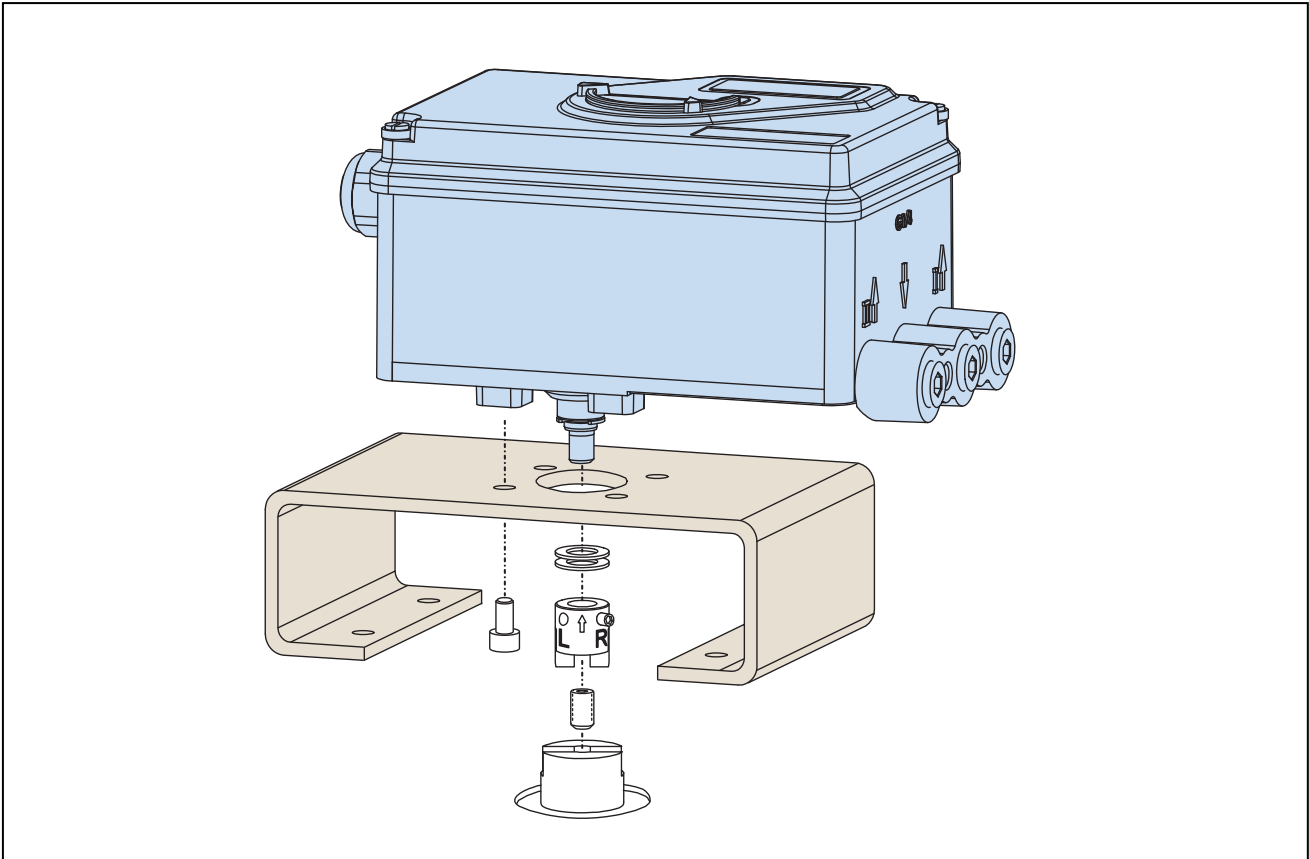

DIMENSIONS – Attachment to rotary actuators acc. to VDI/VDE 3845

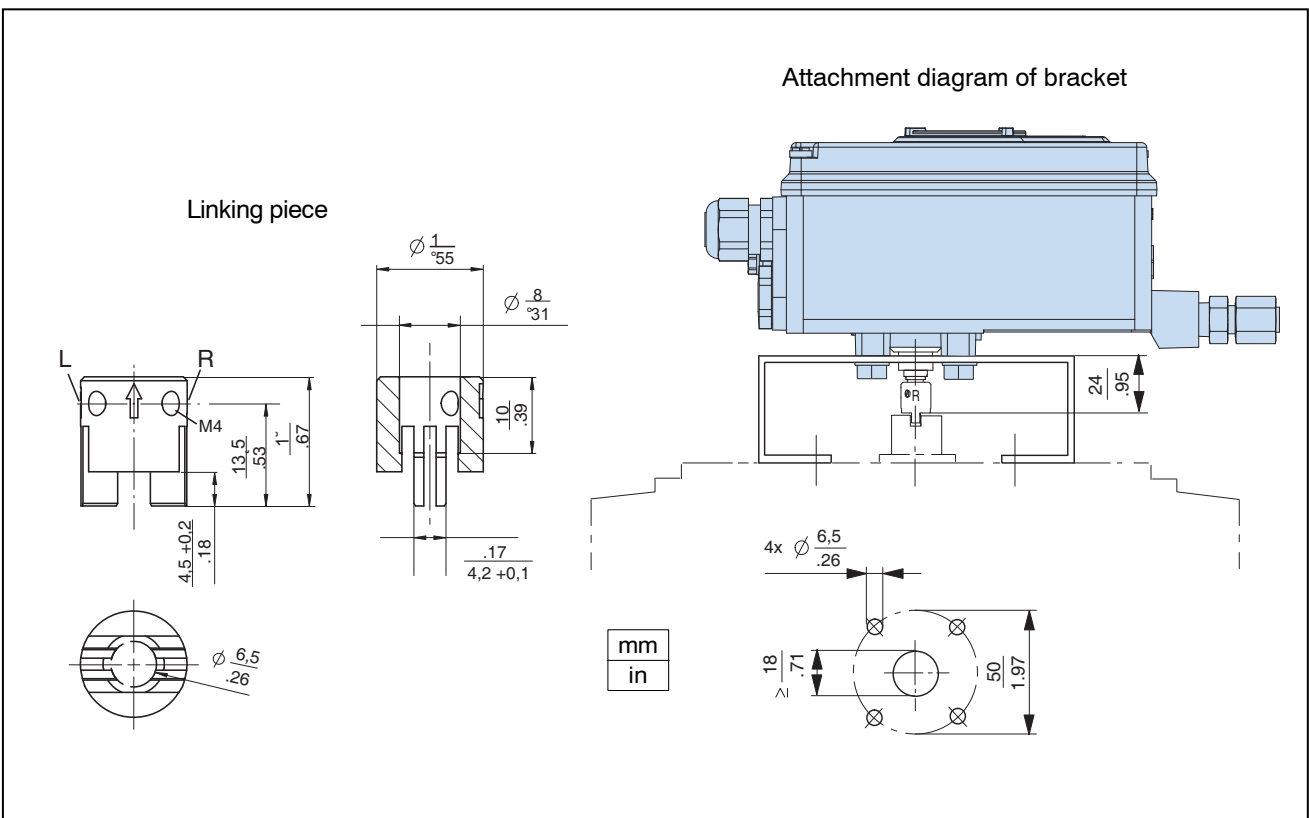

MOUNTING acc. to VDI/VDE 3847

Mounting to Linear actuators

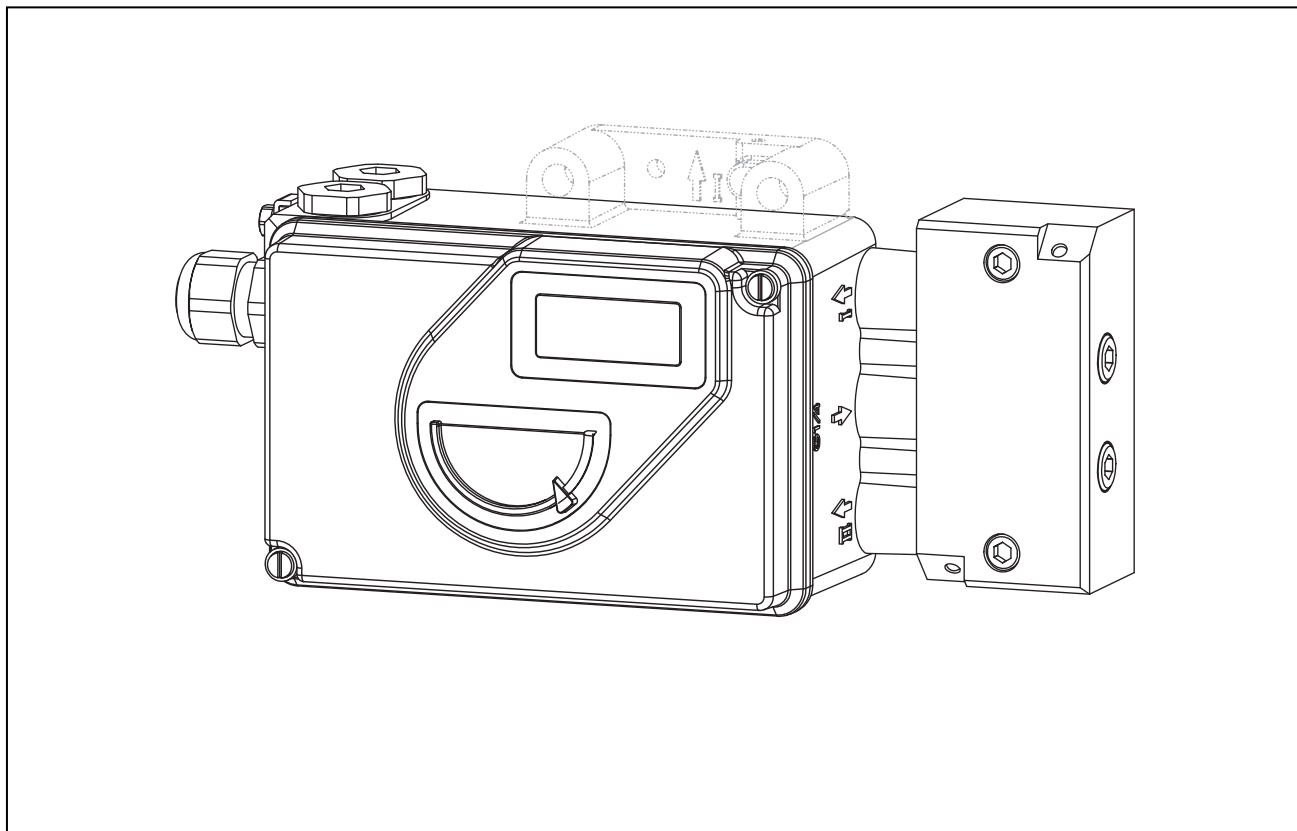

Mounting to Rotary actuators

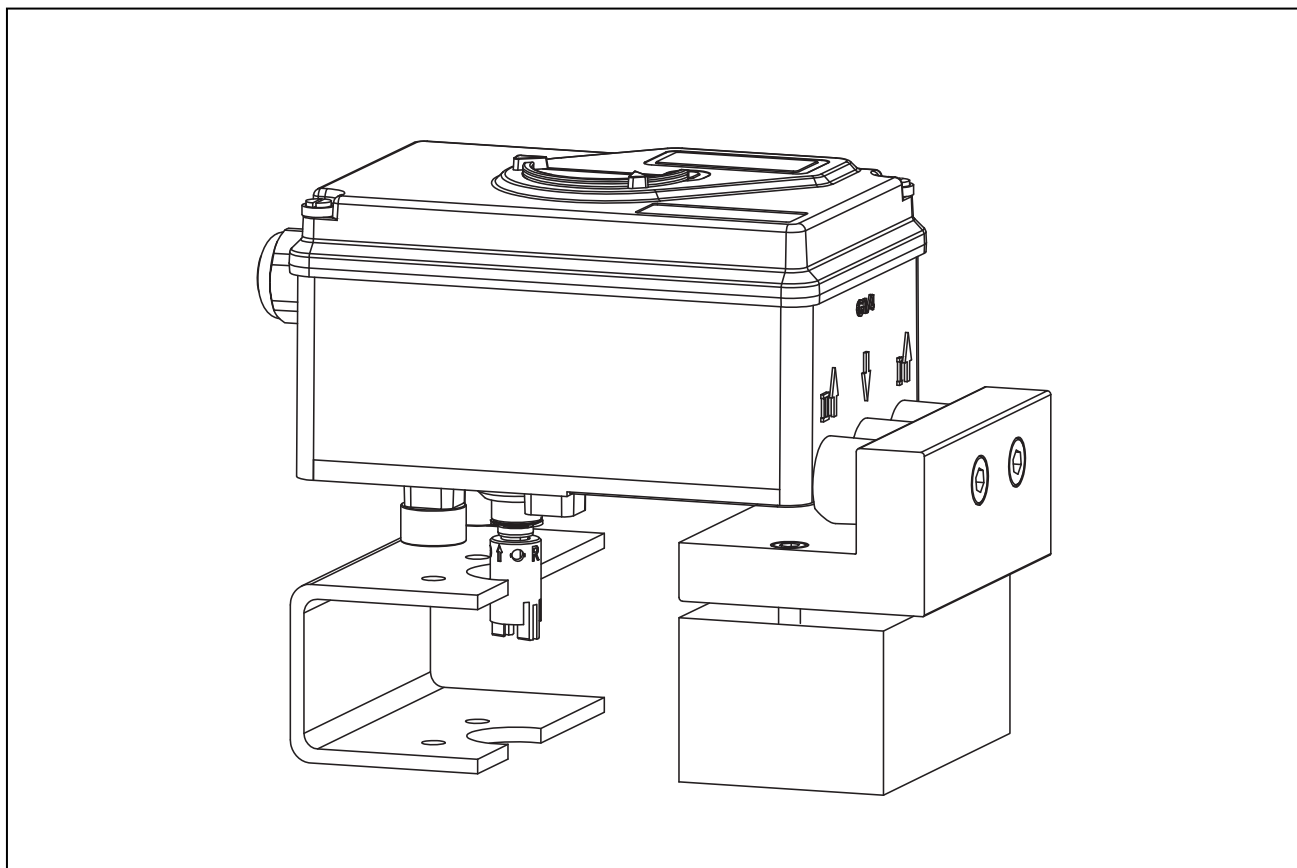

DIMENSIONS

Components of Attachment kits (samples)

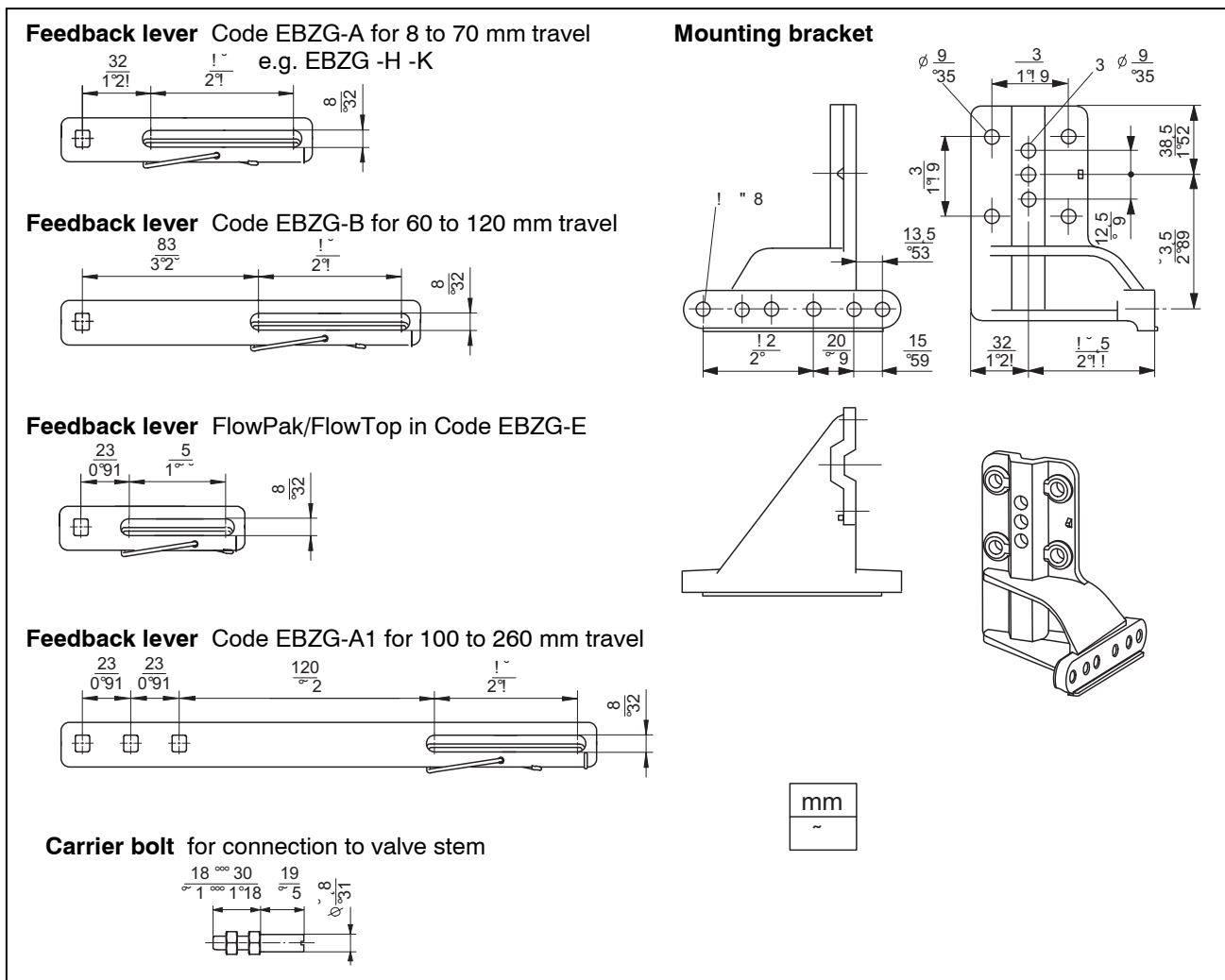

Weights of LEXG manifolds

- LEXG -F = 0.90 kg
- LEXG -F1 = 1.00 kg
- LEXG -G = 1.25 kg
- LEXG -G1 = 1.38 kg
- LEXG -H = 1.40 kg
- LEXG -H1 = 1.55 kg
- LEXG -J/-J1 = 0.40 kg
- LEXG -M/-M1 = 0.45 kg
- LEXG -N/-N1 = 0.28 kg
- LEXG -K = 0.12 kg

DIMENSIONS INOX SRD991 in stainless steel housing

