



ACVATIX™

## Modulating refrigerant valves with magnetic actuator, PS45

MVL661...-..

Hermetically sealed, for safety refrigerants

- One valve type for expansion, hot-gas and suction throttle applications
- Hermetically sealed towards outside
- Selectable standard interface DC 0/2...10 V or DC 0/4...20 mA
- High resolution and control accuracy
- Precise positioning control and position feedback signal
- Short positioning time (< 1 s)
- Closed when deenergized
- Robust and maintenance-free
- Six valve sizes with  $k_{vs}$  values from 0.25 to 12 m<sup>3</sup>/h

### Use

The MVL661...-.. refrigerant valve is designed for modulating control of refrigerant circuits including chillers and heat pumps. It can be used in expansion, hot-gas and suction throttle applications as well as with all commonly used refrigerants (R134a, R448A, R449A, R450A, R452A, R513A etc.) and R744 (CO<sub>2</sub>).

## Type summary

Type reference	DN	$k_{vs}$ [m <sup>3</sup> /h]	$k_{vs}$ reduced <sup>1)</sup> [m <sup>3</sup> /h]	$\Delta p_{max}$ [MPa]	$Q_0 E$ [kW]	$Q_0 H$ [kW]	$Q_0 D$ [kW]
MVL661.15-0.4	15	0.40		2.5	38	11	1.6
			0.25		24	6.9	1.0
MVL661.15-1.0	15	1.0			96	27	4.1
			0.63		61	17	2.6
MVL661.20-2.5	20	2.5			242	69	10
			1.6		155	44	6.6
MVL661.25-6.3	25	6.3			610	176	26
			4		387	111	16
MVL661.32-10	32	10		1.6	969	279	41
			6.3	610	176	26	
MVL661.32-12	32	12		0.2	2)	2)	49
			8	2)	2)	33	

<sup>1)</sup> 63% of  $k_{vs}$ , refer to " $k_{vs}$  reduction" on page 4

<sup>2)</sup> MVL661.32-12.0 is only approved for suction throttle applications

$k_{vs}$  Nominal flow rate of refrigerant through the fully open valve ( $H_{100}$ ) at a differential pressure of 100 kPa (1 bar) to VDI 2173

$Q_0 E$  Refrigeration capacity in expansion applications

$Q_0 H$  Refrigeration capacity in hot-gas compressor bypass applications  
Calculated base: Isentropic efficiency of 0.67

$Q_0 D$  Refrigeration capacity in suction throttle applications and  $\Delta p = 0.5$  bar

$Q_0$  With R448A at  $t_0 = -10^\circ\text{C}$  and  $t_c = 45^\circ\text{C}$

The pressure drop across evaporator and condenser is assumed to be 0.3 bar each, and 1.6 bar upstream of the evaporator (e.g. spider).

The capacities specified are based on superheating by 6 K and subcooling by 2 K.

The refrigeration capacity for various refrigerants and operating conditions can be calculated for the 3 types of application using the tables on page 15 .

For accurate valve sizing, we recommend the valve selection program "Refrigeration VASP".

### Accessories

PTC conductive heating element ASR70

ASR70 extends the application range of valves for refrigerant temperatures at the valve inlet below  $0^\circ\text{C}$ . Typical applications pump systems with  $\text{CO}_2$  refrigerant machines.

Direct mounting on refrigerant valve, no adjustments.



See data sheet A6V11858863.

The PTC conductive heating element is supplied complete with Mounting Instructions A6V11858868.

### Ordering

Valve body and magnetic actuator form one integral unit and cannot be separated.

Example:

Product number	Stock number	Designation
MVL661.15-0.4	MVL661.15-0.4	Refrigerant valve

### Spare parts

If the valve's electronics become faulty, the entire electronics housing must be replaced by spare part ASR61, supplied complete with mounting instructions (74 319 0270 0).

Rev. no.

See table on page 20.

**Features and benefits**

- 4 selectable standard signals for setpoint and measured value
- DIP switch to reduce the  $k_{vs}$  value to 63% of the nominal value
- Potentiometer for adjustment of minimum stroke for suction throttle applications
- Automatic stroke calibration
- Forced control input for “Valve closed” or “Valve fully open”
- LED for indicating the operating state

**Drive**

The MVL661... can be driven by Siemens or third-party controllers that deliver a DC 0/2...10 V or DC 0/4...20 mA output signal.  
 For optimum control performance, we recommend a 4-wire connection between controller and valve. When operating on DC voltage, a 4-wire connection is **mandatory!**  
 The valve stroke is proportional to the control signal.

**Spring return facility**

If the positioning signal is interrupted, or in the event of a power failure, the valve’s return spring will automatically close control path A → AB.

**Operator controls and indicators in the electronics housing**

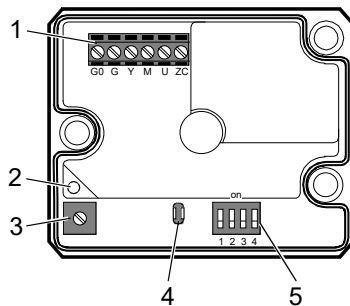

- 1 Connection terminals
- 2 LED for indication of operating state
- 3 Minimal stroke setting potentiometer Rv
- 4 Autocalibration
- 5 DIL switches for mode control

**Configuration of DIL switches**

Switch	Function	ON / OFF	Description
ON 4744Z02 1	Positioning signal Y	ON	Current [mA]
		OFF	<b>Voltage [V]</b> <sup>1)</sup>
ON 4744Z03 2	Positioning range Y and U	ON	DC 2...10 V, 4...20 mA
		OFF	<b>DC 0...10 V</b> , 0...20 mA <sup>1)</sup>
ON 4744Z04 3	Position feedback U	ON	Current [mA]
		OFF	<b>Voltage [V]</b> <sup>1)</sup>
ON 4744Z05 4	Nominal flow rate $k_{vs}$	ON	63%
		OFF	<b>100%</b> <sup>1)</sup>

<sup>1)</sup> **Factory setting**

**$k_{vs}$ -reduction**

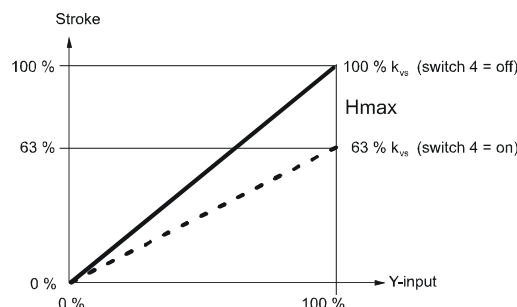

For  $k_{vs}$  reduction (DIL switch 4 in position ON), the stroke is limited to 63% mechanical stroke. 63% of full stroke then corresponds to an input/output signal of 10 V.  
 If, in addition, the stroke is limited to 80%, for example, the minimum stroke is  $0.63 \times 0.8 = 0.50$  of full stroke.

### Minimum stroke setting

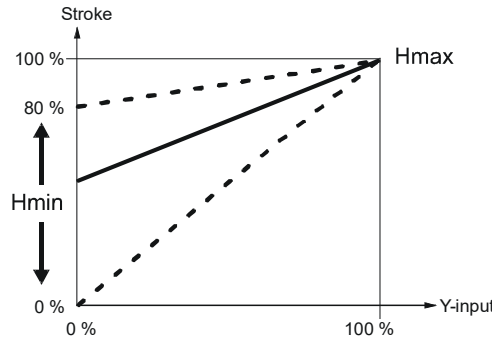

In the case of a suction throttle valve, it is essential that a minimum stroke limit be maintained to ensure compressor cooling and efficient oil return. This can be achieved with a reinjection valve, a bypass line across the valve, or a guaranteed minimum opening of the valve. The minimum stroke can be defined via the controller and control signal Y, or it can be set directly with potentiometer Rv.

The **factory setting** is zero (mechanical stop in counterclockwise direction, CCW). The minimum stroke can be set by turning the potentiometer clockwise (CW) to a maximum of 80%  $k_{vs}$ .

Caution

**Do not under any circumstances use potentiometer Rv to limit the stroke on expansion applications. It must be possible to close the valve fully.**

### Forced control input ZC

		ZC – Function		
		No function	Fully open	Closed
Connections				
function		<ul style="list-style-type: none"> <li>ZC not connected</li> <li>Valve will follow the Y-signal</li> <li>Minimum stroke setting with potentiometer Rv possible</li> </ul>	<ul style="list-style-type: none"> <li>ZC connected to G</li> <li>Valve will fully open control path A → AB</li> </ul>	<ul style="list-style-type: none"> <li>ZC connected to G0</li> <li>Valve will close control path A → AB</li> </ul>

### Signal priority

1. Forced control signal ZC
2. Signal input Y and/or minimum stroke setting with potentiometer Rv possible.

### Calibration

The printed circuit board of the MVL661... has a slot to facilitate calibration. To calibrate, insert a screwdriver in the slot so that the contacts inside are connected. As a result, the valve will first be fully closed and then fully opened.

Calibration matches the electronics to the valve mechanism.

During calibration, the green LED flashes for about 10 seconds; refer to "Indication of operating state" (page 5).



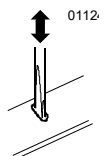

**MVL661... refrigerant valves are supplied fully calibrated.**



When is a calibration required?

Execute a calibration after replacing the electronics, when the red LED is lit or flashing or when the valve is leaking (at seat).

## Indication of operating state

LED	Indication	Function	Remarks, troubleshooting
Green	Lit 	Control mode	Automatic operation; everything o.k.
	Flashing 	Calibration in progress	Wait until calibration is finished (green or red LED will be lit)
Red	Lit 	Calibration error Internal error	Recalibrate (operate button in opening 1x) Replace electronics module
	Flashing 	Mains fault	Check mains network (outside the frequency or voltage range)
Both	Dark 	No power supply Electronics faulty	Check mains network, check wiring Replace electronics module

## Connection type <sup>1)</sup>

Always give preference to a 4-wire connection!

4-wire connection  
3-wire connection

Product number	S <sub>NA</sub> [VA]	P <sub>MED</sub> [W]	S <sub>TR</sub> [VA]	P <sub>TR</sub> [W]	I <sub>F</sub> [A]	Wire cross-section [mm <sup>2</sup> ]		
						1.5	2.5	4.0 <sup>2)</sup>
						max. cable length L [m]		
MVL661..-..	32	12	≥50	≥40	1.6...4 A	65	110	160
MVL661..-..	32	12	≥50	≥40	1.6...4 A	20	35	50

S<sub>NA</sub> = Nominal apparent power

P<sub>med</sub> = Typical power consumption in the application

S<sub>TR</sub> = Minimum apparent transformer power

P<sub>TR</sub> = Minimum DC supply power

I<sub>F</sub> = Minimal Required slow fuse

L = Max. cable length; with 4-wire connections, the max. permissible length of the separate 1.5 mm<sup>2</sup> copper positioning signal wire is 200 m

<sup>1)</sup> All information at AC 24 V or DC 24V

<sup>2)</sup> With 4 mm<sup>2</sup> electrical wiring reduce wiring cross-section for connection inside valve to 2.5 mm<sup>2</sup>.

## Sizing

For straightforward valve sizing, refer to the tables for the relevant application (from page 12).

For accurate valve sizing, we recommend to make use of the valve sizing software "Refrigeration Valve Selection Program RVASP", available from your local Siemens office.

### Notes

The refrigeration capacity Q<sub>0</sub> is calculated by multiplying the mass flow by the specific enthalpy differential found in the h, log p-chart for the relevant refrigerant. To help determine the refrigeration capacity more easily, a selection chart is provided for each application (page 12 and following). With direct or indirect hot-gas bypass applications, the enthalpy differential of Q<sub>c</sub> (the condenser capacity) must also be taken into account when calculating the refrigeration capacity.

If the evaporating and / or condensing temperatures are between the values shown in the tables, the refrigeration capacity can be determined with reasonable accuracy by linear interpolation (refer to the application examples on page 12 and following).

At the operating conditions given in the tables, the permissible differential pressure Δp<sub>max</sub> across the valve is not considered.

If the evaporating temperature is raised by 1 K, the refrigeration capacity increases by about 3%. If, by contrast, subcooling is increased by 1 K, the refrigeration capacity increases by about 1 to 2% (this applies only to subcooling down to approximately 8 K).

Depending on the application, additional installation instructions may need to be observed and appropriate safety devices (e.g. pressostats, full motor protection, etc.) fitted.

**Warning** 

To prevent damage to the seal inside the valve insert, the plant must be vented on the low-pressure side following a pressure test (valve port AB), or the valve must be fully open during the pressure test and during venting (power supply connected and positioning signal at maximum or forced opening by G → ZC).

**Expansion application**

To prevent formation of flash gas on expansion applications, the velocity of the refrigerant in the fluid pipe may not exceed 1 m/s. To assure this, the diameter of the fluid pipe must be greater than the nominal size of the valve, using reducing pieces for making the connections to the valve.

Engineering notes

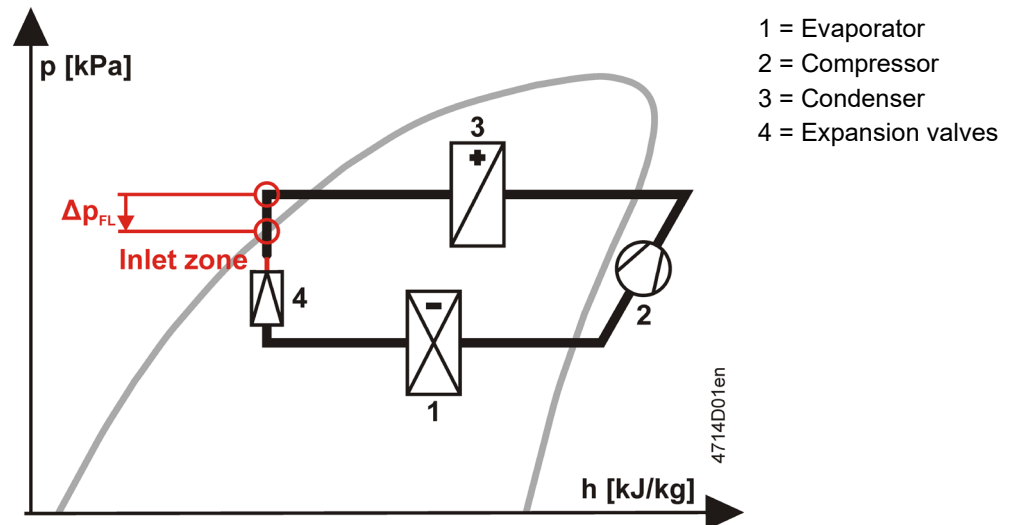

- a) The differential pressure over reduction must be less than half the differential pressure  $\Delta p_{FL}$ .
- b) The inlet path between diameter reduction and expansion valve inlet
  - Must be straight for at least 600 mm
  - May not contain any valves

**A filter / dryer must be mounted upstream of the expansion valve.  
The valve is not explosion-proof.  
It is not approved for use with ammonia (NH<sub>3</sub>, R717).**

## Mounting notes

The valve should be mounted and commissioned by qualified staff. The same applies to the replacement electronics and the configuration of the controller (e.g. SAPHIR or PolyCool).

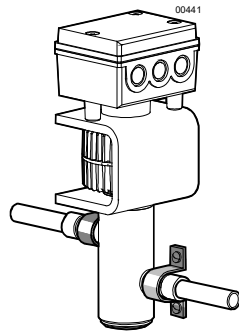
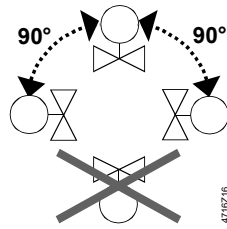

- The refrigerant valves can be mounted in any orientation, but upright mounting is preferable.
- Arrange the pipework in such a way that the valve is not located at a low point in the plant where oil can collect.
- The pipes should be fitted in such a way that the alignment does not distort the valve connections. Fix the valve body so that that it cannot vibrate. Vibration can lead to burst connection pipes.
- Before soldering the pipes, ensure that the direction of flow through the valve is correct.
- The pipes must be soldered with care. To avoid dirt and the formation of scale (oxide), inert gas is recommended for soldering.
- The flame should be large enough to ensure that the junction heats up quickly and the valve does not get too hot.
- The flame should be directed away from the valve.
- During soldering, cool the valve with a wet cloth, for example, to ensure that it does not become too hot.
- The valve body and the connected pipework should be lagged.
- The actuator must not be lagged.

The valve is supplied complete with mounting instructions 74 319 0232 0.

## Maintenance

The refrigerant valve is maintenance-free.

## Repair

The valve cannot be repaired. It has to be replaced as a complete unit.

## Disposal



The valve is considered electrical and electronic equipment for disposal in terms of the applicable European Directive and may not be disposed of as domestic garbage.

- Dispose of the valve through channels provided for this purpose.
- Comply with all local and currently applicable laws and regulations.

## Warranty

Observe all application-specific technical data.

**If you ignore specified limits, Siemens will not assume any responsibility.**

## Technical data

### Functional actuator data

Power supply	Extra low-voltage only (SELV, PELV)		
• AC 24 V	Operating voltage	AC 24 V $\pm$ 20% (SELV) or AC 24 V class 2 (US)	
	Frequency	45...65 Hz	
	Typical power consumption $P_{med}$	12 W	
	Standby	< 1 W (valve closed)	
	Rated apparent power $S_{NA}$	32 VA (for selecting the transformer)	
	Required fuse	1.6...4 A (slow)	
	External supply line protection	Fuse slow max. 10 A or Circuit breaker max. 13 A Characteristic B, C, D according to EN 60898 or Power source with current limitation of max. 10 A	
• DC 24 V	Operating voltage	DC 20...30 V	
	Current draw	0.5 A / 2 A (max.)	
Signal inputs	Control signal Y	DC 0/2...10 V or DC 0/4...20 mA	
	Impedance DC 0/2...10 V	100 k $\Omega$ / 5nF	
	Impedance DC 0 / 4...20 mA	240 $\Omega$ / 5nF	
	Forced control ZC		
	Input impedance	22 k $\Omega$	
	Close valve (ZC connected to G0)	< AC 1 V; < DC 0.8 V	
	Open valve (ZC connected to G)	> AC 6 V; > DC 5 V	
	No function (ZC not wired)	Positioning signal Y active	
Signal outputs	Position feedback signal U	Voltage	DC 0/2...10 V; load resistance $\geq$ 500 $\Omega$
		Current	DC 0/4...20 mA; load resistance $\leq$ 500 $\Omega$
	Stroke detection	Inductive	
	Nonlinearity	Accuracy $\pm$ 3 % full scale	
Positioning time	Positioning time	< 1 s	
Electrical connections	Cable entry glands	3 x $\varnothing$ 17 mm (for M16)	
	Min. wire cross-section	0.75 mm <sup>2</sup>	
	Max. cable length	See «Connection type», page 5	
	Max. differential pressure $\square p_{max}$	max. 4.5 MPa (45 bar) <sup>1)</sup>	
Product data valve	Max. differential pressure $\square p_{max}$	2.5 MPa (25 bar) MVL661.32-10: 1.6 MPa (16 bar) MVL661.32-12: 200 kPa (2 bar)	
	Valve characteristic (stroke, $k_v$ )	Linear (to VDI / VDE 2173)	
	Leakage rate (internally across seat)	Max. 0.002% $k_{vs}$ or Max. 1 NI/h gas at $\square p = 4$ bar Shut/off function, like solenoid normally closed (NC) function	
	External seal	Hermetically sealed (fully welded, no static or dynamic seals)	
	Permissible media	Commonly used refrigerants (R134a, R448A, R449A, R450A, R452A, R513A etc. such as R744 (CO <sub>2</sub> )). Not suitable for ammonia (R717).	
	Medium temperature		
		Refrigerant outlet (AB)	-40...120 °C; max. 140 °C for 10 min; without ASR70
		Refrigerant inlet (A)	1...120°C; max. 140°C für 10min; without ASR70
		Refrigerant inlet (A)	-40...0°C with ASR70 <sup>6)</sup>



	Stroke resolution $\square^H/H_{100}$	1 : 1000 (H = stroke)
	Hysteresis	Typically 3 %
	Mode of operation	Modulating
	Position when deenergized	Control path A → AB closed
	Orientation	Upright to horizontal <sup>2)</sup>
Materials	Valve body and parts	Steel / CrNi steel
	Seat / piston	CrNi steel / brass
	Sealing disk	PTFE
Pipe connections	Sleeves	Internally soldered, CrNi steel
Dimensions and weight	Dimensions	See "Dimensions" page 11
	Weight	See "Dimensions" page 11
Norms and directives	Electromagnetic compatibility (Application)	For residential, commercial and light-industrial environments
	Product standard	EN60730-x
	EU Conformity (CE)	CA2T4714xx <sup>3)</sup>
	RCM Conformity	A5W00004451 <sup>3)</sup>
	EAC Conformity	Eurasia Conformity for all MVL..
	Electrical safety	EN 60730-1
	Protection class	Class III as per EN 60730
	Degree of pollution	Degree 2 as per EN 60730
	Housing protection	
	Upright to horizontal	IP65 as per EN 60529 <sup>2)</sup>
	Vibration <sup>4)</sup>	EN 60068-2-6 5 g acceleration, 10...150 Hz, 2.5 h (5 g horizontal, max. 2 g upright)
	UL certification (US)	UL 873, <a href="http://ul.com/database">http://ul.com/database</a>
	CSA certification	C22.2 No. 24, <a href="http://csagroup.org">http://csagroup.org</a>
	Environmental compatibility	The product environmental declarations CA2E4714.1en <sup>3)</sup> , CA2E4714.2en <sup>3)</sup> and CA2E4714.3en <sup>3)</sup> contains data on environmentally compatible product design and assessments (RoHS compliance, materials composition, packaging, environmental benefit, disposal).
	Permissible operating pressure	PED 2014/68/EU
Pressure accessories	Scope: Article 1, section 1 Definitions: Article 2, section 5	
Fluid group 2:	DN 15...32	Without CE-marking as per article 4,
Fluid group 1 <sup>5)</sup> :	DN 15...25	section 3 (sound engineering practice)

<sup>1)</sup> To EN 12284 tested with 1,43 x operating pressure at 65 bar

<sup>2)</sup> At 45 °C < T<sub>amb</sub> < 55 °C and 80 °C < T<sub>med</sub> < 120 °C the valve must be installed on its side to avoid shortening the service life of the valve electronics

<sup>3)</sup> The documents can be downloaded from <http://siemens.com/bt/download>.

<sup>4)</sup> In case of strong vibrations, use high-flex stranded wires for safety reasons.

<sup>5)</sup> The manufacturer as well as the operator is obliged to comply with all legal requirements while handling with media belonging to fluid group 1.

<sup>6)</sup> See ASR70, data sheet A6V11858863

## General environmental conditions

	Operation EN 60721-3-3	Transport EN 60721-3-2	Storage EN 60721-3-1
Climatic conditions	Class 3K6	Class 2K3	Class 1K3
Temperature	-25...55 °C	-25...70 °C	-5...45 °C
Humidity	10...100% r. h.	< 95% r. h.	5...95% r. h.

**Connection terminals**

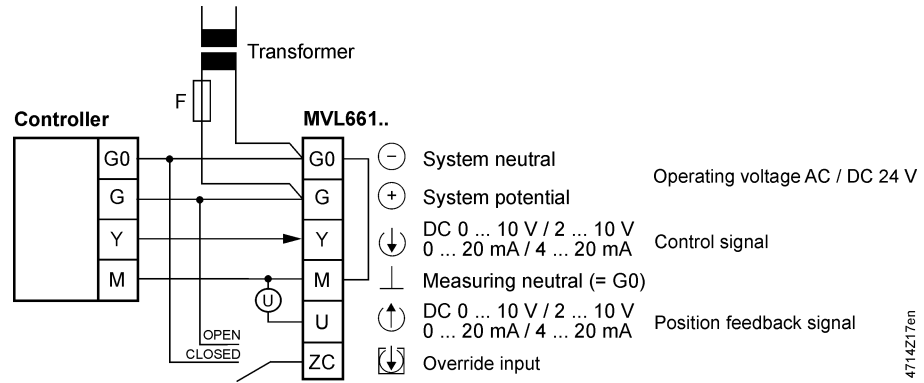

**Connection diagrams**

**Terminal assignment for controller with 4-wire connection (to be preferred!)**

**Common transformer**

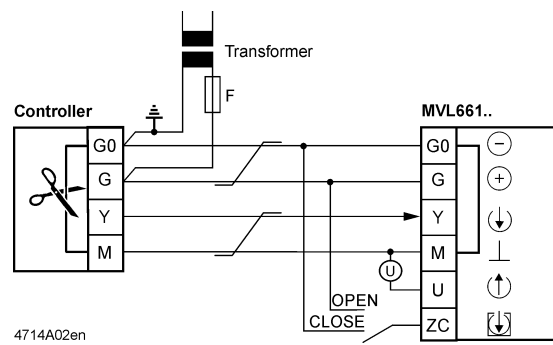

**Separate transformer**

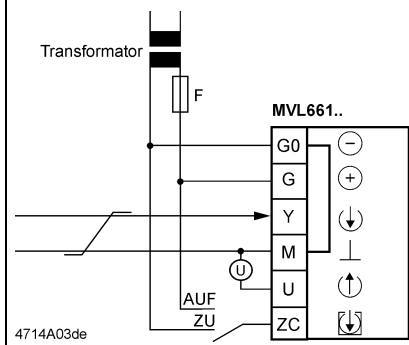

**Terminal assignment for controller with 3-wire connection**

**Common transformer**

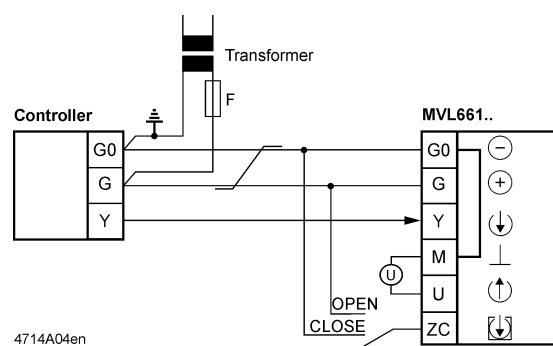

**Separate transformer**

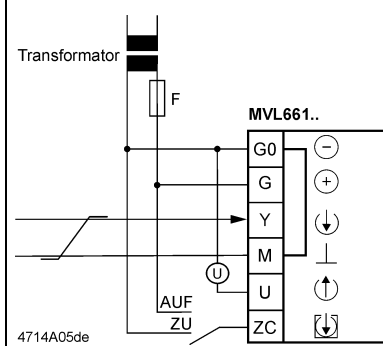

Indication of valve position (only if required). DC 0...10 V → 0...100% volumetric flow V100

Twisted pairs. If the lines for AC 24 V power supply and the DC 0...10 V (DC 2...10 V, DC 0...20 mA, DC 4...20 mA) positioning signal are routed separately, the AC 24 V line need not be twisted.

- Warning** **Piping must be connected to potential earth!**
- Ground only one transformer on the secondary side if the controller and valve are powered separately.**
- Caution** **In case of DC power supply, a 4-wire connection is mandatory!**

**DIL switch** Factory setting: Valve characteristics linear, positioning signal DC 0...10 V. Details see "Configuration DIL switches", page 3.

**Calibration** See "Calibration", page 4.

## Dimensions

Dimensions in mm

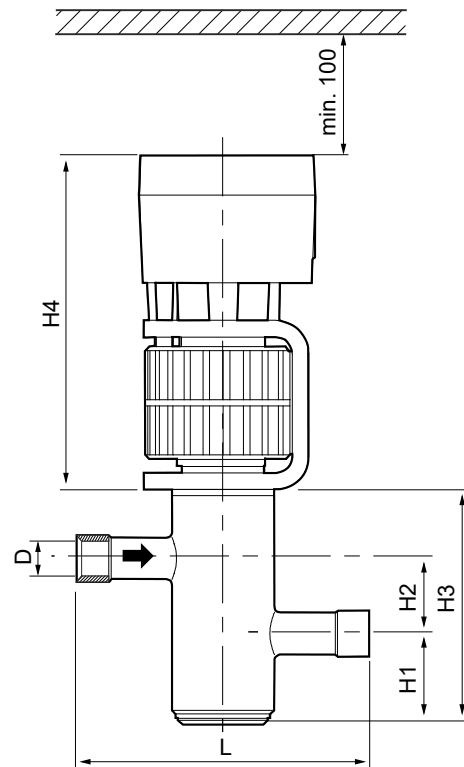

Type reference	DN	D [inch]	D [mm]	L [mm]	H1 [mm]	H2 [mm]	H3 [mm]	H4 [mm]	T [mm]	M [kg]
<b>MVL661.15-0.4</b>	15	5/8"	16	140	44	36	113	160	103	4.4
<b>MVL661.15-1.0</b>	15	5/8"	16	140	44	36	113	160	103	4.4
<b>MVL661.20-2.5</b>	20	7/8"	22	150	41	41	119	160	103	4.5
<b>MVL661.25-6.3</b>	25	1 1/8"	28	160	40	47	126	160	103	4.6
<b>MVL661.32-10</b>	32	1 3/8"	35	190	43	54	142	160	103	6.1
<b>MVL661.32-12</b>	32	1 3/8"	35	190	43	54	142	160	103	6.1

DN Nominal size

D Nominal diameter [inch] and [mm] of copper pipe congenial to the connecting branch

T Depth

M Weight including packaging [kg]

## Valve sizing with correction factor

The applications and tables on the following pages are designed for help with selecting the valves. To select the correct valve, the following data is required:

- **Application**
  - Expansion (starting on page 12)
  - Hot-gas (starting on page 16)
  - Suction throttle (starting on page 18)
- **Refrigerant type**
- **Evaporating temperature  $t_0$  [°C]**
- **Condensing temperature  $t_c$  [°C]**
- **Refrigeration capacity  $Q_0$  [kW]**

To calculate the nominal capacity, use the following formula:

- $k_{vs} [\text{m}^3/\text{h}] = Q_0 [\text{kW}] / K_{...} * K_{...}$ 
  - \*  $K_{...}$  for expansion = **KE**
  - for hot-gas = **KH**
  - for suction throttle = **KS**
- The theoretical kv value for the nominal refrigeration capacity of the plant should not be less than 40% of the kvs value of the selected valve.
- For accurate valve sizing, we recommend the valve selection program "Refrigeration Valve Selection Program RVASP".

The application examples on the following pages deal with the principles only. They do not include installation-specific details such as safety elements, refrigerant collectors, etc.

## Use of the MVL661... as an expansion valve

Note

Observe engineering notes page 6

- Typical control range 20...100%.
- Increased capacity through better use of the evaporator.
- The use of two or more compressors or compressor stages significantly increases efficiency with low loads.
- Especially suitable for fluctuating condensing and evaporating pressures.

### Capacity optimization

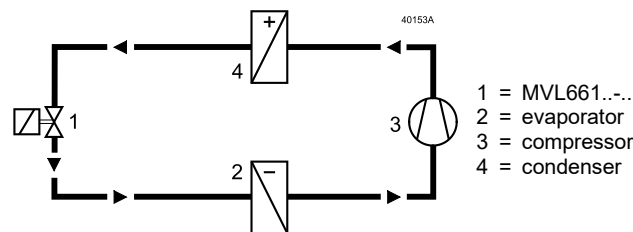

Electronic superheat control is achieved by using additional control equipment (e.g. PolyCool).

### Application example

Refrigerant R513A;  $Q_0 = 120 \text{ kW}$ ;  $t_0 = +5^\circ\text{C}$ ;  $t_c = +45^\circ\text{C}$

The correct  $k_{vs}$  value for the MVL661... valve needs to be determined.

The important section of table KE for R513A (see page 15) is the area around the working point. The correction factor KE relevant to the working point should be determined by linear interpolation from the four guide values.

Note on interpolation

In practice, the KE, KH or KS value can be estimated because the theoretical  $k_{vs}$ -value ascertained will be rounded off by up to 30% to one of the ten available  $k_{vs}$ -values, allowing you to proceed directly at Step 4.

- Step 1: For  $t_c = 45$ , calculate the value for  $t_0 = 0$  between values 40 and 60 in the table; result: **63.75**
- Step 2: For  $t_c = 45$ , calculate the value for  $t_0 = 10$  between values 40 and 60 in the table; result: **67**
- Step 3: For  $t_0 = 5$ , calculate the value for  $t_c = 45$  between correction factors 63.75 and 67; calculated in steps 1 and 2; result: **65.375**
- Step 4: Calculate the theoretical  $k_{vs}$  value; result: **1.84 m<sup>3</sup>/h**
- Step 5: Select the valve; the valve closest to the theoretical  $k_{vs}$  value is the **MVL661.20-2.5**
- Step 6: Check that the theoretical  $k_{vs}$  value is not less than 40 % of the nominal  $k_{vs}$  value

KE-R407C	$t_0 = -10\text{ °C}$	$t_0 = 0\text{ °C}$
$t_c = 40\text{ °C}$	<b>64</b>	<b>67</b>
$t_c = 45\text{ °C}$	-	-
$t_c = 60\text{ °C}$	<b>63</b>	<b>67</b>

Interpolation at $t_c = 45\text{ °C}$	
$64 - [(64-63) \times (45 - 40) / (60 - 40)]$	63.75
$67 - [(67 - 67) \times (45 - 40) / (60 - 40)]$	67

Interpolation at $t_0 = 5\text{ °C}$	
$63.75 + [(67 - 63.75) \times (5 - 0) / ((10 - 0))]$	65.375

$k_v$  theoretical =  $120\text{ kW} / 65.375\text{ kW}/(\text{m}^3/\text{h}) = 1.84\text{ m}^3/\text{h}$

Valve MVL661.20-2.5 is suitable, since:  $1.84\text{ m}^3/\text{h} / 2.5\text{ m}^3/\text{h} \times 100\% = 74\% (>40\%)$

## Capacity control

- a) Refrigerant valve MVL661... for capacity control of a dry expansion evaporator. Suction pressure and temperature are monitored with a mechanical capacity controller and reinjection valve.
- Typical control range 0...100%
  - Energy-efficient operation with low loads
    - Ideal control of temperature and dehumidification

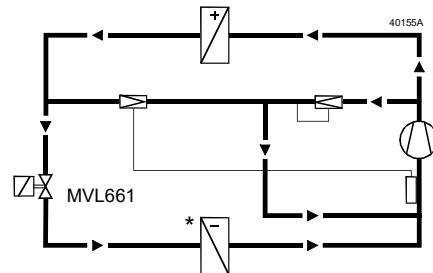

- b) Refrigerant valve MVL661... for capacity control of a chiller.
- Typical control range 10...100%
  - Energy-efficient operation with low loads
    - Allows wide adjustment of condensing and evaporating temperatures
    - Ideal for use with plate heat exchangers
    - Very high degree of frost protection

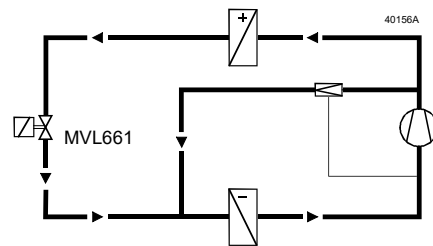

**Note** A larger valve may be required for low load operation than is needed for full load conditions. To ensure that the selected valve will not be too small for low loads, sizing should take account of both possibilities.

**Correction table KE**  
Expansion valve

$t_c \setminus t_o$	R32 <sup>1)</sup>					
°C	-30	-20	-10	0	10	20
0	125	126	30	-	-	-
20	154	156	158	159	98	-
40	175	178	180	182	184	184
60	-	-	-	-	-	190

$t_c \setminus t_o$	R134a					
°C	-30	-20	-10	0	10	20
20	57	59	62	43	-	-
40	64	68	71	74	77	73
60	65	69	73	77	81	85
80	54	59	64	69	74	78

$t_c \setminus t_o$	R290 <sup>1)</sup>					
°C	-40	-30	-20	-10	0	10
0	71	67	23	-	-	-
20	83	86	90	93	80	-
40	88	93	97	102	106	110
60	83	89	94	100	106	111

$t_c \setminus t_o$	R448A					
°C	-40	-30	-20	-10	0	10
20	64	66	45	-	-	-
40	77	80	83	86	86	33
60	84	88	92	95	99	102
80	80	84	89	94	98	102

$t_c \setminus t_o$	R449A					
°C	-40	-30	-20	-10	0	10
0	63	65	44	-	-	-
20	76	79	82	84	84	32
40	83	87	90	94	97	100
60	78	82	87	92	96	100

$t_c \setminus t_o$	R450A					
°C	-30	-20	-10	0	10	20
20	49	51	51	25	-	-
40	52	58	61	64	67	60
60	54	58	62	66	70	74
80	44	49	54	59	64	69

$t_c \setminus t_o$	R452A					
°C	-40	-30	-20	-10	0	10
0	54	56	42			
20	62	65	68	71	70	30
40	63	67	71	75	78	82
60	50	55	60	65	70	74

$t_c \setminus t_o$	R452B <sup>1)</sup>					
°C	-30	-20	-10	0	10	20
0	98	93	-	-	-	-
20	119	121	124	126	72	-
40	132	135	138	141	143	145
60	-	-	-	-	143	145

$t_c \setminus t_o$	R454B <sup>1)</sup>					
°C	-30	-20	-10	0	10	20
0	99	93	-	-	-	-
20	119	122	124	126	71	-
40	133	136	139	142	144	146
60	-	-	-	-	145	147

$t_c \setminus t_o$	R513A					
°C	-30	-20	-10	0	10	20
20	50	53	55	40	-	-
40	54	57	61	64	67	63
60	50	55	59	63	67	71
80	34	39	45	50	55	60

$t_c \setminus t_o$	R744 (see Note)					
°C	-40	-30	-20	-10	0	10
-10	198	199	181	-	-	-
-5	204	206	206	124	-	-
0	209	211	211	179	-	-
5	-	214	214	213	120	-

$t_c \setminus t_o$	R1233zd(E)					
°C	30	40	50	60	70	80
60	19	-	-	-	-	-
80	49	51	52	31	-	-
100	50	54	57	60	63	51
120	46	50	54	58	62	66

$t_c \setminus t_o$	R1234yf <sup>1)</sup>					
°C	-30	-20	-10	0	10	20
20	44	46	49	32	-	-
40	46	49	52	56	59	53
60	41	45	49	53	57	61
80	24	29	34	39	44	49

$t_c \setminus t_o$	R1234ze(E) <sup>1)</sup>					
°C	-30	-20	-10	0	10	20
20	42	45	37	-	-	-
40	47	50	53	56	59	49
60	47	51	55	59	62	66
80	37	42	47	52	57	62

**Note**

- Correction table with: superheat R744 = 2 K      subcooling R744 = 1 K
- For R744:       $\Delta p$  upstream of evaporator = 0,1 bar
- For all refrigerants (except R744):       $\Delta p$  upstream of evaporator = 1.6 bar
- $\Delta p$  condenser = 0.3 bar       $\Delta p$  evaporator = 0.3 bar

<sup>1)</sup> For refrigerants belonging to Fluid group 1 (flammable), please contact your local Siemens representative.

The control valve throttles the capacity of a compressor stage. The hot gas passes directly to the evaporator, thus permitting capacity control in the range from 100% down to approximately 0%.

**Indirect hot-gas bypass application**

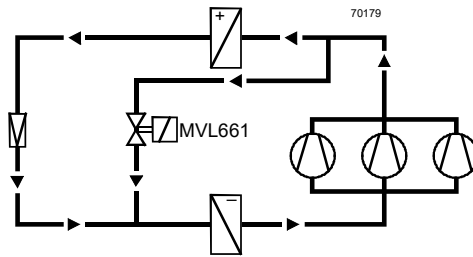

Suitable for use in large refrigeration systems in air conditioning plant, to prevent unacceptable temperature fluctuations between the compressor stages.

**Application example**

With low loads, the evaporating and condensing pressures can fluctuate depending on the type of pressure control. In such cases, evaporating pressure increases and condensing pressure decreases. Due to the reduction in differential pressure across the fully open valve, the volumetric flow rate will drop – the valve is undersized. This is why the effective pressures must be taken into account when sizing the valve for low loads.

Refrigerant R448A; 3 compressor stages;  $Q_o = 160 \text{ kW}$ ;  $t_o = -15 \text{ }^\circ\text{C}$ ;  $t_c = 50 \text{ }^\circ\text{C}$   
 Part load  $Q_o$  per stage =  $55 \text{ kW}$ ;  $t_o = -15 \text{ }^\circ\text{C}$ ;  $t_c = 45 \text{ }^\circ\text{C}$

KH R448	$t_o = -20 \text{ }^\circ\text{C}$	$t_o = -10 \text{ }^\circ\text{C}$	Interpolation at	$t_c = 45 \text{ }^\circ\text{C}$
$t_c = 40 \text{ }^\circ\text{C}$	25	25	$25 + [(38 - 25) \times (45 - 40) / (60 - 40)]$	25.25
$t_c = 45 \text{ }^\circ\text{C}$	-	-		
$t_c = 60 \text{ }^\circ\text{C}$	38	36	$25 + [(36 - 25) \times (45 - 40) / (60 - 40)]$	27.75

  

Interpolation at	$t_o = 4 \text{ }^\circ\text{C}$
$28.25 - [(28.25 - 27.75) \times (-20 - \{-15\}) / ((-20 - \{-10\})]$	28.00

$k_{vs}$  theoretical =  $55 \text{ kW} / 28.00 = 3 \text{ m}^3/\text{h} = 1.96 \text{ m}^3/\text{h}$   
 Valve MVL661.20-2.5 is suitable, since:  $1.96 \text{ m}^3/\text{h} / 2.5 \text{ m}^3/\text{h} \times 100 \% = 78 \% (> 40 \%)$

**Direct hot-gas bypass application**

The control valve throttles the capacity of one compressor stage. The gas is fed to the suction side of the compressor and then cooled using a reinjection valve. Capacity control ranges from 100% down to approximately 10%.

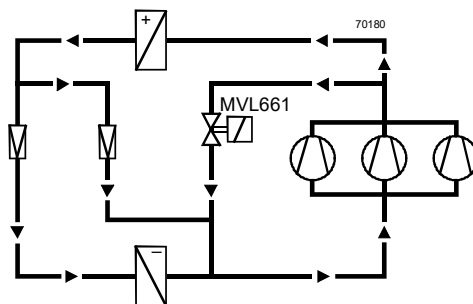

Suitable for large refrigeration systems in air conditioning applications with several compressors or compressor stages, and where the evaporator and compressor are some distance apart (attention must be paid to the oil return).



**Correction table KH**

Hot-gas valve  
Condenser Bypass

t <sub>c</sub> \ t <sub>o</sub> °C	R32 <sup>1)</sup>					
	-30	-20	-10	0	10	20
0	17	16	8.2	-	-	-
20	30	30	29	28	20	-
40	-	-	46	45	44	42
60	-	-	-	-	-	61

t <sub>c</sub> \ t <sub>o</sub> °C	R134a					
	-30	-20	-10	0	10	20
20	9.9	9.7	9.3	7.5	-	-
40	16	15	15	15	15	13
60	24	23	23	22	22	21
80	-	-	32	31	30	29

t <sub>c</sub> \ t <sub>o</sub> °C	R290 <sup>1)</sup>					
	-40	-30	-20	-10	0	10
0	11	10	0	-	-	-
20	18	18	20	17	15	-
40	28	27	40	26	25	25
60	40	39	60	36	36	35

t <sub>c</sub> \ t <sub>o</sub> °C	R448A					
	-40	-30	-20	-10	0	10
0	9.6	9.2	7.3	-	-	-
20	17	16	16	15	14	8,5
40	27	26	25	25	24	24
60	-	-	38	36	35	34

t <sub>c</sub> \ t <sub>o</sub> °C	R449A					
	-40	-30	-20	-10	0	10
0	9.5	9.1	7.2	-	-	-
20	16	16	16	15	14	8,3
40	27	26	25	24	24	23
60	-	-	37	36	34	34

t <sub>c</sub> \ t <sub>o</sub> °C	R450A					
	-30	-20	-10	0	10	20
20	8.3	8.2	7.6	5.5	-	-
40	13	13	13	13	12	11
60	20	20	19	19	19	18
80	28	27	26	26	25	25

t <sub>c</sub> \ t <sub>o</sub> °C	R452A					
	-40	-30	-20	-10	0	10
0	9,1	8,8	7,3	-	-	-
20	15	15	14	14	13	8,2
40	23	23	22	22	21	21
60	-	-	-	30	29	28

t <sub>c</sub> \ t <sub>o</sub> °C	R452B <sup>1)</sup>					
	-30	-20	-10	0	10	20
0	14	13	-	-	-	-
20	25	24	24	22	15	-
40	-	38	37	36	35	34
60	-	-	-	-	-	49

t <sub>c</sub> \ t <sub>o</sub> °C	R454B <sup>1)</sup>					
	-30	-20	-10	0	10	20
0	14	13	-	-	-	-
20	25	24	24	22	15	-
40	-	38	37	36	35	33
60	-	-	-	-	-	49

t <sub>c</sub> \ t <sub>o</sub> °C	R513A					
	-30	-20	-10	0	10	20
20	9.6	9.4	9.1	7.5	-	-
40	15	14	14	14	14	13
60	22	21	21	20	20	20
80	-	-	27	26	26	25

t <sub>c</sub> \ t <sub>o</sub> °C	R1233zd(E)					
	30	40	50	60	70	80
60	4.5	-	-	-	-	-
75	8.6	8.4	7.1	-	-	-
90	11	11	11	11	9,3	-
105	14	14	14	14	14	13

t <sub>c</sub> \ t <sub>o</sub> °C	R1234yf <sup>1)</sup>					
	-30	-20	-10	0	10	20
20	8.7	8.5	8.2	6.6	-	-
40	13	13	13	12	12	11
60	19	18	18	18	17	17
80	24	23	22	22	22	21

t <sub>c</sub> \ t <sub>o</sub> °C	R1234ze(E) <sup>1)</sup>					
	-30	-20	-10	0	10	20
20	7.1	6.8	6.1	-	-	-
40	11	11	11	11	10	9
60	17	17	16	16	16	16
80	24	23	23	22	22	21

- Correction table with: superheat = 6 K    subcooling = 2 K    Δp upstream of evaporator = 1.6 bar
- Δp condenser = 0.3 bar    Δp evaporator = 0.3 bar

<sup>1)</sup> For refrigerants belonging to Fluid group 1 (flammable), please contact your local Siemens representative.

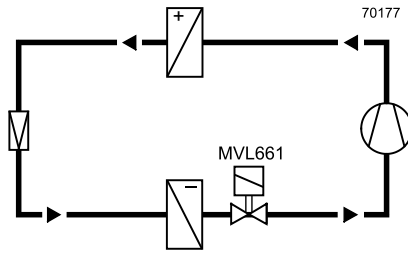

Typical control range 50...100%.

Minimum stroke limit control:

To ensure optimum cooling of the compressor, either a capacity controller must be provided for the compressor, or a minimum stroke must be set via the valve electronics.

The minimum stroke can be limited to a maximum of 80%. At zero load, the minimum stroke must be sufficient to ensure that the minimum gas velocity in the suction line is > 0.7 m/s and that the compressor is adequately cooled.

As the control valve closes, the evaporating temperature rises and the air cooling effect decreases continuously. The electronic control system provides demand-based cooling without unwanted dehumidification and costly retreatment of the air.

The pressure at the compressor inlet falls and the power consumption of the compressor is reduced. The energy savings to be anticipated with low loads can be determined from the compressor selection chart (power consumption at minimum permissible suction pressure). Compressor energy savings of up to 40% can be achieved.

**The recommended differential pressure  $\Delta p_{V100}$  across the fully open control valve is between  $0.06 < \Delta p_{V100} < 0.7$  bar. At the same time, the optimum pressure difference can be selected for each refrigerant and the related application.**

**Application example**

Refrigerant R513A;  $Q_o = 10$  kW;  $t_o = -8$  °C;  $t_c = 45$  °C;  
 Differential pressure across MVL661:  $\Delta p_{V100} = 0.13$  bar

In this application example,  $t_o$ ,  $t_c$  and  $\Delta p_{V100}$  are to be interpolated.

KS R513A	$t_c$	$t_o = -10$ °C	$t_o = 0$ °C
$\Delta p_{V100}$			
0.06 bar	20°C	<b>1.1</b>	<b>1.3</b>
0.06 bar	60°C	<b>0.66</b>	<b>0.85</b>
0.3 bar	20°C	<b>2.2</b>	<b>2.9</b>
0.3 bar	60°C	<b>1.3</b>	<b>1.8</b>

Interpolation at	$t_o = -8$ °C
$1.1 + [(1.3 - 1.1) \times (-10 - \{-8\}) / (-10 - 0)]$	1.14
$0.66 + [(0.85 - 0.66) \times (-10 - \{-8\}) / (-10 - 0)]$	0.698
$2.2 + [(2.9 - 2.2) \times (-10 - \{-8\}) / (-10 - 0)]$	2.34
$1.3 + [(1.8 - 1.3) \times (-10 - \{-8\}) / (-10 - 0)]$	1.40

$\Delta p_{V100}$	$t_o$	$t_c = 20$ °C	$t_c = 60$ °C
0.06 bar	-8°C	1.14	0.698
0.3 bar	-8°C	2.34	1.4

Interpolation at	$t_c = 45$ °C
$1.14 - [(1.14 - 0.698) \times (45 - 20) / (60-20)]$	0.864
$2.34 - [(2.34 - 1.4) \times (45 - 20) / (60-20)]$	1.753

$t_c$	$t_o$	$\Delta p_{V100}$	$\Delta p_{V100}$
-	-	0.06bar	0.3bar
45 °C	-8 °C	0.864	1.753

Interpolation at	$\Delta p_{V100}$
$0.864 + [(1.753 - 0.864) \times (0.13 - 0.06) / (0.3 - 0.06)]$	2.5

$k_{vs}$  theoretical = 10 kW / 1.123 kW / m<sup>3</sup>/h = 8.9 m<sup>3</sup>/h

Valve MVL661.25-6.3 is suitable, since 8.9 m<sup>3</sup>/h / 10 m<sup>3</sup>/h x 100 % = 89 % (> 40 %)

It is recommended that the  $k_{vs}$  value be set to 63 % = 4 m<sup>3</sup>/h eingestellt.

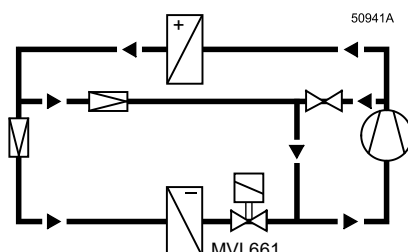

Typical control range 10...100%.

The capacity controller ensures that the compressor is adequately cooled, making it unnecessary to set a minimum stroke in the refrigerant valve.

**Correction table KS**  
Suction throttle valve

$\Delta p_{v100}$ bar	$t_c$ °C	R32 <sup>1)</sup>					
		-30	-20	-10	0	10	20
0.2	20	2.8	3.5	4.3	5.1	6.1	-
0.2	55	-	-	3.2	3.8	4.5	5.3
0.7	20	4.6	6.1	7.6	9.3	11.1	-
0.7	55	-	-	5.7	6.9	8.3	9.8

$\Delta p_{v100}$ bar	$t_c$ °C	R134a					
		-30	-20	-10	0	10	20
0.06	20	0.69	0.90	1.1	1.4	-	-
0.06	60	0.43	0.57	0.75	0.95	1.1	1.4
0.3	20	1.1	1.7	2.3	3.0	-	-
0.3	60	0.99	1.1	1.5	2.0	2.5	3.1

$\Delta p_{v100}$ bar	$t_c$ °C	R290 <sup>1)</sup>					
		-40	-30	-20	-10	0	10
0.07	20	1.0	1.3	1.6	2.0	2.4	-
0.07	60	0.62	0.82	1.0	1.3	1.6	1.9
0.4	20	1.9	2.7	3.6	4.5	5.6	-
0.4	60	1.1	1.5	2.2	2.9	3.7	4.5

$\Delta p_{v100}$ bar	$t_c$ °C	R448A					
		-40	-30	-20	-10	0	10
0.07	20	0.78	1.0	1.3	1.6	2.0	2.4
0.07	60	0.49	0.62	0.81	1.0	1.2	1.5
0.4	20	1.4	2.1	2.8	3.6	4.6	5.6
0.4	60	0.83	1.2	1.7	2.3	2.9	3.6

$\Delta p_{v100}$ bar	$t_c$ °C	R449A					
		-40	-30	-20	-10	0	10
0.07	20	0.78	1.0	1.3	1.6	2.0	2.4
0.07	60	0.45	0.61	0.80	1.0	1.2	1.5
0.4	20	1.3	2.0	2.8	3.6	4.5	5.6
0.4	60	0.81	1.2	1.7	2.2	2.9	3.6

$\Delta p_{v100}$ bar	$t_c$ °C	R450A					
		-30	-20	-10	0	10	20
0.06	20	0.61	0.81	1.0	1.3	-	-
0.06	60	0.37	0.50	0.66	0.85	1.0	1.3
0.3	20	1.0	1.5	2.0	2.7	-	-
0.3	60	0.60	0.95	1.3	1.7	2.2	2.8

$\Delta p_{v100}$ bar	$t_c$ °C	R452A					
		-40	-30	-20	-10	0	10
0.07	20	0.70	0.92	1.1	1.4	1.8	2.2
0.07	60	0.33	0.46	0.62	0.80	1.0	1.2
0.4	20	1.3	1.9	2.5	3.3	4.1	5.1
0.4	60	0.63	0.96	1.3	1.8	2.3	2.9

$\Delta p_{v100}$ bar	$t_c$ °C	R452B <sup>1)</sup>					
		-30	-20	-10	0	10	20
0.2	20	2.3	2.9	3.6	4.4	5.2	-
0.2	60	-	1.9	2.4	2.9	3.5	4.1
0.7	20	3.8	5.0	6.4	7.8	9.5	-
0.7	60	-	3.3	4.2	5.2	6.3	7.5

$\Delta p_{v100}$ bar	$t_c$ °C	R454B <sup>1)</sup>					
		-30	-20	-10	0	10	20
0.2	20	2.3	3.0	3.6	4.4	5.2	-
0.2	60	-	1.9	2.4	2.9	3.5	4.2
0.7	20	3.8	5.0	6.4	7.9	9.5	-
0.7	60	-	3.3	4.2	5.3	6.4	7.6

$\Delta p_{v100}$ bar	$t_c$ °C	R513A					
		-30	-20	-10	0	10	20
0.06	20	0.66	0.87	1.1	1.3	-	-
0.06	60	0.37	0.51	0.66	0.85	1.0	1.3
0.3	20	1.2	1.7	2.2	2.9	-	-
0.3	60	0.68	1.0	1.3	1.8	2.3	2.8

$\Delta p_{v100}$ bar	$t_c$ °C	R1233zd(E)					
		30	40	50	60	70	80
0.06	80	0.81	1.0	1.2	1.4	-	-
0.06	120	0.46	0.6	0.75	0.94	1.1	1.3
0.3	80	1.6	2.0	2.5	3.1	-	-
0.3	120	0.92	1.2	1.5	2.0	2.4	3.0

$\Delta p_{v100}$ bar	$t_c$ °C	R1234yf <sup>1)</sup>					
		-30	-20	-10	0	10	20
0.06	20	0.62	0.81	1.0	1.2	-	-
0.06	60	0.32	0.44	0.59	0.76	0.97	1.2
0.3	20	1.1	1.5	2.1	2.7	-	-
0.3	60	0.59	0.88	1.2	1.6	2.0	2.6

$\Delta p_{v100}$ bar	$t_c$ °C	R1234ze(E) <sup>1)</sup>					
		-30	-20	-10	0	10	20
0.06	20	0.54	0.73	0.94	-	-	-
0.06	60	0.32	0.45	0.59	0.77	0.98	1.2
0.3	20	-	1.3	1.8	-	-	-
0.3	60	-	0.80	1.1	1.5	2.0	2.6

- Correction table with: superheat = 6 K    subcooling = 2 K     $\Delta p$  upstream of evaporator = 1.6 bar
- $\Delta p$  condenser = 0.3 bar     $\Delta p$  evaporator = 0.3 bar

<sup>1)</sup> For refrigerants belonging to Fluid group 1 (flammable), please contact your local Siemens representative.

## Revision numbers

---

Product number	Valid from rev. no.
MVL661.15-0.4	C
MVL661.15-1.0	C
MVL661.20-2.5	D
MVL661.25-6.3	C
MVL661.32-10	A
MVL661.32-12	C

© Siemens Switzerland Ltd, 2011  
Technical specifications and availability subject to change without notice.