

Model IMV30 I/A Series® Multivariable Transmitters for Pressure, Differential Pressure, and Temperature Measurements with HART® Communication Protocol

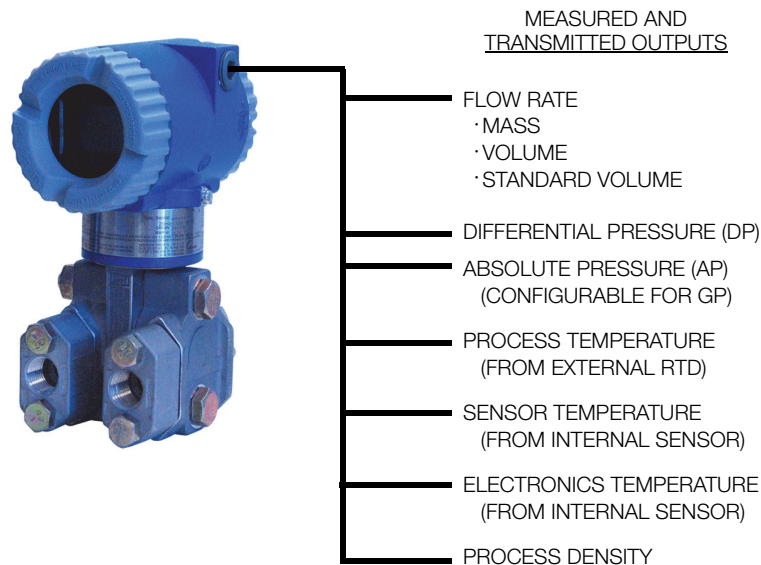

The Foxboro® brand Model IMV30 Multivariable Transmitter is available from Invensys. It is an intelligent two-wire transmitter that provides precise and reliable measurement of pressure, differential pressure, sensor and electronics temperatures, and process temperature (from an external RTD). It transmits a 4 to 20 mA or digital output signal, as applicable, using HART Communication for remote configuration, calibration, and monitoring. When used with a primary flow element, it also calculates process density and flow rate, and provides transmission of all the measured and calculated values.

FEATURES

- ▶ One transmitter for many applications:
 - Individual measurements on a 2-wire loop.
 - Multiple measurements digitally.
 - Assigns 4 to 20 mA to any measurement.
- ▶ Complete configuration using a Model PCMV PC-based configurator; limited configuration with optional LCD indicator, or HART communicator.
- ▶ Calculates mass, volume, or standard volume flow rate based on multiple measurements, using a primary flow element.
- ▶ Standard 5-year warranty.
- ▶ Convenient module change allows easy migration between communication protocols.
- ▶ Designed for hazardous area installations; versions available to meet agency flameproof and zone requirements.
- ▶ CE marked; complies with EMC, ATEX, and PED European Directives; and NAMUR NE 21 interference immunity requirement, and NAMUR 105 overrange and underrange annunciations.
- ▶ One transmitter replaces three separate transmitters, saving initial purchase costs.

BENEFITS

- ▶ Reduced process penetrations save money and reduce chances of fugitive emissions.
- ▶ Fewer transmitters, less wiring, and fewer shutoff valves reduce installation costs.
- ▶ Greater reliability due to fewer devices and less wiring means less chance of losses from downtime or process upsets.
- ▶ Flow rate values from the transmitter eliminate allocation of system resources for flow rate calculations, reducing system costs.
- ▶ High functionality and high performance provide exceptional value.
- ▶ Dual Seal certified by CSA to meet ANSI/ISA 12.27.01-2003 requirements.
- ▶ Numerous options and accessories offered to expand the capabilities of these transmitters.

I/A Series PRESSURE TRANSMITTER FAMILY

These transmitters are part of a complete family of gauge, absolute, d/p Cell®, multirange, multivariable, and premium performance transmitters, as well as transmitters with remote or direct mount pressure seals. They all use field-proven silicon strain gauge sensors and common topworks.

DIGITAL HART AND 4 TO 20 mA DC (VERSION -T ELECTRONICS)

4 to 20 mA with HART communications allows direct analog connection to common receivers while still providing full digital communications using a HART Communicator, PC-based configurator, or optional LCD indicator.

For complete configuration capability, Foxboro Model PCMV PC-based configurator is required. A HART Communicator PC-based configurator, or optional LCD indicator can be used for routine transmitter functions such as rezeroing or changing damping settings. See Figure 15 for more information on Option -L1, LCD indicator.

OPTIONAL CUSTOM FACTORY CONFIGURATION (OPTION -C2)

Changes can be made to the IMV30 using a HART Communicator, PC-based configurator, or the optional local display. These configuration methods cannot configure the IMV30 for a specific application, but can only modify some parameter values after the initial configuration. Therefore Invensys recommends that IMV30 transmitters be factory configured at time of shipment if the application information is known. In order to supply the necessary information to the factory, an Option -C2 Configuration Wizard must be run and the results must be available to BuyAutomation. If the Factory Configuration Option (Option -C2) is not selected in the Model Code, the user must then have Model PCMV configuration software to fully configure the IMV30 transmitter for flow rate applications. The Device Descriptions and Device Type Manager files available from Invensys can modify some configuration parameters, but only the Model PCMV will calculate the necessary coefficients related to the process liquid and pass them to the transmitter.

MULTIPLE MEASUREMENTS/CALCULATIONS

- ▶ Differential Pressure (DP)
- ▶ Pressure (P)
- ▶ Process Temperature (from external RTD)
- ▶ Flow Rate (Mass, Volume, or Standard Volume)
- ▶ Density
- ▶ Sensor Temperature
- ▶ Electronics Temperature

EXCEPTIONALLY HIGH PERFORMANCE

- ▶ Accuracy to $\pm 0.05\%$ of Span
- ▶ Long term stability with drift less than $\pm 0.05\%$ URL per year over a 5-year period
- ▶ Minimized static pressure effect on DP by using pressure to compensate the DP measurement
- ▶ Excellent Ambient Temperature Effect Compensation due to Characterization and Microprocessor-Based Compensation
- ▶ Total Probable Error (TPE) significantly better than typical competitive transmitters

FLOW RATE MEASUREMENT

- ▶ Can be used with primary flow devices such as orifice plates (see Figure 1), flow nozzles, Venturi tubes, and averaging pitot elements
- ▶ Flow equations for liquids, gases, and vapors (also natural gas and steam) reside in the IMV30
- ▶ With a separate RTD for Process Temperature Measurement, the IMV30 can calculate Mass Flow Rate, fully compensated for changes in absolute pressure and temperature
- ▶ Selection of Volume and Standard Volume Flow Rate, in addition to Mass Flow Rate
- ▶ Supports connection of a 2-, 3-, or 4-wire RTD, user-entered temperature, or calculation from saturation pressure (steam)
- ▶ Eliminates the need for a separate computer to make the flow rate calculations
- ▶ Flow rate transmission can be either in selectable EGU, such as kg/min (for the digital signal), or in Current (for the 4 to 20 mA analog signal), representing a specified flow rate range
- ▶ Continuous dynamic compensation for all variables, including:
 - Changes in fluid density
 - Dimensional changes in primary device and adjacent piping with temperature
 - Changes in discharge coefficient based on Reynolds Number (corrected for velocity, density, and viscosity)

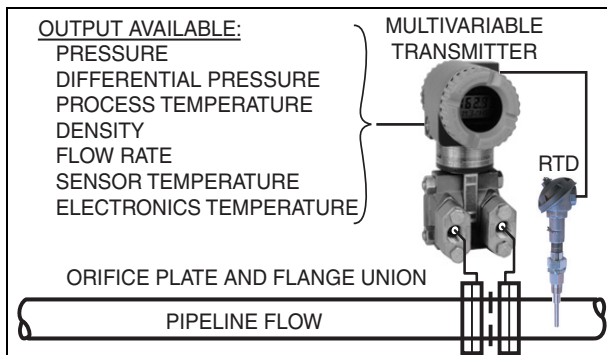

Figure 1. Flow Rate Measurement with Orifice Plate

MODEL PCMV MULTIVARIABLE TRANSMITTER CONFIGURATOR

Refer to PSS 2A-1Z3 F.

- ▶ Windows-based software package to configure IMV30 Transmitter for flow rate applications
- ▶ Determines a set of application-specific coefficients to be downloaded to transmitter for use in the transmitter's flow rate equations
- ▶ Provides configuration for:
 - Choice of primary flow device (i.e., orifice, nozzle, Venturi, averaging pitot)
 - Choice of pressure tap location (i.e., flange, corner, or D and D/2)
 - Process fluid, from a database of density-temperature relationships for over 275 fluids, or from user-entered density and temperature data
 - Operating pressure and temperature ranges
 - Industry flow rate standards, such as AGA, API, ISO, and ASME
- ▶ Easy-to-use configurator provides selections for user applications. For typical configurator screens, see Figures 2 to 4.

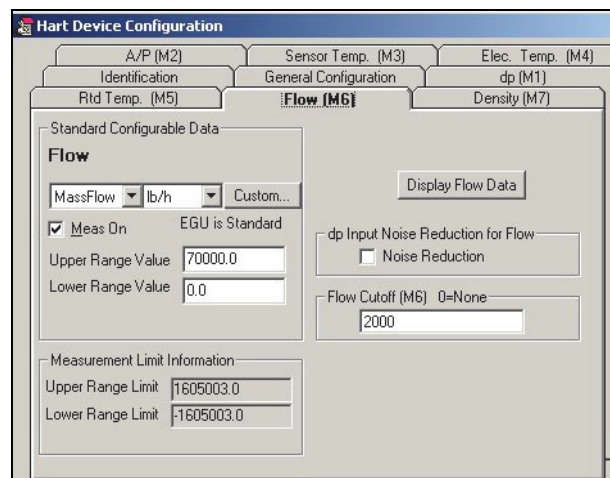

Figure 2. HART Device Configuration Screen

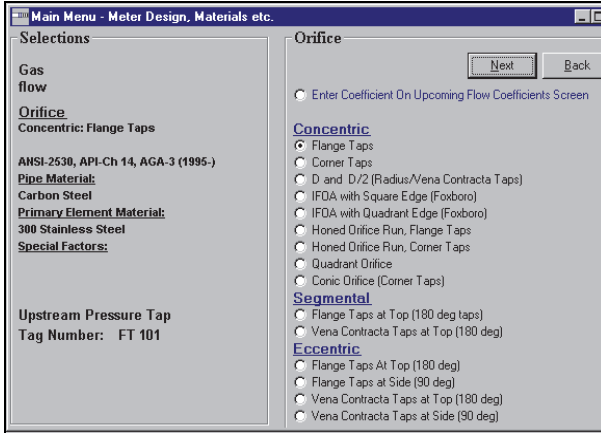

Figure 3. Orifice Plate Type Selection Screen

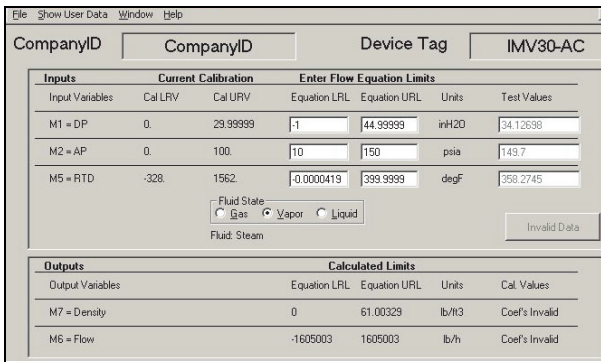

Figure 4. Model PCMV User Data Screen

ANALOG OR DIGITAL TRANSMISSION

- ▶ The 4 to 20 mA analog output can be assigned to any one of the following variables:
 - Differential Pressure
 - Absolute Pressure
 - Process Temperature
 - Sensor Temperature
 - Electronics Temperature
 - Flow Rate
 - Density (at actual pressure and temperature, and based on known fluid parameters)

Also, these variables can be read digitally using the Model PCMV PC-based Configurator or HART Communicator.

- ▶ The digital output can be used for direct communication with an I/A Series System FBM:
 - With HART protocol, the above listed variables are digitally communicated to the system FBM with a 4 to 20 mA current.
 - All of the variables may be read digitally using the Model PCMV PC-based Configurator or HART Communicator.

DIGITAL COMMUNICATION

See Figure 5.

- ▶ Digital integration – all communications between applicable I/A Series System fieldbus module (FBM) and transmitter are digital
- ▶ HART communications suitable for monitoring and control applications
- ▶ Measurements are in EGU for ease of use
- ▶ Continual monitoring of transmitter diagnostics
- ▶ Measurements communicated from transmitter lower range to upper range limit, regardless of calibrated range. This provides more flexibility and information and eliminates the need to rerange transmitters when conditions change
- ▶ Eliminates need for system analog input circuit, digital-to-analog conversion in the transmitter, and analog-to-digital conversion in the system, resulting in improved accuracy

EASE OF INSTALLATION

- ▶ Rotatable Topworks
 - Allows installation in tight places
 - Positions indicator in preferred direction
 - Eases field retrofit
- ▶ Two conduit connections
 - Provide for easy wiring
 - Allow self-draining of condensation
- ▶ Wiring guides and terminations
 - Provide easy entry and plenty of space
 - Use large, rugged screw terminals for easy wire termination

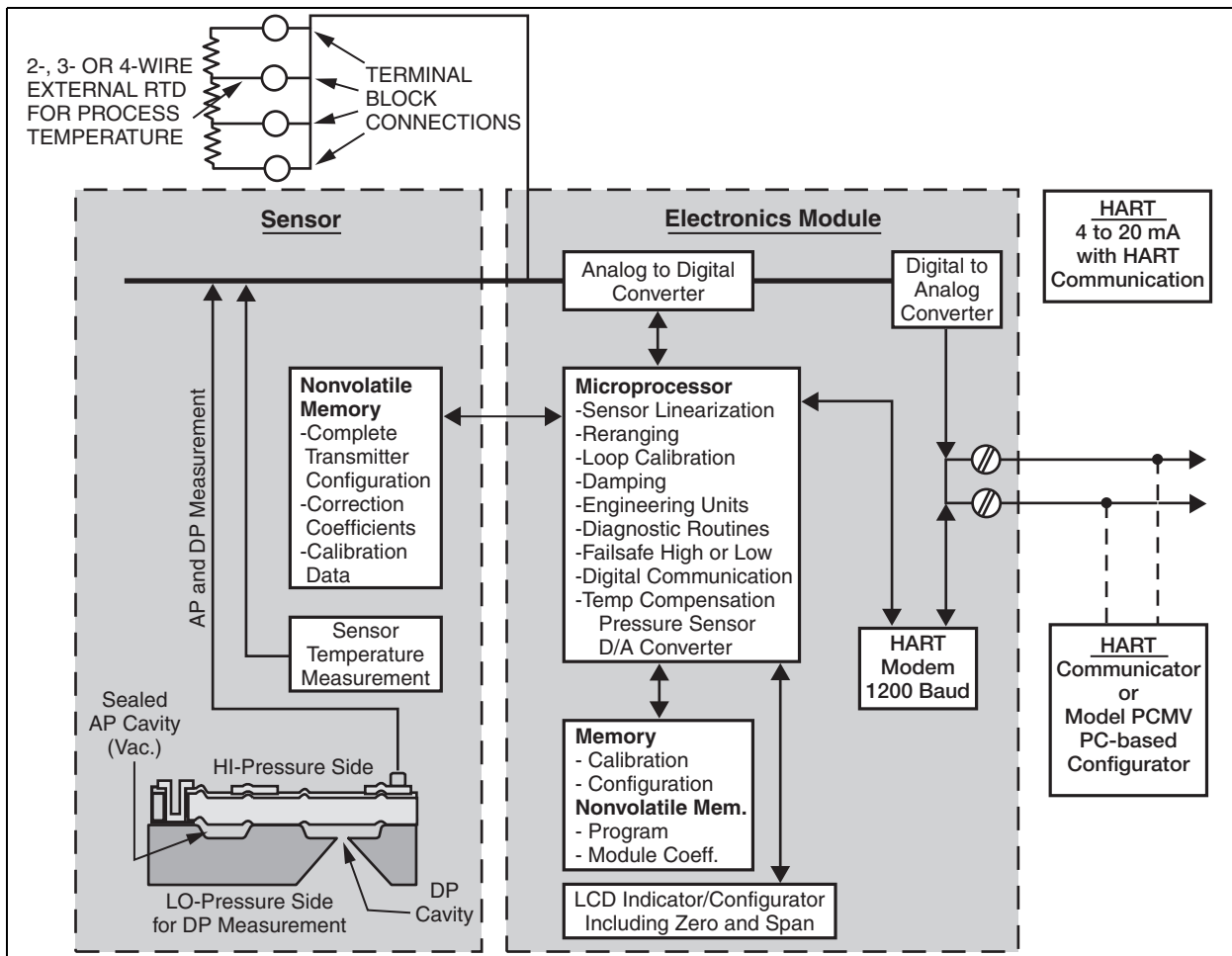

Figure 5. IMV30 HART Functional Block Diagram

PROCESS CONNECTORS

- ▶ Removable, gasketed connectors allow a wide range of selections, including 1/4 NPT, 1/2 NPT, Rc 1/4, Rc 1/2, and weld neck connectors.

OPTIONAL LCD DIGITAL INDICATOR

- ▶ A digital indicator (see Figure 15) with on-board pushbuttons is available to display the measurement with a choice of units.
- ▶ Pushbuttons allow zero and span adjustments, as well as routine local configuration changes.

UNIQUE PROCESS COVER AND CELL BODY DESIGN

Biplanar Construction (Figure 6) maintains the traditional horizontal process connections and vertical mounting by providing a cell body contained between two process covers, while still achieving light weight, small size, and high static pressure rating. This provides easy retrofit of any conventional differential pressure transmitter, and also is easily mounted in the horizontal position with vertical process connections, when required.

Process Covers (Figure 6) are fully supported by the cell body over their entire height. This prevents bending and results in a highly reliable seal. Also, this provides dimensional stability to the process covers, ensuring that they will always mate properly with 3-valve bypass manifolds.

Process Cover Bolts (Figure 6) are enclosed to minimize corrosion and to minimize early elongation with rapid temperature increases. The design makes it less likely for the transmitter to release process liquid during a fire.

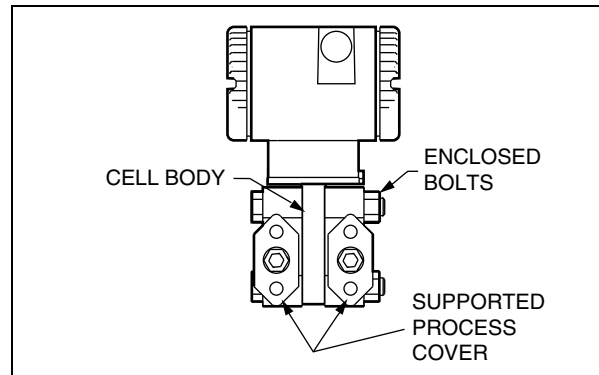

Figure 6. Biplanar Construction Shown with Traditional Horizontal Process Connections

Process Cover Gaskets are ptfе as standard; ptfе provides nearly universal corrosion resistance, and eliminates the need to select and stock various elastomers to assure process compatibility.

ATEX Flameproof Design allows transmitter to be installed in hazardous locations requiring ATEX Flameproof rating.

Light Weight provides ease of handling, installation, and direct mounting without requiring costly pipe stands.

TRADITIONAL STRUCTURE

The traditional structure (Figure 7) utilizes the right angle design common to most differential pressure transmitters in use throughout the world. Process connections are oriented 90 degrees from the transmitter centerline.

This traditional structure makes it easy to retrofit any transmitters of similar design.

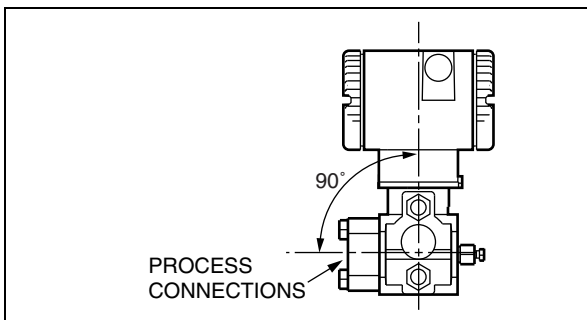

Figure 7. Vertical Mounting Showing Process Connections at 90 degrees

Sensor cavity venting and draining is provided for both vertical and horizontal transmitter installation, using innovative tangential connections to the sensor cavity (Figures 8 and 9). Optional side vents are offered for sensor cavity venting in the upright position (Figure 10).

An extensive variety of process-wetted materials are available for the process covers on this highly versatile and widely used transmitter.

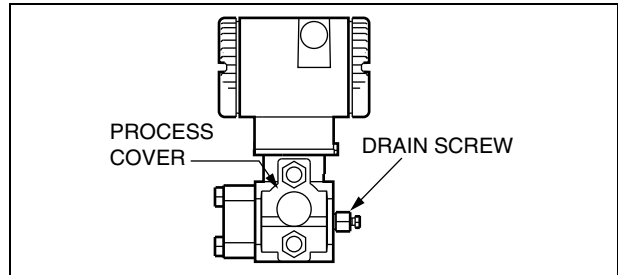

Figure 8. Vertical Mounting - Cavity Draining

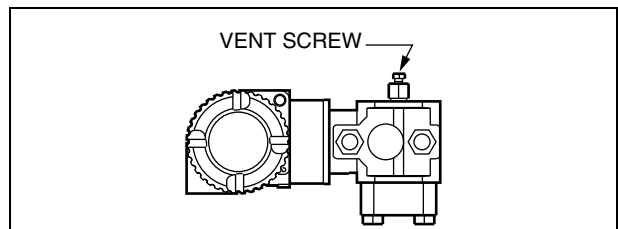

Figure 9. Horizontal Mounting - Cavity Venting and Self-Draining into Process Line

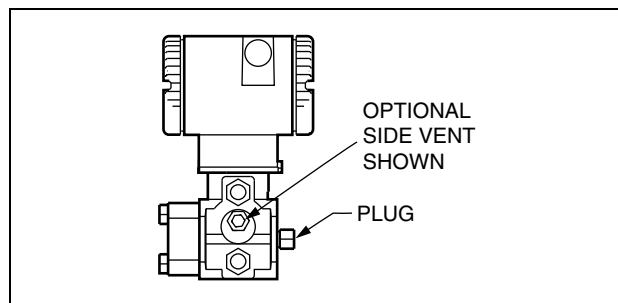

Figure 10. Vertical Mounting - Cavity Venting and Self-Draining into Process Line

FUNCTIONAL SPECIFICATIONS

Span and Range Limits for Differential Pressure Measurement

Span Code (a)	Span Limits			Range Limits (b)		
	kPa	inH ₂ O	mbar	kPa	inH ₂ O	mbar
L	0.12 and 2.5	0.5 and 10	1.2 and 25	-2.5 and +2.5	-10 and +10	-25 and +25
A	0.75 and 7.5	3 and 30	7.5 and 75	-7.5 and +7.5	-30 and +30	-75 and +75
B	0.5 and 50	2 and 200	5 and 500	-50 and +50	-200 and +200	-500 and +500
C	2.5 and 210	10 and 840	25 and 2100	-210 and +210	-840 and +840	-2100 and +2100

- (a) See maximum static, working, and range limits table below for available combinations of DP and AP span codes.
- (b) Positive values indicate HI side of sensor at the high pressure, and negative values indicate LO side of sensor at the high pressure.

Span and Range Limits for Absolute Pressure Measurement (a)

Span Code (b)	Span Limits			Range Limits		
	MPaa	psia	bara or kg/cm ² abs	MPaa	psia	bara or kg/cm ² abs
D	0.02 and 2.1	3 and 300	0.21 and 21	0 and 2.1	0 and 300	0 and 21
G	0.07 and 3.5	10 and 500	0.7 and 35	0 and 3.5	0 and 500	0 and 35
E	0.21 and 10	30 and 1500	2.1 and 100	0 and 10	0 and 1500	0 and 100
H	0.42 and 20	60 and 3000	4.2 and 200	0 and 20	0 and 3000	0 and 200
F	3.4 and 36.5	500 and 5300	34 and 365	0 and 36.5	0 and 5300	0 and 365

- (a) Absolute Pressure measured directly; Gauge Pressure calculated from user-entered barometric pressure constant.
- (b) See maximum static, working, and range limits table below for available combinations of DP and AP span codes.

Sensor URL, Maximum Static and Working Pressure (MWP), and Maximum Overrange Pressure

Allowable Span Code Combinations DP and AP	Sensor URL (DP and AP)				Maximum Static and Working Pressure (MWP)		Maximum Overrange Pressure	
	DP	AP	DP	AP	MPaa	psia	MPaa	psia
L and G	10 inH ₂ O	500 psia	2.5 kPa	3.4 MPaa	3.5	500	5.2	750
A and G	30 inH ₂ O	500 psia	7.5 kPa	3.4 MPaa	3.5	500	5.2	750
B and D	200 inH ₂ O	300 psia	50 kPa	2.1 MPaa	2.1	300	3.1	450
B and E	200 inH ₂ O	1500 psia	50 kPa	10 MPaa	10	1500	15	2250
B and H	200 inH ₂ O	3000 psia	50 kPa	20 MPaa	20	3000	30	4500
B and F	200 inH ₂ O	5300 psi	50 kPa	36.5 MPaa	36.5	5300	51.2	7420
C and D	840 inH ₂ O	300 psia	210 kPa	2.1 MPaa	2.1	300	3.1	450
C and E	840 inH ₂ O	1500 psia	210 kPa	10 MPaa	10	1500	15	2250
C and H	840 inH ₂ O	3000 psia	210 kPa	20 MPaa	20	3000	30	4500
C and F	840 inH ₂ O	5300 psia	210 kPa	36.5 MPaa	36.5	5300	51.2	7420

Impact of Certain Options on Maximum Static Pressure and Span and Range Limits (a) (b)

Option	Description (Also see Model Code)	Span and Range Limits Derated to:
-B3	B7M Bolts and Nuts (NACE)	20 MPaa (2900 psia, 200 bara or kg/cm ² abs)
-D1	DIN Construction	16 MPaa (2320 psia, 160 bara or kg/cm ² abs)
-D5 or -B1	DIN Construction or 316 ss Bolting	15 MPaa (2175 psia, 150 bara or kg/cm ² abs)
-D2, -D4, -D6, or -D8	DIN Construction	10 MPaa (1500 psia, 100 bara or kg/cm ² abs)

- (a) Refer to Model Code section for application and restrictions related to the items listed in the table.
- (b) There is no impact (derating) when Options -B2, -D3, or -D7 are selected. The ratings for these options are the standard rating of 25 MPaa (3625 psia, 250 bara, or kg/cm² abs).

Output Signal and Configuration

4 to 20 mA with HART Communications. When configured for multidrop applications, the mA signal is fixed at 4 mA to provide power to the device. Configurable with a HART Communicator, Model PCMV Configurator, or optional LCD indicator. Model PCMV required for flow rate applications.

Measured and Transmitted Outputs

- ▶ Absolute Pressure (Configurable for Gauge Pressure)
- ▶ Differential Pressure
- ▶ Sensor Temperature
- ▶ Electronics Temperature
- ▶ Process Temperature (from External RTD)

Calculated⁽¹⁾ and Transmitted Outputs

- ▶ Process Density - Flowing Conditions
- ▶ Mass Flow Rate
- ▶ Volume Flow Rate - Flowing Conditions
- ▶ Volume Flow Rate at Base Conditions - e.g., Standard ft³/h (SCFH), or Normal m³/h (NCMH)

Supply Voltage

HART 4 to 20 mA output with a superimposed digital signal. Minimum supply voltage is 11.5 V dc (Figure 11).

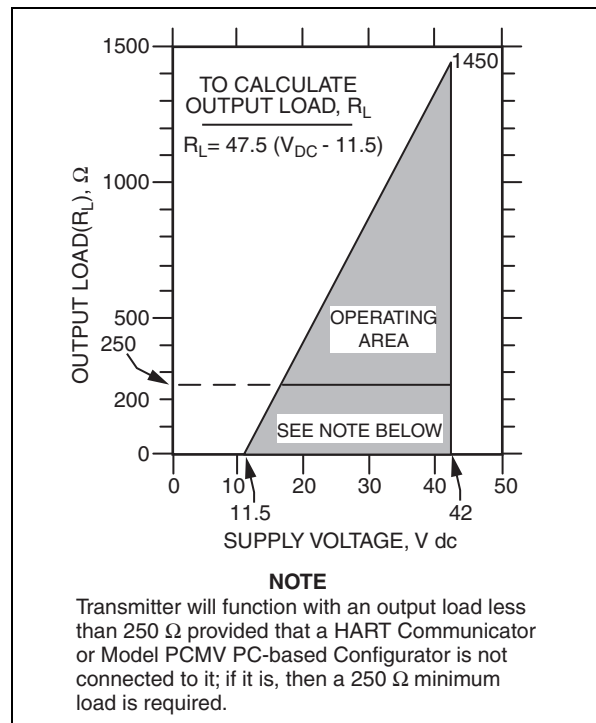

Figure 11. 4 to 20 mA Output, Supply Voltage vs. Output Load

(1) Density and Flow Equations used for the calculated outputs, and Flow Terminology, are from R. W. Miller's *Flow Measurement Engineering Handbook*, available from Invensys by specifying Part Number B0150YW.

Adjustable Damping (DP and Pressure)

The transmitter response time is normally 1.0 s, or the electronically adjustable setting of 0.00 (none), 0.25, 0.50, 1, 2, 4, 8, 16, or 32 seconds, whichever is greater, for a 90% recovery from an 80% input step as defined in ANSI/ISA S51.1.

Zero and Span Adjustments

Zero and span adjustments can be initiated from the Model PCMV or the optional LCD indicator.

Suppressed Zero and Elevated Zero

Suppressed or elevated zero ranges are acceptable provided Span and Range Limits are not exceeded.

Zeroing for Nonzero-Based Ranges

Dual Function Zeroing from the LCD indicator pushbuttons allows differential pressure zeroing with either zero differential or LRV differential applied. This greatly simplifies position effect zeroing on many pressure and level applications. The PC-based configurator or HART Communicator provides zeroing at any user-entered value.

Current Outputs for Overrange, Fail, and Offline Conditions

Parameter	HART
OFFLINE	User configurable between 4 and 20 mA
SENSOR FAILURE	User configurable to Fail LO or Fail HI
FAIL LO	3.60 mA
UNDERRANGE	3.80 mA
OVERRANGE	20.50 mA
FAIL HI	21.00 mA

Write Protect Jumper

Can be positioned to lock out all configurators from making transmitter database changes. This makes transmitter suitable for safety shutdown system applications that require this feature.

Field Wiring Reversal

No transmitter damage.

Minimum Allowable Absolute Pressure vs. Transmitter Temperature

- ▶ **With Silicone Fill Fluid**
Full vacuum: up to 121 °C (250 °F)
- ▶ **With Inert Fill Fluid**
Refer to Figure 12.

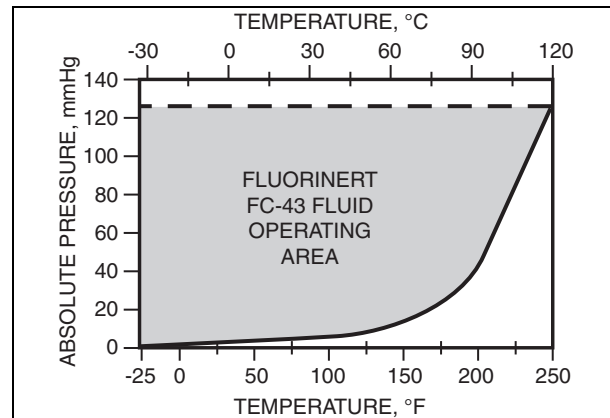

Figure 12. Minimum Allowable Absolute Pressure vs. Transmitter Temperature, Inert FC-43, 2.6 cs at 25°C (77°F)

Process Temperature Measurement and Limits

- ▶ **Measurement:** DIN/IEC, 2-, 3-, or 4-wire, 100 ohm, Platinum RTD
- ▶ **Range Limits:** -200 and +850°C (-328 and +1562°F)

Flow Cutoff and Low Differential Pressure (DP)

When configured for flow rate calculations, Flow Cutoff Value may be entered in flow units, and Noise Reduction may be set “OFF” or “ON”, where:

- OFF = Flow Rate calculated from square root of DP
- ON = Flow Rate calculated from dual slope linear DP below 4% of maximum configured DP

When configured as a standard DP transmitter in square root mode, it may be set for cutoff-to-zero for DP < 1% of maximum DP, or Dual Slope Linear for DP < 4% of maximum DP.

Communications

HART available in analog or multidrop mode. Digital communication is provided in all modes based upon the FSK technique which alternately superimposes one of two different frequencies on the uninterrupted current carried by the two signal/power wires. See Table 1 and Figures 13 to 14.

Table 1. Communication Parameters

Parameter	HART Analog Mode 4 to 20 mA	HART Multidrop Mode Fixed Current (a)
Configurator/Communicator	HART Communicator, or Model PCMV Configurator (b)	
Communication Rate	1200 baud	1200 baud
Communication Distance (Rated)	3050 m (10 000 ft)	1525 m (5000 ft)

- (a) Multidrop mode supports communication with up to 15 transmitters on a single pair of signal/power wires.
- (b) Model PCMV Multivariable Transmitter Configurator required for flow rate configuration.

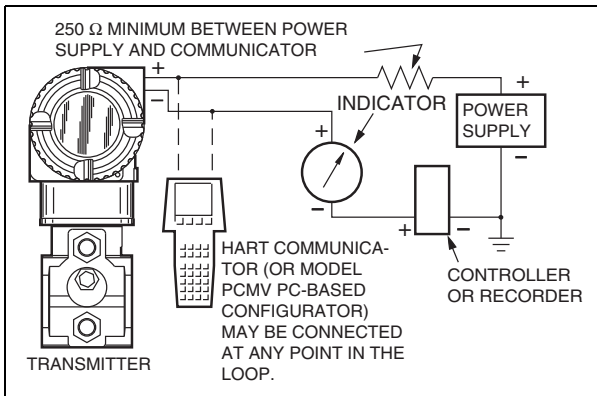

Figure 13. HART 4 to 20 mA Topology

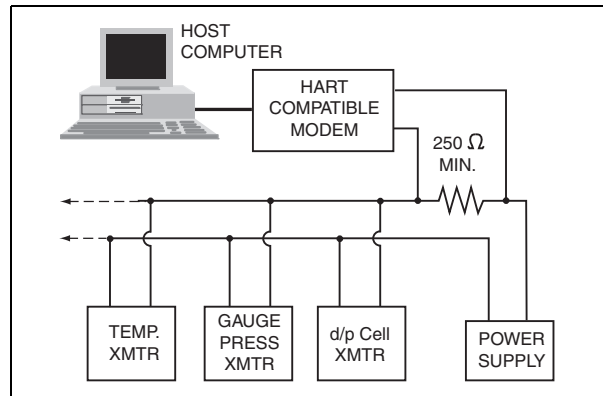

Figure 14. HART Multidrop Topology

Configuration and Calibration Data, and Electronics Upgradeability

All factory characterization data, and user configuration and calibration data, are stored in the sensor. This means that the electronics module can be replaced or changed from one type to another.

A module may be replaced without the need for reconfiguration or recalibration. Although module replacement can affect accuracy up to 0.20% of span, this error can be removed by an mA trim without application of pressure.

Changing module types may require reconfiguration and recalibration, as well as a different terminal block, if applicable, but all factory characterization data is retained.

Configuration Capability (a)

Variable	Measurement
Primary Variable	Differential Pressure (DP)
Secondary Variable	Absolute Pressure (AP)
Tertiary Variable	Process Temperature

(a) Numerous parameters can be configured and/or displayed, such as electronic damping, failsafe direction, transmitter calibration, tag data, etc. See applicable configuration documents for details.

Available Units for Calibrated Range

Pressure					Temp.
inH ₂ O	inHg	Pa	mbar	psi	C
ftH ₂ O	mmHg	kPa	bar	atm	F
mmH ₂ O		MPa	g/cm ²		R
mH ₂ O		torr	kg/cm ²		K

Option -C2: Optional Custom Configuration

For the transmitter to be custom configured by the factory, the user must complete the Multivariable Configuration Wizard before entering the order, this being the recommended procedure. If Option -C2 is not selected, a standard default configuration will be provided. The user will then need to completely configure the transmitter using the Model PCMV.

Option -L1: Optional Liquid Crystal Display (LCD) Digital Indicator with On-Board Pushbuttons (Figure 15)

Indicator provides:

- ▶ Two Lines; five numeric characters on top line (four when a minus sign is needed) and seven alphanumeric characters on bottom line.
- ▶ Measurement Readout; value displayed on top line, and units label displayed on bottom line.
- ▶ Configuration and Calibration Prompts.

Pushbuttons provide for:

- ▶ Configuration Functions⁽²⁾
- ▶ Calibration Functions

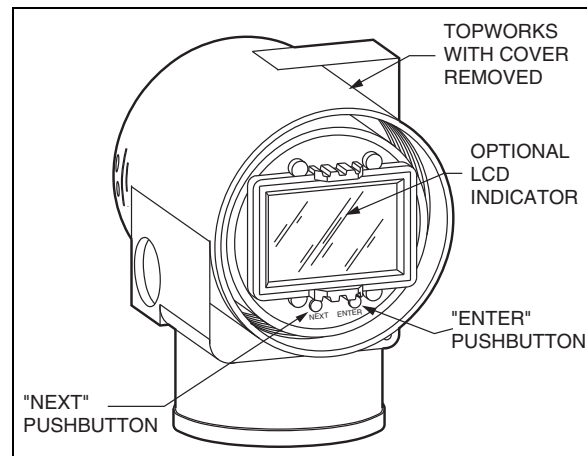

Figure 15. LCD Indicator with On-Board Pushbuttons

(2) Model PCMV Multivariable Transmitter Configurator required for flow rate configuration

OPERATING, STORAGE, AND TRANSPORTATION CONDITIONS

Influence	Reference Conditions	Normal Operating Conditions (a) (b)	Operative Limits (a) (b)	Transportation/Storage Limits
Sensor Body Temperature ▶ w/Silicone Fill Fluid	24 ± 2°C (75 ± 3°F)	-29 to + 82°C (-20 to +180°F)	-46 and +121°C (c) (-50 and +250°F) (c)	-54 and +85°C (-65 and +185°F)
▶ w/Inert Fill Fluid	24 ± 2°C (75 ± 3°F)	-29 to + 82°C (-20 to +180°F)	-29 and +121°C (-20 and +250°F)	-50 and +85°C (-58 and +185°F)
Electronics Temperature	24 ± 2°C (75 ± 3°F)	-29 to + 82°C (e) (-20 to +180°F) (e)	-40 and +85°C (e) (-40 and +185°F) (e)	-54 and +85°C (-65 and +185°F)
▶ with LCD Indicator (d)	24 ± 2°C (75 ± 3°F)	-20 to + 82°C (e) (-4 to +180°F) (e)	-29 and +85°C (e) (-20 and +185°F) (e)	-54 and +85°C (-65 and +185°F)
Relative Humidity (f)	50 ±10%	0 to 100%	0 and 100%	0 and 100% Noncondensing
Supply Voltage – mA Output	30 ± 0.5 V dc	11.5 to 42 V dc	11.5 and 42 V dc	Not Applicable
Output Load – mA Output	650 Ω	0 to 1450 Ω (g)	0 and 1450 Ω (g)	Not Applicable
Vibration	1 m/s ² (0.1 “g”)	6.3 mm (0.25 in) Double Amplitude: from 5 to 15 Hz with Aluminum Housing from 5 to 9 Hz with 316 ss Housing 0 to 30 m/s ² (0 to 3 “g”) from 15 to 500 Hz with Aluminum Housing; 0 to 10 m/s ² (0 to 1 “g”) from 9 to 500 Hz with 316 ss Housing		11 m/s ² (1.1 “g”) from 2.5 to 5 Hz (in Shipping Package)
Mounting Position	Upright or Horizontal (h)		No Limit	Not Applicable

- (a) When DIN Construction Options -D2/-D4/-D6/-D8 are used, temperature limits are 0 and 60°C (32 and 140°F).
- (b) Normal Operating Conditions and Operative Limits are defined per ANSI/ISA 51.1-1979 (R1993).
- (c) Selection of Option -J extends the low temperature operative limit of transmitters with silicone filled sensors down to -50°C (-58°F). Performance is not assured below -29°C. Sensor damage may occur if process is frozen.
- (d) Although the LCD will not be damaged at any temperature within the “Transportation/Storage Limits”, updates will be slowed and readability decreased at temperatures outside the “Normal Operating Conditions”.
- (e) Refer to the Electrical Safety Specifications section for a restriction in ambient temperature limits with certain electrical certifications.
- (f) With topworks cover on and conduit entrances sealed.
- (g) See Figure 11 for minimum load required for proper HART communication.
- (h) Sensor process wetted diaphragms in a vertical plane.

PERFORMANCE SPECIFICATIONS

Zero-Based Calibrations; Stainless Steel Sensor with Silicone Fluid; Under Reference Operating Conditions unless otherwise specified; URL = Upper Range Limit and Span = Calibrated Span

Accuracy (a) - Differential Pressure (b)

Span Codes	Accuracy in % of Span	
	Spans ≥10% URL	Spans <10% URL
B and C	±0.05	$\pm(0.005)\left(\frac{URL}{Span}\right)$
L and A	±0.10	$\pm(0.010)\left(\frac{URL}{Span}\right)$

- (a) Accuracy stated includes the effects of linearity, hysteresis, and repeatability.
- (b) Also add ±0.025% to the accuracy to determine the total analog output accuracy if the Differential Pressure measurement is assigned to the 4 to 20 mA output signal.

Accuracy (a) - Absolute Pressure (b) (c)

Span Codes	Accuracy in % of Span	
	Spans ≥10% URL	Spans <10% URL
D, E, H, and F	±0.05	$\pm(0.005)\left(\frac{URL}{Span}\right)$
	Spans ≥5% URL	Spans <5% URL
G	±0.05	$\pm(0.0025)\left(\frac{URL}{Span}\right)$

- (a) Accuracy stated includes the effects of linearity, hysteresis, and repeatability.
- (b) For gauge pressure accuracy, add anticipated variation from user-entered barometric pressure.
- (c) Also add ±0.025% to the accuracy to determine the total analog output accuracy if the Absolute Pressure measurement is assigned to the 4 to 20 mA output signal.

Accuracy - Process Temperature

±0.28°C (0.5°F) within ±140°C (250°F) of the normal operating point.

Accuracy - Flow Measurement

±1.0% of flow rate when configured for typical head class meter applications.

Stability (Long Term Drift)

< ±0.05% of URL per year over a 5-year period.

Calibration Frequency

The calibration frequency is five years. The five years is derived using the values of allowable error (% span), TPE (% span), performance margin (% span), and stability (% span/month); where:

$$\text{Calibration Frequency} = \frac{\text{Performance Margin}}{\text{Stability}} = \text{Months}$$

Power-up Time

Less than 5 seconds for output to reach first valid measurement.

Vibration Effect

±0.2% of URL per “g” for vibrations in the range of 5 to 500 Hz; with double amplitudes of 6.3 mm (0.25 in) in the range of 5 to 15 Hz, or accelerations of 3 “g” in the range of 15 to 500 Hz, whichever is smaller, for aluminum housings; and with double amplitudes of 6.3 mm (0.25 in) in the range of 5 to 9 Hz, or accelerations of 1 “g” in the range of 9 to 500 Hz, whichever is smaller, for 316 ss housings.

RFI Effect

The output error is less than 0.1% of span for radio frequencies in the range of 27 to 1000 MHz and field intensity of 30 V/m when the transmitter is properly installed with shielded conduit and grounding, and housing covers are in place. (Per IEC Std. 61000-4-3.)

Supply Voltage Effect

Output changes less than 0.005% of span for each 1 V change within the specified supply voltage requirements. See Figure 11.

PHYSICAL SPECIFICATIONS

Static Pressure Effect on Differential Pressure

The zero and span shift for a 0.7 MPa, 100 psi, change in static pressure is:

Zero Shift

Span Limit Code		Zero Shift for a 0.7 MPa (100 psi) Change:
DP	AP	in % of URL
L	G	±0.150
A	G	±0.050
B	D	±0.007
B	E	±0.010
B	H	±0.010
B	F	±0.010
C	D	±0.002
C	E	±0.004
C	H	±0.004
C	F	±0.004

Span Shift

±0.01% of Reading

Position Effect

Transmitter may be mounted in any position. Any zero effect caused by mounting position can be eliminated by rezeroing. There is no span effect.

Ambient Temperature Effect

Total effect for both absolute and differential pressure for a 28°C (50°F) change within Normal Operating Condition Limits is ±(0.03% URL + 0.06% Span); except the effect on differential pressure for DP Span Codes A and L is ±(0.18% URL + 0.025% Span). Also for AP Span Code H, the effect is ±(0.02% URL + 0.06% Span); and for AP Span Code F, the effect is ±(0.15% URL + 0.06% Span).

Electromagnetic Compatibility

- ▶ Complies with NAMUR NE 21 Interference Immunity Requirement, and NAMUR 105 overrange and underrange annunciations
- ▶ Complies with electromagnetic compatibility requirements of European EMC Directive 89/336/EEC by conforming to following CENELEC and IEC Standards: EN 50081-2, EN 50082-2, IEC 61000-4-2 through 61000-4-6

Switching and Indirect Lightning Transients

The transmitter can withstand a transient surge up to 2000 V common mode or 1000 V normal mode without permanent damage. Output shift is <1.0%. (Per ANSI/IEEE C62.41-1980 and IEC Std. 801-5.)

PHYSICAL SPECIFICATIONS

Process Cover and Connector Material (Process Wetted)

316 ss or nickel alloy (equivalent to Hastelloy® C⁽³⁾), as specified

Process Cover Bolts and Nuts

ASTM A193, Grade B7 high strength alloy steel for bolts, and ASTM A194 Grade 2H high strength alloy steel for nuts are standard. Options include NACE Class B7M bolting, 17-4 ss bolting, and 316 ss bolting. For the NACE B7M bolting option, refer to PSS 2A-1Z9 E.

Process Cover and Process Connection Gaskets

Glass filled ptfе (Chemloy)

Sensor Material (Process Wetted)

316L ss or nickel alloy (equivalent to Hastelloy® C), as specified

Sensor Fill Fluids

Silicone Oil or Fluorinert (FC-43)

(3) Hastelloy is a registered trademark of Haynes International, Inc.

Environmental Protection

Transmitter is dusttight and weather proof per IEC IP66 and provides the environmental and corrosion resistant protection of NEMA Type 4X.

Electronics Module

Printed wiring assemblies are conformally coated for moisture and dust protection.

Electronics Housing and Housing Covers

Housing has two compartments to separate the electronics from the field connections. The housing and covers are made from low copper, die-cast aluminum alloy with an epoxy finish, or from 316 ss. Buna-N O-ring seals are used to seal the threaded housing covers, housing neck, and terminal block.

Electrical Connections

Field and RTD sensor wires enter through 1/2 NPT, PG 13.5, or M20, threaded entrances, as specified, on either side of the electronics housing. Wires terminate under screw terminals and washers on terminal block in the field terminal compartment. Refer to Figure 16.

Mounting Position

The transmitter may be mounted in any orientation.

Approximate Mass

- 3.5 kg (7.8 lb) – without Process Connectors
- 4.2 kg (9.2 lb) – with Process Connectors
- Add 1.1 kg (2.4 lb) – with 316 ss Housing
- Add 0.2 kg (0.4 lb) – with LCD Indicator Option

Dimensions

See “DIMENSIONS - NOMINAL” on page 23 and Dimensional Print DP 020-432.

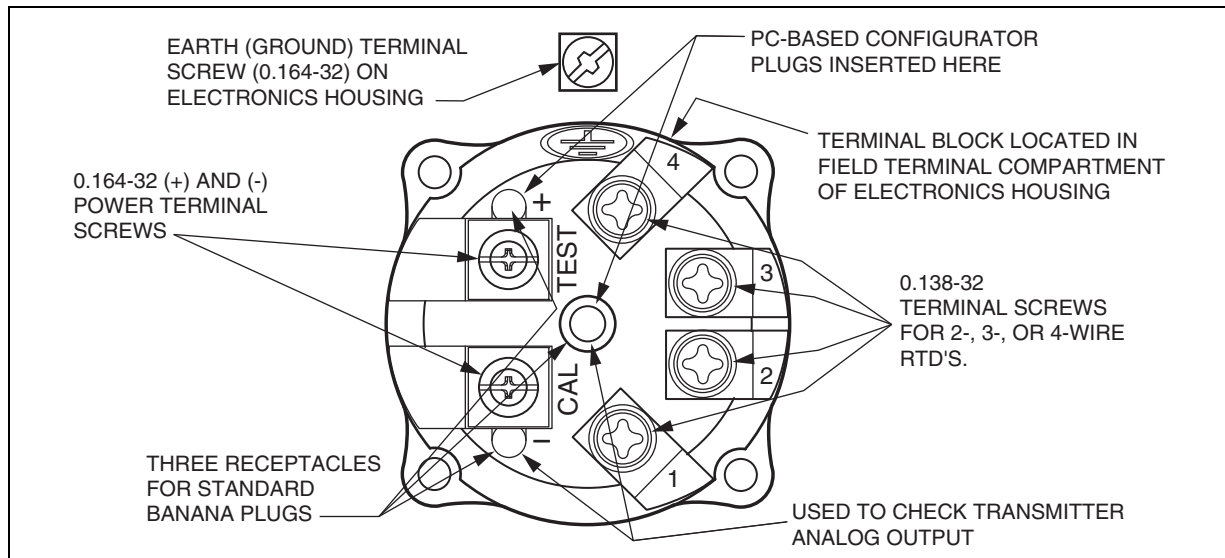

Figure 16. Field Terminal Connections

ELECTRICAL SAFETY SPECIFICATIONS

ELECTRICAL SAFETY SPECIFICATIONS

These transmitters have been designed to meet the electrical safety descriptions listed in the table that follows. For more detailed information, or status of testing laboratory approvals and certifications, contact Invensys. Refer to applicable Instruction Manual for application conditions and connectivity requirements.

Electronic Version -T (HART)

Testing Laboratory, Types of Protection, and Area Classification	Application Conditions	Electrical Safety Design Code
ATEX flameproof; II 2 GD, EEx d IIC, Zone 1.	Temperature Class T6, T85°C, Ta = -40°C to +80°C.	D
ATEX intrinsically safe; II 1 GD, EEx ia IIC, Zone 0, or II 1/2 GD, EEx ib IIC, Zone 0 and 1.	Temperature Class T4 at 80°C, T5 at 40°C, and T6 at 40°C maximum ambient.	E
ATEX protection n; II 3 GD, EEx nL IIC, Zone 2.	Temperature Class T4 at 80°C, T5 at 70°C, and T6 at 40°C maximum ambient.	N
ATEX multiple certifications, ia and ib, d, and n. Refer to ATEX Codes D, E, and N for details.	Applies to Codes D, E, and N.	M (a)
CSA intrinsically safe for Class I, Division 1, Groups A, B, C, and D, Class II, Division 1, Groups E, F, and G; Class III, Division 1. Also, zone certified intrinsically safe Ex ia IIC, and energy limited Ex nA II.	Temperature Class T4A at 40°C and T3C at 85°C maximum ambient. Temperature Class T4 at 40°C and T3 at 85°C maximum ambient.	C
CSA explosionproof for Class I, Division 1, Groups B, C, and D, and dust-ignitionproof for Class II, Division 1, Groups E, F, and G; and Class III, Division 1.	Maximum Ambient Temperature 85°C.	C
CSA Class I, Division 2, Groups A, B, C, and D; Class II, Division 2, Groups F and G; and Class III, Division 2.	Temperature Class T4A at 40°C and T3C at 85°C maximum ambient.	C
CSA field device zone certified flameproof Ex d IIC. Also, all certifications of Code C above.	Maximum Ambient Temperature 85°C.	B
FM intrinsically safe for Class I, Division 1, Groups A, B, C, and D, Class II, Division 1, Groups E, F, and G; Class III, Division 1. Also, zone certified intrinsically safe AEx ia IIC.	Temperature Class T4A at 85°C maximum ambient. Temperature Class T4 at 85°C maximum ambient.	F
FM explosionproof for Class I, Division 1, Groups B, C, and D; and dust-ignitionproof for Class II, Division 1, Groups E, F, and G; and Class III, Division 1.	Temperature Class T6 at 80°C and T5 at 85°C maximum ambient.	F
FM nonincendive for Class I, Division 2, Groups A, B, C, and D; Class II, Division 2, Groups F and G, and Class III, Division 2.	Temperature Class T4A at 85°C maximum ambient.	F
FM field device zone certified flameproof AEx d IIC. Also, all certifications of Code F above.	Temperature Class T6 at 80°C and T5 at 85°C maximum ambient.	G
IECEx flameproof; Ex d IIC.	T6, Ta = 80°C; T5, Ta = 85°C; Ambient Temperature -20°C to +85°C.	V

(a) When selecting ATEX Electrical Safety Design Code M, the user must permanently mark (check off in rectangle block on data plate) one type of protection only, ia and ib, d, or n. This mark cannot be changed once it is applied.

MODEL CODE

Description	Model																														
Multivariable Transmitter	IMV30																														
Electronics Versions and Output Signal																															
Intelligent; Digital HART and 4 to 20 mA dc (Version -T)	-T																														
Structure Code - Process Covers, Sensor Material, and Sensor Fill Fluid																															
With Traditional Structure																															
<table border="0"> <thead> <tr> <th>Covers</th> <th>Sensor</th> <th>Fill Fluid</th> <th></th> </tr> </thead> <tbody> <tr> <td>316 ss</td> <td>316L ss</td> <td>Silicone</td> <td>22</td> </tr> <tr> <td>316 ss</td> <td>316L ss</td> <td>Inert</td> <td>23</td> </tr> <tr> <td>316 ss</td> <td>Nickel alloy (a)</td> <td>Silicone</td> <td>26</td> </tr> <tr> <td>316 ss</td> <td>Nickel alloy (a)</td> <td>Inert</td> <td>27</td> </tr> <tr> <td>Nickel alloy (a)</td> <td>Nickel alloy (a)</td> <td>Silicone</td> <td>46</td> </tr> <tr> <td>Nickel alloy (a)</td> <td>Nickel alloy (a)</td> <td>Inert</td> <td>47</td> </tr> </tbody> </table>	Covers	Sensor	Fill Fluid		316 ss	316L ss	Silicone	22	316 ss	316L ss	Inert	23	316 ss	Nickel alloy (a)	Silicone	26	316 ss	Nickel alloy (a)	Inert	27	Nickel alloy (a)	Nickel alloy (a)	Silicone	46	Nickel alloy (a)	Nickel alloy (a)	Inert	47			
Covers	Sensor	Fill Fluid																													
316 ss	316L ss	Silicone	22																												
316 ss	316L ss	Inert	23																												
316 ss	Nickel alloy (a)	Silicone	26																												
316 ss	Nickel alloy (a)	Inert	27																												
Nickel alloy (a)	Nickel alloy (a)	Silicone	46																												
Nickel alloy (a)	Nickel alloy (a)	Inert	47																												
Span Limits - Differential Pressure (DP) Measurement																															
<table border="0"> <thead> <tr> <th>kPa</th> <th>inH₂O</th> <th>mbar</th> <th>Available with (b)</th> <th></th> </tr> </thead> <tbody> <tr> <td>0.12 and 2.5</td> <td>0.5 and 10</td> <td>1.2 and 25</td> <td>AP Code G only</td> <td>L</td> </tr> <tr> <td>0.75 and 7.5</td> <td>3 and 30</td> <td>7.5 and 75</td> <td>AP Code G only</td> <td>A</td> </tr> <tr> <td>0.5 and 50</td> <td>2 and 200</td> <td>5 and 500</td> <td>AP Codes D, E, H, and F only</td> <td>B</td> </tr> <tr> <td>2.5 and 210</td> <td>10 and 840</td> <td>25 and 2100</td> <td>AP Codes D, E, H, and F only</td> <td>C</td> </tr> </tbody> </table>	kPa	inH ₂ O	mbar	Available with (b)		0.12 and 2.5	0.5 and 10	1.2 and 25	AP Code G only	L	0.75 and 7.5	3 and 30	7.5 and 75	AP Code G only	A	0.5 and 50	2 and 200	5 and 500	AP Codes D, E, H, and F only	B	2.5 and 210	10 and 840	25 and 2100	AP Codes D, E, H, and F only	C						
kPa	inH ₂ O	mbar	Available with (b)																												
0.12 and 2.5	0.5 and 10	1.2 and 25	AP Code G only	L																											
0.75 and 7.5	3 and 30	7.5 and 75	AP Code G only	A																											
0.5 and 50	2 and 200	5 and 500	AP Codes D, E, H, and F only	B																											
2.5 and 210	10 and 840	25 and 2100	AP Codes D, E, H, and F only	C																											
Span Limits - Absolute Pressure (AP) Measurement (Absolute Measured; Gauge Calculated)																															
<table border="0"> <thead> <tr> <th>MPaa</th> <th>psia</th> <th>bara or kg/cm² abs</th> <th>Available with (b)</th> <th></th> </tr> </thead> <tbody> <tr> <td>0.02 and 2.1</td> <td>3 and 300</td> <td>0.21 and 21</td> <td>DP Codes B and C only</td> <td>D</td> </tr> <tr> <td>0.07 and 3.5</td> <td>10 and 500</td> <td>0.7 and 35</td> <td>DP Codes L and A only</td> <td>G</td> </tr> <tr> <td>0.21 and 10</td> <td>30 and 1500</td> <td>2.1 and 100</td> <td>DP Codes B and C only</td> <td>E</td> </tr> <tr> <td>0.42 and 20</td> <td>60 and 3000</td> <td>4.2 and 200</td> <td>DP Codes B and C only</td> <td>H</td> </tr> <tr> <td>3.4 and 36.5</td> <td>500 and 5300</td> <td>34 and 365</td> <td>DP Codes B and C only</td> <td>F</td> </tr> </tbody> </table>	MPaa	psia	bara or kg/cm ² abs	Available with (b)		0.02 and 2.1	3 and 300	0.21 and 21	DP Codes B and C only	D	0.07 and 3.5	10 and 500	0.7 and 35	DP Codes L and A only	G	0.21 and 10	30 and 1500	2.1 and 100	DP Codes B and C only	E	0.42 and 20	60 and 3000	4.2 and 200	DP Codes B and C only	H	3.4 and 36.5	500 and 5300	34 and 365	DP Codes B and C only	F	
MPaa	psia	bara or kg/cm ² abs	Available with (b)																												
0.02 and 2.1	3 and 300	0.21 and 21	DP Codes B and C only	D																											
0.07 and 3.5	10 and 500	0.7 and 35	DP Codes L and A only	G																											
0.21 and 10	30 and 1500	2.1 and 100	DP Codes B and C only	E																											
0.42 and 20	60 and 3000	4.2 and 200	DP Codes B and C only	H																											
3.4 and 36.5	500 and 5300	34 and 365	DP Codes B and C only	F																											
Process Connector Type (Material Same as Process Cover Material)																															
None, Covers tapped for 1/4 NPT	0																														
1/4 NPT (Not Available with Structure Codes 46 and 47 - Nickel alloy (a) Process Covers)	1																														
1/2 NPT	2																														
Rc 1/4 (Not Available with Structure Codes 46 and 47) - Nickel alloy (a) Process Covers	3																														
Rc 1/2	4																														
1/2 Schedule 80 Welding Neck (Not Available with Structure Codes 46 and 47 - Nickel alloy (a) Process Covers)	6																														
Conduit Connection and Housing Material																															
1/2 NPT Connection, Aluminum Housing	1																														
PG 13.5 Connection, Aluminum Housing (Available with Electrical Safety Codes E, D, M, and N only)	2																														
1/2 NPT Connection, 316 ss Housing	3																														
PG 13.5 Connection, 316 ss Housing (Available with Electrical Safety Codes E, D, M, and N only)	4																														
M20 Connection, Aluminum Housing (Available with Electrical Safety Codes E, D, M, and N only)	5																														
M20 Connection, 316 ss Housing (Available with Electrical Safety Codes E, D, M, and N only)	6																														

MODEL CODE

MODEL CODE (CONTINUED)

Description	Model
Electrical Safety (Also see Electrical Safety Specifications section)	
ATEX Certifications:	
ATEX II 1 GD, EEx ia IIC, Zone 0; or II 1/2 GD, EEx ib IIC, Zone 0/Zone 1	E
ATEX II 2 GD, EEx d IIC, Zone 1 (c)	D
ATEX II 3 GD, EEx nL IIC, Zone 2	N
ATEX Multiple Certifications (includes ATEX Codes E, D, and N) (c)	M
(See Electrical Safety Specifications section for <u>user marking</u>)	
CSA Certifications:	C
Division 1 explosionproof and dust-ignitionproof	
Division 1 intrinsically safe, also zone certified Ex ia IIC, and Ex nL II	
Division 2, Classes I, II, and III	
CSA Certifications: (c)	B
Zone certified flameproof, Ex d IIC. Also all certifications of Code C above	
FM Approvals:	F
Division 1 explosionproof and dust-ignitionproof	
Division 1 intrinsically safe, also zone approved AEx ia IIC	
Division 2, Classes I, II, and III; nonincendive	
FM Approvals: (c)	G
Zone approved flameproof, AEx d IIC. Also all certifications of Code F above	
IECEx flameproof, Ex d IIC	V
Optional Selections (See PSS 2A-1Z9 E for Options/Accessories not listed in Model Code)	
Refer to descriptions that follow.	
Mounting Bracket Set	
Painted Steel Bracket with Plated Steel Bolts	-M1
Stainless Steel Bracket with Stainless Steel Bolts	-M2
Digital Indicator with Pushbuttons	
Digital Indicator, Pushbuttons, and Window Cover	-L1
DIN 19213 Construction used with Process Connector Code 0 and 316 ss Process Covers Only	
Process	
Cover Screw	
Connector Screw	
Cover Type	
Material	
Size	
Material	
Single Ended	-
Double Ended (d)	Steel
(Blind Kidney Flange on back)	
Single Ended	-
Double Ended (d)	Steel
(Blind Kidney Flange on back)	
Single Ended	-
Double Ended (d)	316 ss
(Blind Kidney Flange on back)	
Single Ended	-
Double Ended (d)	17-4 ss
(Blind Kidney Flange on back)	
Single Ended	-
Double Ended (d)	17-4 ss
(Blind Kidney Flange on back)	

MODEL CODE (CONTINUED)

Description	Model
Cleaning and Preparation	
Unit Degreased - for Silicone Filled Sensors Only (Not for Oxygen/Chlorine/Other Fluids that may react with Silicone)	-X1
Cleaned and Prepared for Oxygen Service - for Inert Filled Sensors Only	-X2
Cleaned and Prepared for Chlorine Service - for Inert Filled Sensors Only (includes 17-4 ss bolting; therefore do not also specify Option -B2)	-X3
Bolting for Process Covers/Connectors - Not Available with DIN 19213 Construction	
316 ss Bolts and Nuts (e)	-B1
17-4 ss Bolts and Nuts (e)	-B2
B7M Bolts and Nuts (e) (f)	-B3
Conduit Connectors	
Hawke-Type 1/2 NPT Cable Gland for use with Conduit Connection Codes 1 and 3 Not available with Electrical Safety Code F	-A1
M20 Conduit Thread Adapter for use with Conduit Connection Codes 1 and 3 Only available with Electrical Safety Code D	-A3
Electronics Housing Features	
Custody Transfer Lock and Seal	-Z2
Tubing Connectors	
316 ss, Connecting 6 mm Tubing to 1/4 NPT Process Connector (g)	-E3
316 ss, Connecting 12 mm Tubing to 1/2 NPT Process Connector (h)	-E4
Custom Factory Configuration	
Full Factory Configuration (Requires completion of Multivariable Configuration Wizard before entering the order) (i)	-C2
Vent Screw in Process Cover	
Supply Vent Screw in Side of Each Process Cover (Not available with DIN 19213 Construction Options -D1 to -D8.)	-V
Instruction Books (Common MI, Brochure, and Full Documentation Set on CD-ROM is Standard)	
Without Instruction Book and CD; only "Getting Started" brochure is supplied	-K1
Miscellaneous Optional Selections	
Low Temperature Operative Limits of Electronics Housing Extended down to -50°C (-58°F) (j) (k)	-J
Supplemental Customer Tag (Stainless Steel Tag wired onto Transmitter)	-T
Example: IMV30-T22BD21F-M1L1V	

- (a) Equivalent to Hastelloy® C.
- (b) See Span and Range Limits tables in Functional Specifications section for allowable DP and AP Span Limit Code combinations.
- (c) A cover lock is provided as standard construction with Electrical Safety Codes D, B, G, and M.
- (d) Temperature limits are 0 and 60°C (32 and 140°F) with Options -D2, -D4, -D6, and -D8. Also not available with Mounting Bracket Sets -M1 and -M2.
- (e) Not available with DIN 19213 Construction Options -D1 to -D8. Select Option Codes -D5 to -D8 to get stainless bolting on DIN 19213 Transmitters.
- (f) Selection of Option -B3 normally requires selection of Auxiliary Specification (AS) MR-01 (NACE Standard MR 01-75).
- (g) Only available with Structure Codes 22 and 23; and only with Process Connector Codes 0 and 1.
- (h) Only available with Structure Codes 22 and 23; and only with Process Connector Code 2.

- (i) Invensys recommends the selection of Option -C2 if the application information is known. If Option -C2 is not selected, a standard default configuration will be provided. The user will then need the Model PCMV to completely configure the transmitter for flow rate applications.
- (j) Option -J not available with:
 - Structures with Inert Fill (Codes 23, 27,47, LM, and LD)
 - DIN Construction Options -D2, -D4, -D6, and -D8.
- (k) -50°C indicates sensor and electronics ambient temperature capabilities. Performance is not assured below -29°C. Sensor damage may occur if process is frozen.

SUGGESTED RFQ SPECIFICATIONS

The manufacturer shall provide field-mounted multivariable transmitter(s) featuring remote digital communications capability for measuring absolute pressure, differential pressure, and temperature, and transmitting a 4 to 20 mA dc and/or digital output signal (software selectable) for use in a standard two-wire dc supply voltage system. The transmitted signals shall be used with a PC-based configurator for transmission of calculated mass flow rate measurements. The specifications for this Multivariable transmitter are as follows:

Communication Protocol:	HART, digital and/or 4 to 20 mA dc output signal
Remote Communications:	Must not interfere with output
Accuracy:	Digital Output: $\pm 0.05\%$ of calibrated span 4 to 20 mA Output: $\pm 0.075\%$ of calibrated span
Damping:	Settable for a range of none to 32 seconds
RFI Protection:	0.1% error between 27 and 1000 MHz at 30 V/m field intensity
Span Limits:	Absolute Pressure Measurement 3 and 300, 10 and 500, 30 and 1500, 60 and 3000, and 500 and 5300 psi, or SI/Metric Equivalents Differential Pressure Measurement 0.5 and 10 inH ₂ O, 3 and 30 inH ₂ O, 2 and 200 inH ₂ O, 10 and 840 inH ₂ O, or SI/Metric Equivalents
Process Temperature:	Transmitter includes terminals to receive either a 2-, 3-, or 4-wire, 100 ohm, platinum DIN/IEC RTD to measure process temperature. Span Limits are 10 and 538°C (50 and 1000°F); and Range Limits are -200 and +850°C (-328 and 1562°F).
Mounting:	On process piping or optional mounting bracket
Input Connection:	With process connectors to accept 1/4 NPT, 1/2 NPT, Rc 1/4 or Rc 1/2, 1/2 Schedule 80 welding neck
Electronics Housing:	Aluminum housing with epoxy finish, or 316 ss housing; with 1/2 NPT, PG 13.5, or M20 conduit connections.
Modular Electronics:	Easily replaceable modular electronics in a NEMA 4X (IEC IP66) housing sealed with O-rings for protection against moisture or other contaminants. Optional integral LCD Indicator with on-board configuration pushbuttons.
Process Cover Materials Available:	316 ss or nickel alloy (equivalent to Hastelloy® C)
Sensor Materials Available:	316L ss or nickel alloy (equivalent to Hastelloy® C)
Approvals and Certifications:	Must be suitable for Division 1 and Zone 0, Zone 1 hazardous area locations, and conform to all applicable European Union Directives. Versions available to meet agency flameproof and zone requirements.
Approximate Mass:	3.5 kg (7.8 lb), without process connectors; 4.2 kg (9.2 lb), with process connectors; With 316 ss housing, add 1.1 kg (2.4 lb); With optional LCD indicator, add 0.2 kg (0.4 lb).
Model Code:	I/A Series Intelligent IMV30 Multivariable Transmitter with HART Communication Protocol, or equivalent

DIMENSIONS - NOMINAL
 $\frac{\text{mm}}{\text{in}}$
TRANSMITTER WITH TRADITIONAL STRUCTURE

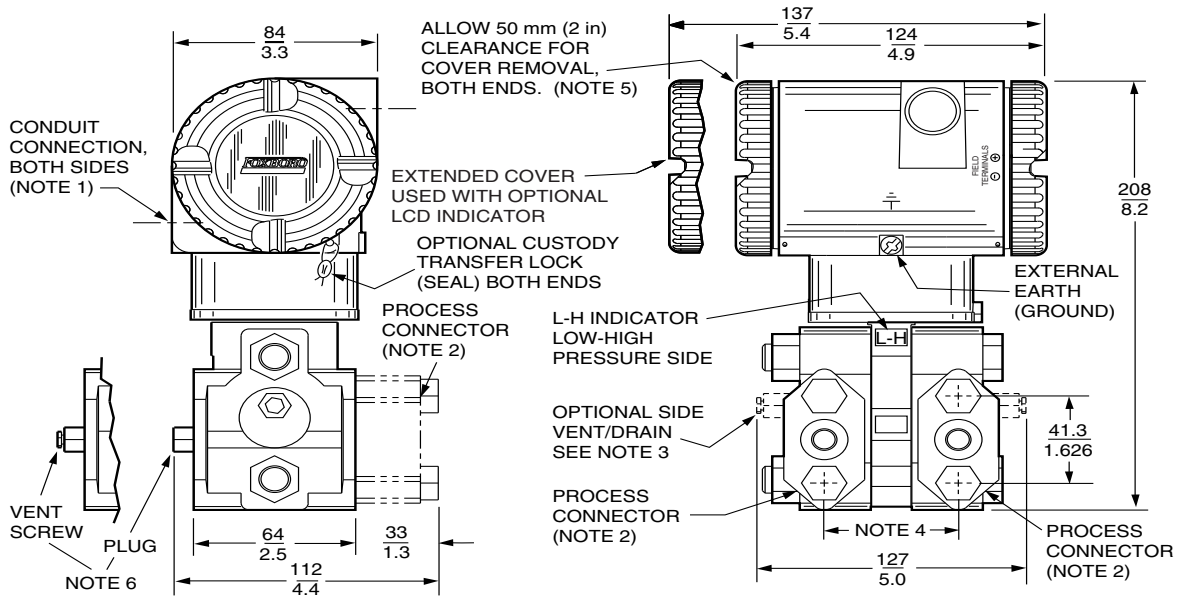

NOTES:

1. CONDUIT CONNECTION 1/2 NPT, PG 13.5, OR M20, BOTH SIDES: PLUG UNUSED CONNECTION WITH METAL PLUG (SUPPLIED).
2. PROCESS CONNECTORS MAY BE REMOVED AND TRANSMITTER MOUNTED DIRECTLY ON A MANIFOLD, OR CONNECTIONS MADE DIRECTLY TO PROCESS COVER USING 1/4 NPT INTERNAL THREAD IN PROCESS COVER.
3. PROCESS COVER CAN BE INVERTED MAKING OPTIONAL SIDE VENTS OR SIDE DRAINS
4. PROCESS CONNECTORS CAN BE INVERTED TO GIVE EITHER 51, 54, OR 57 mm (2.0, 2.125, OR 2.25 in) CENTER-TO-CENTER DISTANCE BETWEEN HIGH AND LOW PRESSURE CONNECTIONS.
5. TOPWORKS CAN BE ROTATED TO ANY POSITION WITHIN ONE TURN COUNTERCLOCKWISE OF THE FULLY TIGHTENED POSITION.
6. PROCESS COVER END PLUGS ARE SUBSTITUTED FOR VENT SCREWS WHEN OPTIONAL SIDE VENTS (NOTE 3) ARE SPECIFIED.

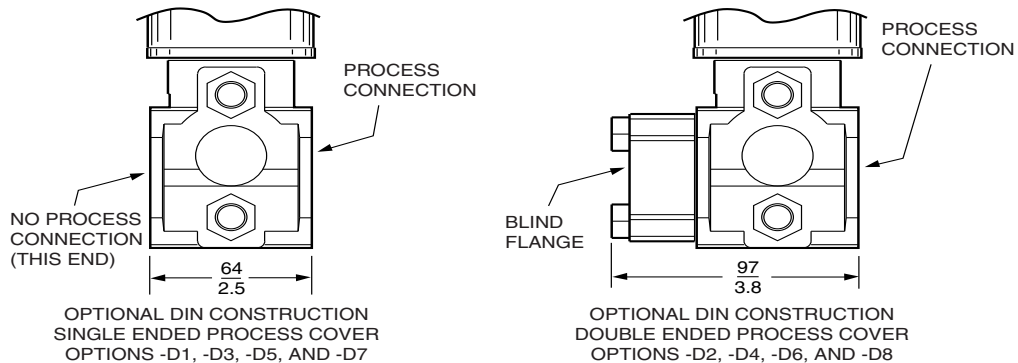

NOTE: Refer to Dimensional Print DP 020-432 for further information.

ORDERING INSTRUCTIONS

1. Model Number.
2. Calibrated Pressure Ranges for both DP and AP using allowable pressure units from the table below.

inH ₂ O	inHg	Pa	torr	g/cm ²	psia
ftH ₂ O	mmHg	kPa	mbar	kg/cm ²	atm
mmH ₂ O		MPa	bar		

3. Configuration Data Form when Factory Configuration Option -C2 is specified.
4. Optional Features and Accessories not Included in Model Code (See PSS 2A-1Z9 E).
5. User Tag Data - Data Plate, 32 characters maximum.
For additional Tag Data, specify Optional Supplemental Customer Tag -T.
6. User Tag Data - Software (Database): Version -T, HART; 8 characters maximum.

OTHER M&I PRODUCTS

Invensys provides a broad range of measurement and instrument products, including solutions for pressure, flow, analytical, positioners, temperature, controlling and recording. For a listing of these offerings, visit the Invensys Operations Management web site at:

www.iom.invensys.com