

Rotary actuators for ball valves

GMA..9E..



Electromotive rotary actuators with spring return for fail-safe function on 2-position, 3-position, and modulating control. Used on heating, ventilation, and air conditioning plants

- For 2-port and 3-port control ball valves, internally threaded connections (VAI61.. and VBI61..) or externally threaded connections (VAG61.. and VBG61..), DN15 to DN50.
- For open/close ball valves 2-port and changeover ball valves 3-port, internally threaded connections (VAI60.. and VBI60..) or externally threaded connections (VAG60.. and VBG60..), DN15 to DN50.
- Nominal torque 7 Nm
- GMA1..1.9E: Operating voltage AC 24 V / DC 24...48 V
- GMA161.9E/MO: Operating voltage AC 24 V / DC 24 V
- GMA321.9E: Operating voltage AC 230 V ~
- Positioning signal DC 0/2...10 V=
- GMA161.9E/MO: RS-485 for Modbus RTU communication
- Prewired with 0.9 m connecting cable

Features

- Brushless, robust DC motors ensure reliable operation regardless of load.
- The valve actuators do not require an end position switch, are overload proof, and remain in place upon reaching the end stop.
- The gears are maintenance free and low noise.
- Suitable for use with modulating (DC 0...10 V), 2-position or 3-position controllers.
- We recommend a minimum pulse length of 500 ms on rotary actuators operated with 3-point control to ensure continuous and accurate operation.
- On plants where the rotary actuator must move to the zero position (emergency position) during power failure.

Functions

| Type ¹⁾ | GMA..21.9E | GMA131.9E | GMA161.9E | GMA161.9E/MO |
|--|---|--|--|---|
| Control type | 2-position | 3-position | Modulating | Modbus RTU |
| Rotary direction as per mounting on ball valve | NC (normally closed) ball valve | NC (normally closed) ball valve | NC (normally closed) ball valve | |
| | Switch on operating voltage: <ul style="list-style-type: none"> • Actuator opens Switch off operating voltage: <ul style="list-style-type: none"> • Actuator closes with spring return (clockwise) | Signal to Y1 <ul style="list-style-type: none"> • – rotation counter-clockwise • – ball valve opens Signal to Y2 <ul style="list-style-type: none"> • – rotation clockwise • – ball valve closes | 0...10 V "counter-clockwise" Flow = 0% at Y = 0 V Flow = 100% at Y = 0 V | 0...100% "counter-clockwise" Flow = 0% at Reg. 1 = 0 Flow = 100% at Reg. 1 = 10.000 |
| See mounting instructions M4658 for other switchings. | | | | |
| Emergency position (Spring return) | On power failure or when the operating voltage is switched off, the spring moves the rotary actuator to its mechanical zero position. | | | |
| Position indication: Mechanical | Rotary angle position indication as position indicator. ²⁾ | | | |
| Position indication: Electrical | | | Output voltage U = DC 0 to 10 V is generated proportional to rotary angle.. | |
| Manual adjustment | <ul style="list-style-type: none"> • Without voltage supplied, the rotary actuator can be rotated and fixed in any position using the supplied Allen wrench. • The rotary actuator returns to the zero position (actuator closed) if mechanically unlocked with an Allen wrench or via short-term voltage | | | |
| Modbus RTU (RS-485), not galvanically isolated | | | | Setpoint 0...100 % valve setting Actual value 0...100 % for valve position forced control open / close / Min / Max / Stop Setpoint monitoring and backup mode |

1) When combining GMA..1E and ASK77.2: Carefully read mounting instructions M4696 (74 319 0648 0)!

2) Manual adjustment of the position indicator can cause damage to the unit.

Technical design

Housing

The housing is made of aluminum:

- Flame retardant

Type summary

| Type | Item NO. | Positioning signal | Operating voltage | Position indicator U = DC 0...10 V | Self-adaption Rotational angle area | Auxiliary switch | Rotation direction switch |
|--------------|---------------|--------------------|----------------------------|------------------------------------|-------------------------------------|------------------|---------------------------|
| GMA121.9E | BPZ:GMA121.9E | 2-position | AC 24 V ~ / DC 24...48 V = | – | – | – | Yes |
| GMA321.9E | BPZ:GMA321.9E | | AC 230 V ~ | – | – | – | |
| GMA131.9E | BPZ:GMA131.9E | 3-position | AC 24 V ~ / DC 24...48 V = | – | – | – | |
| GMA161.9E | BPZ:GMA161.9E | DC 0...10 V = | AC 24 V ~ / DC 24...48 V = | Yes | Yes | – | |
| GMA161.9E/MO | S55499-D683 | Modbus RTU | AC 24 V ~ / DC 24 V = | Yes | Yes | – | |

Accessories / spare parts

Accessories

| ⚠ DANGER | |
|--|---|
|  | <p>Hazard to life caused by a lack of ground for the combination ALJ100 with GMA321.9E!</p> <p>Combining rotary actuator GMA321.9E operated at AC 230 V ~ with temperature adapter ALJ100 results in life-threatening shocks due to a lack of ground.</p> <ul style="list-style-type: none"> Never combine rotary actuator GMA321.9E with temperature adapter ALJ100. |

| Type | Stock number | Description |
|--------|--------------|-------------------------------------|
| ALJ100 | S55846-Z115 | Temperature adapter for ball valves |

Equipment combinations

Rotary actuators are suitable for operating following Siemens ball valves:

VA..61.. 2-port control ball valves

| Control ball valves with: | | | | k _{vs} [m ³ /h] | DN | GMA..9E.. | | |
|--------------------------------|--------|--------------------------------|---------|-------------------------------------|----|-------------------|-----------------|------|
| Internal threads ¹⁾ | Rp | External threads ²⁾ | G..B | | | Δp _{max} | Δp _s | |
| – | – | VAG61.15.. | G 1 B | 1...6.3 | 15 | 350 | 1400 | |
| VAI61.15.. | Rp ½" | – | – | 0.25...10 | 15 | | | |
| VAI61.20.. | Rp ¾" | VAG61.20.. | G 1 ¼ B | 4...10 | 20 | | | |
| VAI61.25.. | Rp 1" | VAG61.25.. | G 1 ½ B | 6.3...16 | 25 | | | |
| VAI61.32.. | Rp 1¼" | VAG61.32.. | G 2 B | 10...25 | 32 | | | 1000 |
| VAI61.40.. | Rp 1½" | VAG61.40.. | G 2 ¼ B | 16...40 | 40 | | | 800 |
| VAI61.50.. | Rp 2" | VAG61.50.. | G 2 ¾ B | 25...63 | 50 | 600 | | |

VB..61..
3-Port control ball valves

| Control ball valves with: | | | | k _{vs} [m ³ /h] | DN | GMA..9E.. | |
|--------------------------------|--------|--------------------------------|---------|-------------------------------------|----|-------------------|-----------------|
| Internal threads ¹⁾ | Rp | External threads ²⁾ | G..B | | | Δp _{max} | Δp _s |
| VBI61.15.. | Rp ½" | VBG61.15.. | G 1 B | 1.6...6.3 | 15 | 350 | – |
| VBI61.20.. | Rp ¾" | VBG61.20.. | G 1 ¼ B | 4...6.3 | 20 | | |
| VBG61.25-10 | Rp 1" | VBG61.25-10 | G 1 ½ B | 10 | 25 | | |
| VBI61.32-16 | Rp 1¼" | VBG61.32-16 | G 2 B | 16 | 32 | | |
| VBI61.40-25 | Rp 1½" | VBG61.40-25 | G 2 ¼ B | 25 | 40 | | |
| – | – | VBG61.50-40 | G 2 ¾ B | 40 | 50 | | |
| VBI61.50.. | Rp 2" | – | – | 40...63 | 50 | | |

¹⁾ Data sheet N4211

²⁾ Data sheet N4212

VA..60.. / VB..60..
2-port shut-off valves and 3-port changeover ball valves

| Control ball valves with: | | | | k _{vs} [m ³ /h] | DN | GMA..9E.. | | |
|--------------------------------|--------|--------------------------------|---------|-------------------------------------|----|-------------------|-----------------|------|
| Internal threads ³⁾ | Rp | External threads ⁴⁾ | G..B | | | Δp _{max} | Δp _s | |
| – | – | VAG60.15-9 | G 1 B | 9 | 15 | 350 | 1400 | |
| VAI60.15-15 | Rp ½" | – | – | 15 | 15 | | | |
| – | – | VAG60.20-17 | G 1 ¼ B | 17 | 20 | | | |
| VAI60.20-22 | Rp 1" | – | – | 22 | 20 | | | |
| VAI60.25-22 | Rp 1" | VAG60.25-22 | G 1 ½ B | 22 | 25 | | | |
| VAI60.32-35 | Rp 1¼" | VAG60.32-35 | G 2 B | 35 | 32 | | | 1000 |
| VAI60.40-68 | Rp 1½" | VAG60.40-68 | G 2 ¼ B | 68 | 40 | | | 800 |
| VAI60.50-96 | Rp 2" | VAG60.50-96 | G 2 ¾ B | 96 | 50 | 600 | | |

| | | | | | | | |
|--------------|--------|--------------|---------|----|----|-----|---|
| VBI60.15-5L | Rp ½" | VBG60.15-5L | G 1 B | 5 | 15 | 350 | – |
| – | – | VBG60.20-8L | G 1 ¼ B | 8 | 20 | | |
| VBI60.20-9L | Rp 1" | – | – | 9 | 20 | | |
| VBI60.25-9L | Rp 1" | VBG60.25-9L | G 1 ½ B | 9 | 25 | | |
| VBI60.32-13L | Rp 1¼" | VBG60.32-13L | G 2 B | 13 | 32 | | |
| VBI60.40-25L | Rp 1½" | VBG60.40-25L | G 2 ¼ B | 25 | 40 | | |
| VBI60.50-37L | Rp 2" | VBG60.50-37L | G 2 ¾ B | 37 | 50 | | |

| | | | | | | | |
|--------------|-------|--------------|---------|----|----|-----|---|
| – | – | VBG60.15-8T | G 1 B | 8 | 15 | 350 | – |
| VBI60.15-12T | Rp ½" | – | – | 12 | 15 | | |
| – | – | VBG60.20-13T | G 1 ¼ B | 13 | 20 | | |

| | | | | | | | |
|--------------|--------|--------------|---------|----|----|--|--|
| VBI60.20-16T | Rp 1" | – | – | 16 | 20 | | |
| – | – | VBG60.25-13T | G 1 ½ B | 13 | 25 | | |
| VBI60.25-16T | Rp 1" | – | – | 16 | 25 | | |
| VBI60.32-25T | Rp 1¼" | VBG60.32-25T | G 2 B | 25 | 32 | | |
| VBI60.40-49T | Rp 1½" | VBG60.40-49T | G 2 ¼ B | 49 | 40 | | |
| VBI60.50-73T | Rp 2" | VBG60.50-73T | G 2 ¾ B | 73 | 50 | | |

³⁾ Data sheet N4213

⁴⁾ Data sheet N4214

Product documentation

| Topic | Title | Document ID |
|-----------------------|----------------------------------|-------------|
| Data sheet | Rotary actuators for ball valves | N4658 |
| Mounting instructions | GMA..9E.. | M4658 |
| Mounting instructions | VAI61 / VBI61.. | M4211 |
| Mounting instructions | VAG61 / VBG61.. | M4212 |
| Mounting instructions | VAI60.. / VBI60.. | M4213 |
| Mounting instructions | VAG60.. / VBG60.. | M4214 |



Related documents such as the environmental declarations, CE declarations, etc., can be downloaded from the following Internet address:

<https://siemens.com/bt/download>

Notes

Additional information on rotary actuators is available in document Z4614.

Safety

|  CAUTION | |
|--|--|
|  | <p>National safety regulations</p> <p>Failure to comply with national safety regulations may result in personal injury and property damage.</p> <ul style="list-style-type: none"> ● Observe national provisions and comply with the appropriate safety regulations. ● Mounting, commissioning, and service by properly trained personnel only. |

Engineering

We recommend using temperature adapter ALJ100 in locations exposed to condensation to protect the actuator. Lubricate the adapter axle with silicon grease at medium temperatures $\leq 0\text{ }^{\circ}\text{C}$.

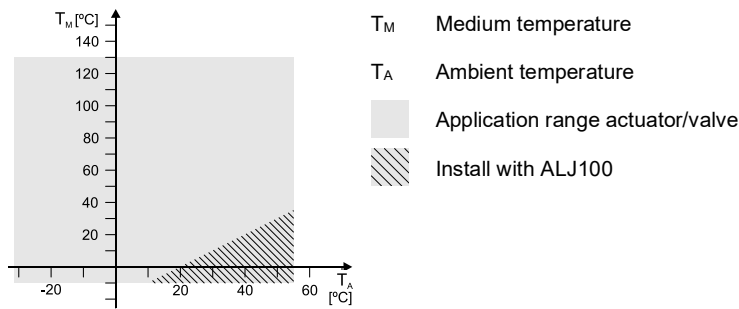

GMA161.9E/MO

The Modbus converter is designed for analog control at 0...10 V.

Mounting

Both ball valve and rotary actuator can be easily and directly assembled at the mounting location. No special tools or adjustments required.

Alignment

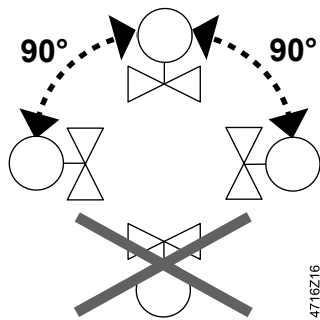

Installation

⚠ WARNING



No internal line protection for supply lines to external consumers

Risk of fire and injury due to short-circuits!

- Adapt the wire cross sections as per local regulations to the rated value of the installed fuse.

Commissioning

When commissioning the system, check both wiring and rotary actuator functions.

Maintenance

GMA..9E.. actuators are maintenance-free.

⚠WARNING



Tensioned return spring

Opening the drive housing can release the highly tensioned return spring, possibly resulting in injury due to flying parts.

- Do not open the drive housing.

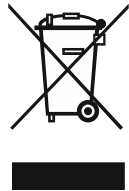

The device is considered an electronic device for disposal in accordance with European guidelines and may not be disposed of as domestic waste.

- Dispose of the device through channels provided for this purpose.
- Comply with all local and currently applicable laws and regulations.

Warranty service

The application-specific technical data is guaranteed only in combination with the Siemens products listed in the 'Device combinations' section. If third-party products are used, any guarantee provided by Siemens will be invalidated.

| Power GMA1..9E.. | | | |
|-------------------------|-----------|-----------------------|----------------|
| Operating voltage AC | | AC 24 V ± 20 % | |
| Frequency | | 50/60 Hz | |
| Operating voltage DC | | DC 24...48 V ± 20 % | |
| Power consumption | Operation | AC: 5 VA / 3.5 W | |
| | | DC: 3.5 W | |
| | Hold | GMA121.9E / GMA131.9E | AC / DC: 2 W |
| | | GMA161.9E.. | AC / DC: 2,5 W |

| Power GMA321.9E | | |
|------------------------|-----------|-----------------|
| Operating voltage | | AC 230 V ± 10 % |
| Frequency | | 50/60 Hz |
| Power consumption | Operation | 7 VA / 4.5 W |
| | Hold | 3.5 W |

| Function data | | |
|--|---|----------|
| Nominal torque | | 7 Nm |
| | Maximum torque (when blocked) | 21 Nm |
| | Minimum holding torque | 4 Nm |
| Nominal rotation angle (with position indication) | | 90° |
| | Maximum rotation angle (mechanically limited) | 95° ± 2° |
| Runtime at nominal rotational angle 90° | | 90 [s] |
| Closing time with spring return (on power failure) | | 15 s |

| Inputs GMA1..9E.. | | | |
|--------------------------|--|-------------|----------------|
| Positioning signal | | | |
| | Switching current (at AC 24 V / DC 24...48 V =) for "Open"/"Close" | | > AC / DC 8 mA |
| | Input voltage Y | (wires 8-2) | DC 0...10 V = |
| | Max. permissible input voltage | | DC 35 V |
| | | (Wires 9-2) | DC 0...10 V = |
| | Max. output current | | DC ± 1 mA |

| Communication GMA161.9E/MO | | |
|----------------------------|----------------------|--|
| Communication protocol | | |
| | Modbus RTU | RS-485, not galvanically isolated |
| | Number of nodes | Max. 32 |
| | Address range | 1...248 / 255 |
| | Factory setting | 255 |
| | Transmission formats | 1-8-E-1 / 1-8-O-1 / 1-8-N-1 / 1-8-N-2 |
| | Factory setting | 1-8-E-1 |
| | Baud rates (kbaud) | Auto / 9.6 / 19.2 / 38.4 / 57.6 / 76.8 / 115.2 |
| | Factory setting | Auto |
| | Bus termination | 120 Ω electronically switchable |
| | Factory setting | Off |

| Outputs GMA1..9E.. | | |
|--------------------|---------------------|---------------------------|
| Output signal | | |
| | Output voltage U | (Wires 9-2) DC 0...10 V = |
| | Max. output current | DC ± 1 mA |

| Connection cables | |
|---------------------|----------------------|
| Cable length | 0.9 m |
| Cable cross-section | 0.75 mm ² |

| Ambient conditions and protection classification | | |
|--|---------------------------|-----------------------------|
| Device IP class per EN 60730 | | |
| | AC 24 V ~ / DC 24 V = | III |
| | AC 230 V ~ | II |
| Degree of protection of housing to EN 60529 | | IP54 |
| Operation | | As per IEC 60721-3-3 |
| | Climatic conditions | Class 2K3 |
| | Temperature (extended) | -32...55 °C |
| | Humidity (non-condensing) | <95 % r.h. |
| Transportation | | Transport per IEC 60721-3-2 |
| | Climatic conditions | Class 3K5 / Class 2K3 |
| | Temperature (extended) | -32...70 °C |
| | Humidity (non-condensing) | <95 % r.h. |
| Storage | | Per IEC 60721-3-1 |
| | Climatic conditions | Class 1K3 |

| Ambient conditions and protection classification | |
|--|-------------|
| Temperature (extended) | -32...50 °C |
| Humidity (non-condensing) | <95 % r.h. |
| Mechanical ambient conditions | Class 2M2 |

| Standards, directives and approvals | |
|--|---|
| Product standards | EN 60730 Part 2-14: Particular requirements for electric actuators |
| Electromagnetic compatibility (field of use) | For residential, commercial, and industrial environments |
| EU conformity (CE) | 8000081792 ¹⁾ |
| RCM conformity | 8000081793 ¹⁾ |

| Environmental compatibility |
|---|
| The product environmental declaration CE1E4614en ¹⁾ contains data on environmentally compatible product design and assessments (RoHS compliance, materials composition, packaging, environmental benefit, disposal). |

| Dimensions |
|--|
| See Dimensions [▶ 13] |

| Weight GMA1..9E.. | |
|---------------------------|---------|
| Excl. packaging | 1.2 kg |
| External Modbus converter | 0.15 kg |

| Weight GMA321.9E | |
|------------------|--------|
| Excl. packaging | 1.3 kg |

¹⁾ Documents can be downloaded at <http://www.siemens.com/bt/download>

Internal diagrams

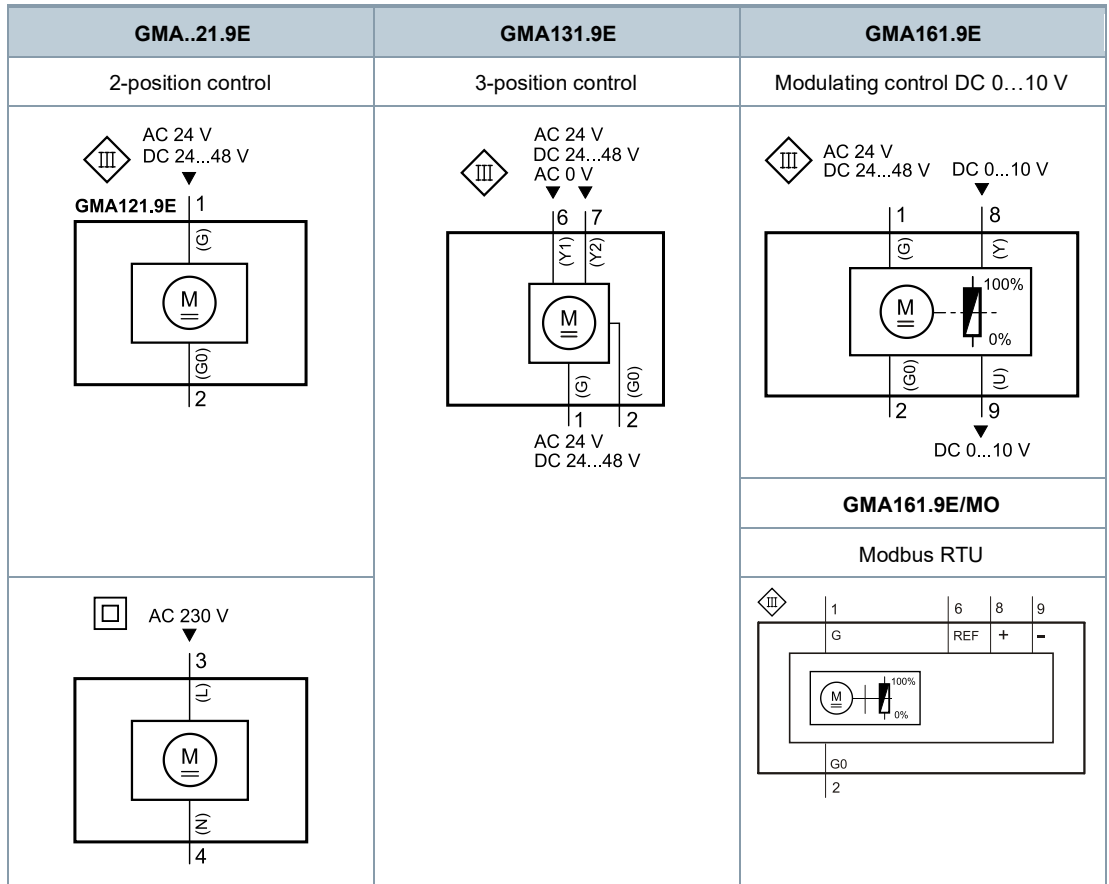

Connection diagrams

Single pole single throw (SPST)

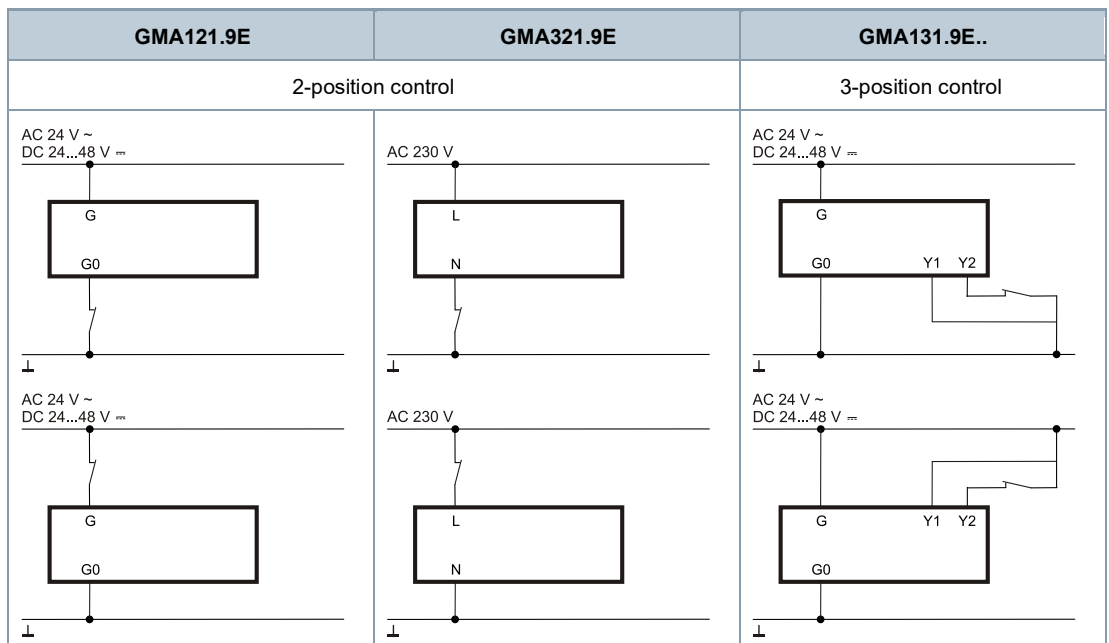

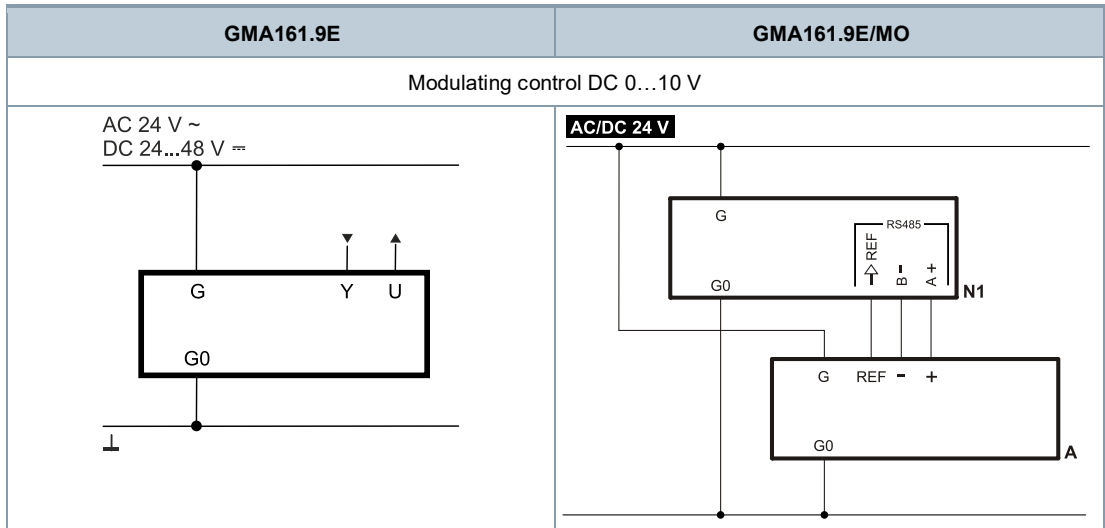

Cable designations

| Connecting thread | Cable | | | | Meaning |
|--|-------|-----|--------|--------------|---|
| | Code | No. | Color | Abbreviation | |
| Rotary actuators AC 24 V ~ DC 24 V = | G | 1 | Red | RD | System potential AC 24 V ~ / DC 24 V...48 V = |
| | G0 | 2 | Black | BK | System neutral |
| | Y1 | 6 | Purple | VT | Positioning signal AC 0 V, AC 24 V ~ / DC 24...48 V = "Counter-clockwise" NC. |
| | Y2 | 7 | Orange | OG | Positioning signal AC 0 V, AC 24 V ~ / DC 24...48 V = "Clockwise" NC. |
| | Y | 8 | Gray | GY | Positioning signal DC 0...10 V |
| Rotary actuators AC 230 V ~ | U | 9 | Pink | PK | Position indication 0...10 VDC |
| | L | 3 | Brown | BN | Phase AC 230 V |
| Modbus AC 24 V ~ DC 24 V = | N | 4 | Blue | BU | Neutral conductor |
| | REF | 6 | Purple | VT | Reference line (Modbus RTU) |
| | + | 8 | Gray | GY | Bus + (Modbus RTU) |
| | - | 9 | Pink | PK | Bus - (Modbus RTU) |

Actuator

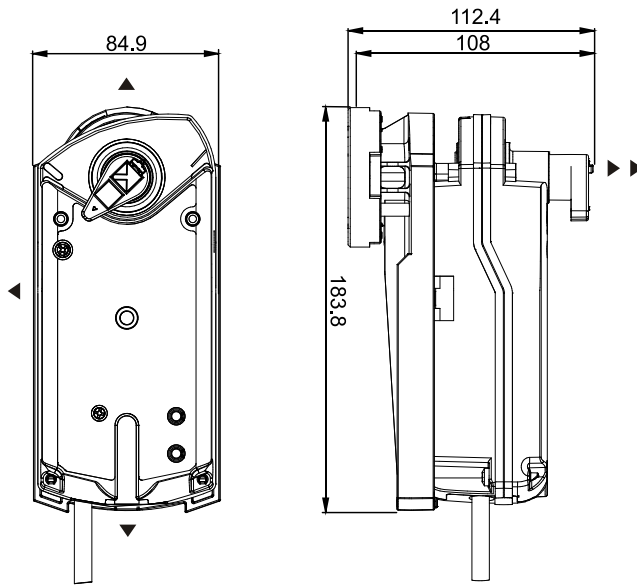

Dimensions in mm

- ▶ => 100 mm
- ▶ => 200 mm
- ▶

Min. clearance from ceiling or wall for mounting, connection, operation, maintenance, etc.

External Modbus converter

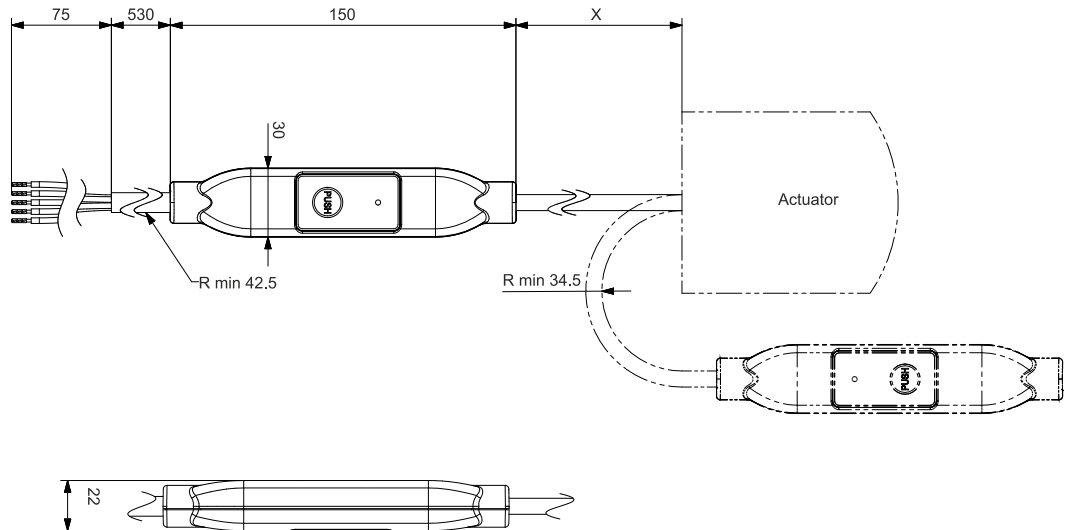

Temperature adapter (optional)

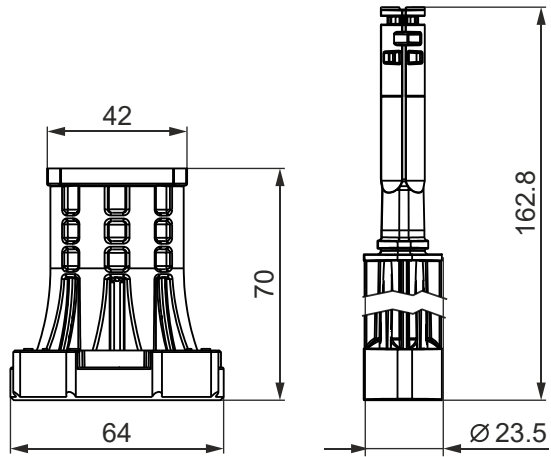

Revision numbers

| Type | Valid from rev. no. |
|--------------|---------------------|
| GMA121.9E | ..B |
| GMA321.9E | ..B |
| GMA131.9E | ..B |
| GMA161.9E | ..B |
| GMA161.9E/MO | ..C |

Document ID CM2N4658en
Edition 2022-07-07

© Siemens Switzerland Ltd, 2021
Technical specifications and availability subject to change without notice.