

Proportional solenoid valves 2-way servo-operated Type EV260B

Features

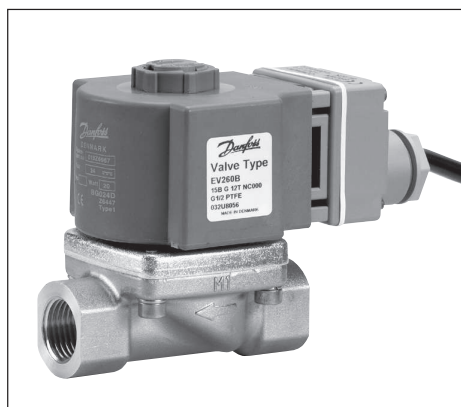

EV260B

- For stepless flow regulation in industrial plants
- Short reaction time
- Linear characteristic throughout the regulation range
- Closes on power failure (fail-safe function)
- 24 V dc supply voltage
- Standard 4-20 mA or 0-10 V dc pilot signal
- For water, oil and similar neutral liquids
- Flow range for water: 0.5-12.7 m³/h
- Coil enclosure: IP 67
- Also available with NPT thread. Please contact Danfoss.

Technical data

Installation	Vertical solenoid system is recommended
Pressure range	0.5 to 10 bar
Test pressure	15 bar
Rangeability	Better than 1:20 (5 - 100%)
Ambient temperature	-25 to +50°C
Medium temperature	-10 to +80°C
Viscosity	max. 50cSt
Materials	Valve body: Brass,..... W.no. 2.0402 Armature: Stainless Steel, W.no. 1.4105 / AISI 430 FR Armature tube: Stainless Steel, W.no. 1.4306 / AISI 304 L Spring: Stainless Steel, W.no. 1.4568 Orifice: Stainless Steel, W.no. 1.4305 / AISI 303 Spindle: Stainless Steel, W.no. 1.4105 / AISI 430 FR Valve plate: FKM Seat & guide ring: PTFE Diaphragm: PTFE O-rings: NBR / CR

Function

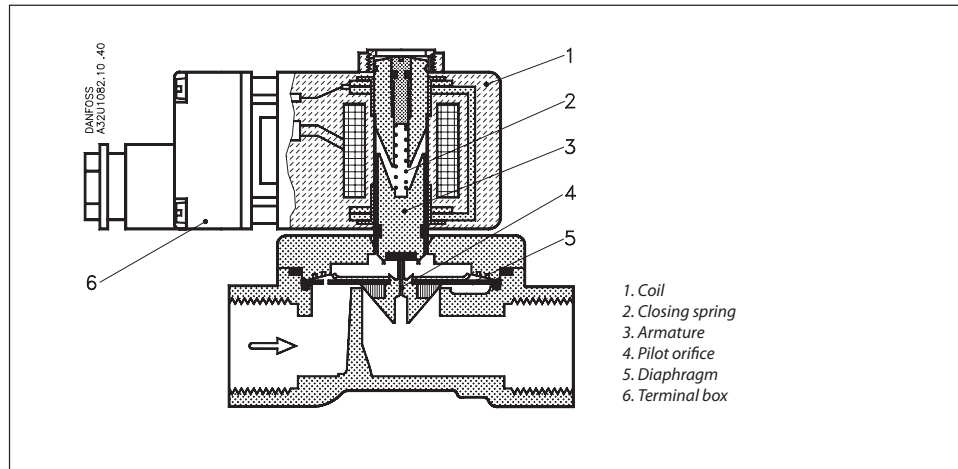

Proportional regulation of the opening and closing of the EV260B valves is achieved through stepless regulation of the coil current and thus of the pulling force of the solenoid coil.

When the coil current is increased, the pulling force of the coil (1) will at a certain point exceed the counteracting spring force of the closing spring (2). The armature (3) moves up, opening the pilot orifice (4) in the diaphragm (5), which due to the servo effect follows the armature's movement.

The valve is fully open when the coil current has reached its maximum value.

Through stepless regulation of the coil current the armature can be placed in any position in the armature tube, and the valve thus set to any position between completely closed and completely open.

The effective coil current range for EV260B proportional valves without signal converter is approx. 300-600 mA.

The EV260B valves are also available with a signal converter built in the coil's terminal box (6). The signal converter's output terminals are connected to the solenoid coil.

The signal converter regulates the coil current so that it is proportional to the input signal (pilot signal).

The pilot signal may be a
 - 0 - 10 V dc voltage signal
 or a
 - 4 - 20 mA current signal

Ordering

Valve

Con- nection ISO 228/1	Seal material	k _v value [m ³ /h]	Media temp.		Type designation		Permissible diff. pressure(bar) / Coil type			Code no. without coil	
			Min. [°C]	Max. [°C]	Main type	Specification	Min.	Max.			Standard
								BK	BM	BL	
G ¼	PTFE	0.8	-10	+80	EV260B 6B	G 14T NC000	0.5	10	10	10	032U8052
G ⅜	PTFE	0.8	-10	+80	EV260B 6B	G 38T NC000	0.5	10	10	10	032U8053
G ½	PTFE	1.3	-10	+80	EV260B 10B	G 38T NC000	0.5	10	10	10	032U8054
G ½	PTFE	1.3	-10	+80	EV260B 10B	G 12T NC000	0.5	10	10	10	032U8055
G ½	PTFE	2.1	-10	+80	EV260B 15B	G 12T NC000	0.5	10	10	10	032U8056
G ¾	PTFE	5.0	-10	+80	EV260B 20B	C 34T NC000	0.5	10	10	10	032U8057

Ordering

Coil

Description	Supply voltage	Pilot signal	Specification	Code no.
Without signal converter	24 V full wave rectified	300 - 600 mA	BK024D	018Z6987
With signal converter	21 to 30 V dc	0 - 10 V	BM024D	018Z0290
		4 - 20 mA	BL024D	018Z0291

Coil options

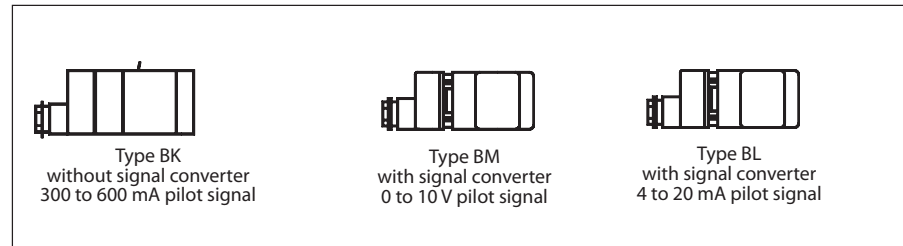

Technical data, coil

Supply voltage	Without signal converter: 24 V \pm 10%, full-wave rectified ac voltage With signal converter: 21 to 30 V dc
Pilot signal	Without signal converter: 300 to 600 mA With signal converter: 4 to 20 mA or 0 - 10 V
Coil power	max. 20 W
Insulation of coil windings	400 k Ω for 0 - 10 V pilot signal. 250 Ω for 4 to 20 mA pilot signal
Coil resistance	23.5 Ω at an ambient temperature of 20°C
Insulation of coil windings	Class H according to IEC 85
Connection	Without signal converter: Terminal box Pg 13.5 With signal converter: 2 m 3-core cable, Pg 13.5
Coil enclosure, IEC 529	IP 67
Ambient temperature	-25°C to +50°C
Duty rating	Continuous

Signal flow characteristics

Coil type BK

Without signal converter

The basic version consists of a valve with a coil for pulsating direct current. The supply voltage of 24 V DC can be established with full-wave rectified alternating current. The valve begins to open at a coil current of approx. 300 mA and is fully open at a coil current of approx. 600 mA. The ratio between coil current and flow between the two outer points is directly proportional.

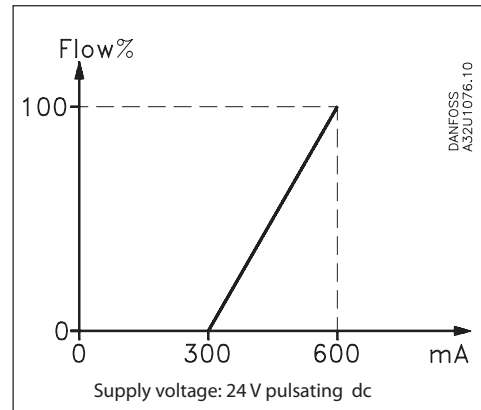

Coil type BM

With signal converter and 0-10 V pilot signal

The ratio between pilot signal and flow is directly proportional throughout the regulation range.

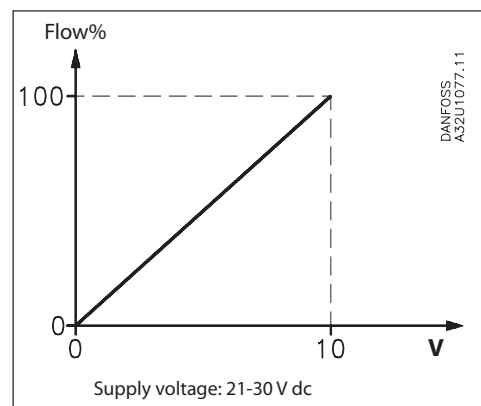

Coil type BL

With signal converter and 4-20 mA pilot signal

The ratio between pilot signal and flow is directly proportional throughout the regulation range.

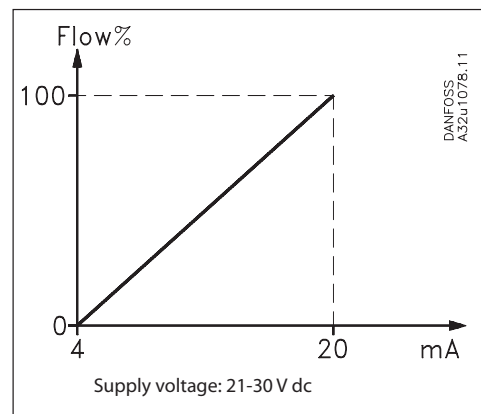

Dimensions and weight

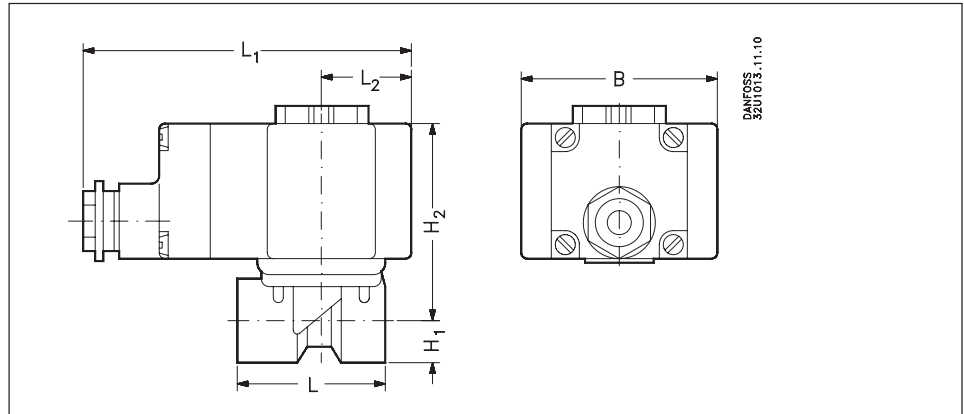

Type	L [mm]	L ₁ [mm]	L ₂ [mm]	H ₁ [mm]	H ₂ [mm]	B [mm]	Weight without signal converter [kg]	Weight with signal converter [kg]
EV260B 6B	62	112 ¹⁾	30	13	71	68	1.02	1.22
EV260B 10B	62	112 ¹⁾	30	13	71	68	1.02	1.22
EV260B 15B	81	112 ¹⁾	30	15	74	68	1.17	1.37
EV260B 20B	98	112 ¹⁾	30	18	79	68	1.71	1.91

1) With signal converter the L₁ measurement is 128 mm

Example of application

Regulation of hydraulic oil temperature

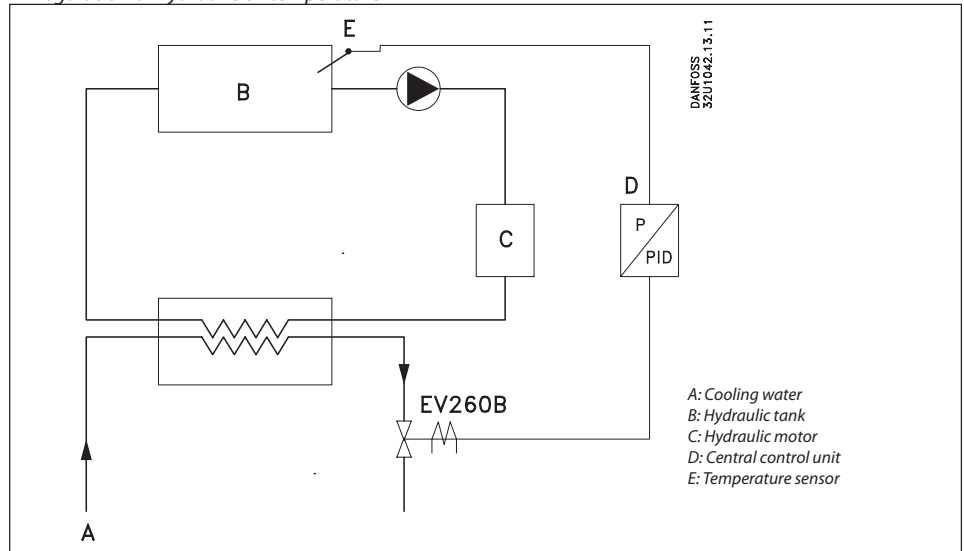

To control viscosity and thus friction, it is important to keep a constant oil temperature in hydraulic motor (C). Cooling is therefore often required.

The temperature in the oil tank (B) is measured by the electronic sensor (E). The signal from the sensor is processed by the P/PID regulator (D). The regulator emits an analogue output signal from 4-20 mA or 0-10 V dc.

The signal from the regulator is converted to a specific coil current by the EV260B valve's signal converter. The valve will then let in a specific quantity of cooling water (A) equivalent to the temperature in the oil tank and the load of the machine.

This system has the advantage that the valve closes immediately when the voltage is disconnected, shutting off the water supply without delay and thus saving water.

Capacity diagram Water at fully opened valve

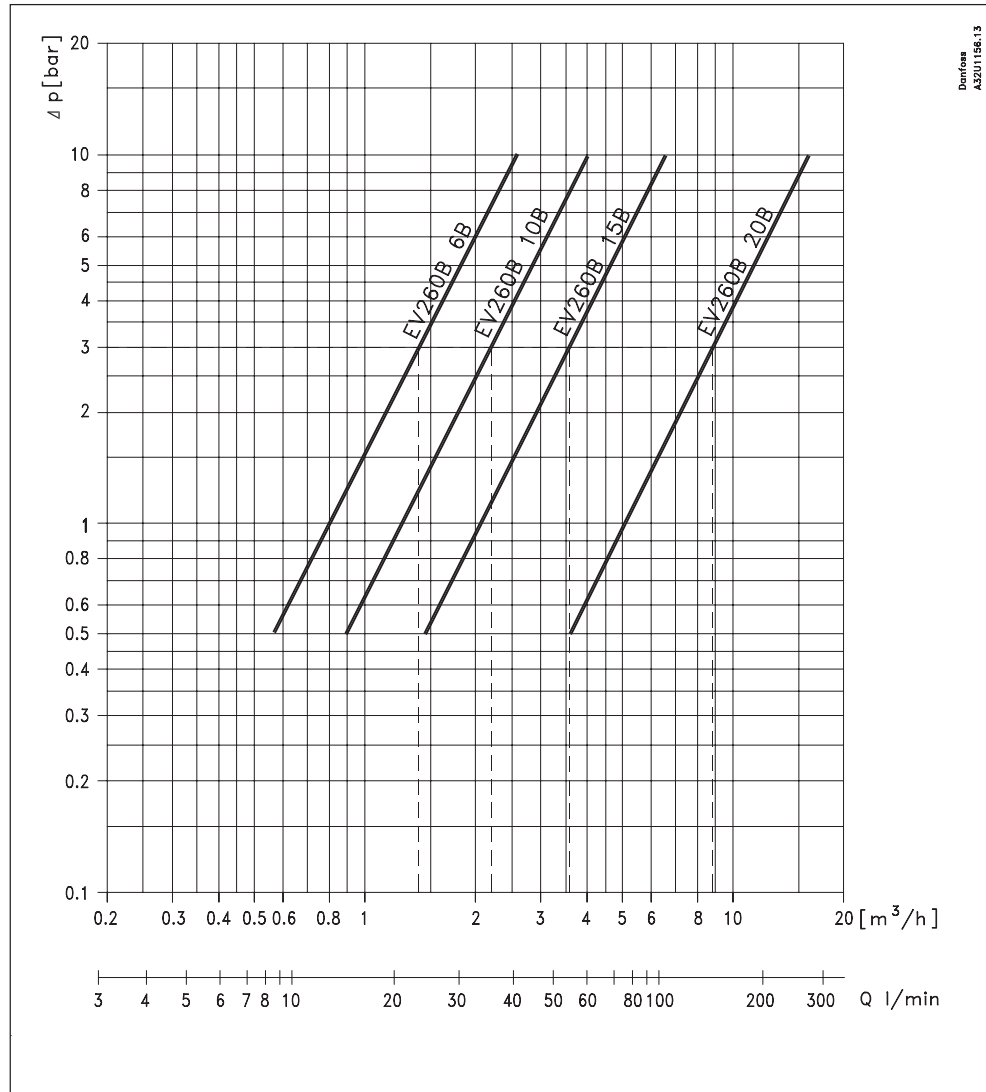

Example

Problem:

What capacity is obtainable from EV260B at a differential pressure of 3 bar?

Results:

EV260B 6B	appr. 1.4 m^3/h
EV260B 10B	appr. 2.2 m^3/h
EV260B 15B	appr. 3.6 m^3/h
EV260B 20B	appr. 8.7 m^3/h

Spare parts kit

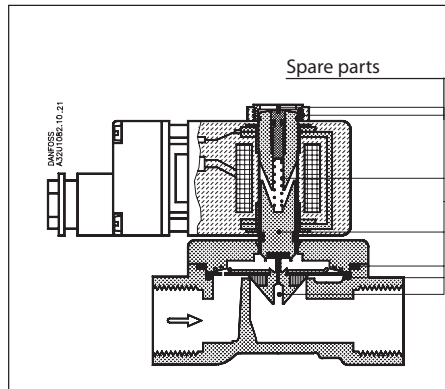

The spare parts kit comprises e.g. a locking button and nut for the coil, armature with valve plate, spring, O-rings and diaphragm.

Type	Code no.
EV260B 6B	032U8039
EV260B 10B	032U8040
EV260B 15B	032U8041
EV260B 20B	032U8042

Danfoss can accept no responsibility for possible errors in catalogues, brochures and other printed material. Danfoss reserves the right to alter its products without notice. This also applies to products already on order provided that such alterations can be made without subsequential changes being necessary in specifications already agreed.
All trademarks in this material are property of the respective companies. Danfoss and the Danfoss logotype are trademarks of Danfoss A/S. All rights reserved.
