

Solenoid valves 2/2-way servo-operated Type EV224B

Features



EV224B NC and NO

- For compressed air.
- Differential pressure: Up to 40 bar
- Ambient temperature: Up to +60°C
- Media temperature from -10°C to +60°C
- Coil enclosure: Up to IP67
- Thread connections: From G 1/2 to G 1
- Built in filter for protection of pilot system.

Technical data NC and NO

Main type	EV224B 15B	EV224B 20B	EV224B 25B
Installation	Optional, but vertical solenoid system is recommended		
Pressure range	0.3 - 40 bar		
Max. test pressure	64 bar		
Time to open ¹⁾	40 ms	40 ms	50 ms
Time to close ¹⁾	150 ms	150 ms	150 ms
Ambient temperature	Coil type: BB 10 W ac/18 W dc ²⁾ Up to +60°C Coil type: BE 10 W ac/ 18 W dc ²⁾ (IP67) Up to +60°C Coil type: BG 12 W ac/ 20 W dc Up to +60°C		
Media temperature	-10 to +60°C		
Materials	Valve body: Brass, W.no. 2.0402 Armature: Stainless steel, W.no. 1.4105 / AISI 430FR Armature tube: Stainless steel, W.no. 1.4306 / AISI 304L Armature stop: Stainless steel, W.no. 1.4105 / AISI 430FR Diaphragm valve cone: Stainless steel, W.no. 1.4404 / AISI 316 L Springs: Stainless steel, W.no. 1.4310 / AISI 301 O-rings: NBR Valve plate: NC : NBR / NO : PTFE Diaphragm: NBR		

¹⁾The times are indicative and apply to air. The exact times will depend on the pressure conditions. Closing times can be changed by replacement of the equalising orifice.

²⁾With 18 W dc max. 30 bar.

Function NC

Coil voltage disconnected (closed):

When the voltage is disconnected, the valve plate (3) is pressed down against the pilot orifice (4) by the armature spring (2). The pressure across the diaphragm (5) is built up via the equalising orifice (7). The diaphragm closes the main orifice (6) as soon as the pressure across the diaphragm is equivalent to the inlet pressure. The valve will be closed for as long as the voltage to the coil is disconnected.

Coil voltage connected (open):

When voltage is applied to the coil (1), the pilot orifice (4) is opened. As the pilot orifice is larger than the equalising orifice (7), the pressure across the diaphragm (5) drops and therefore it is lifted clear of the main orifice (6). The valve is now open for unimpeded flow and will be open for as long as the minimum differential pressure across the valve is maintained, and for as long as there is voltage to the coil.

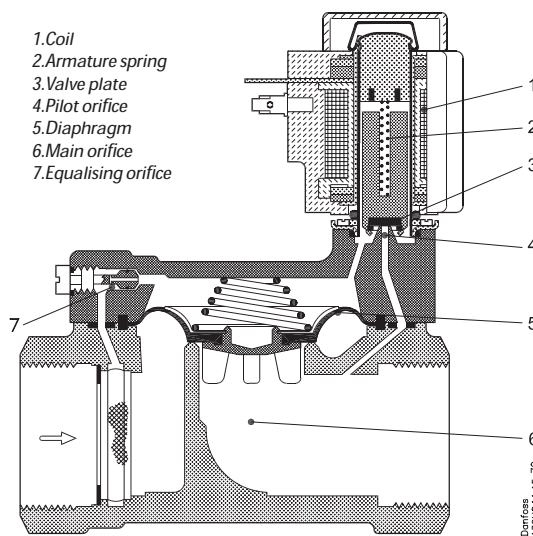

Ordering NC

Connection ISO 228/1	Seal material	k _v value [m ³ /h]	Media temp.		Type designation		Code no. without coil	Pressure range Coil types BB - BE - BG	
			Min. [°C]	Max. [°C]	Main type	Specification		Min. [bar]	Max. [bar]
G 1/2	NBR	4	-10	+60	EV224B 15B	G12N NC000	032U8360	0.3	40
G 3/4	NBR	8	-10	+60	EV224B 20B	G34N NC000	032U8362	0.3	40
G 1	NBR	11	-10	+60	EV224B 25B	G1N NC000	032U8364	0.3	40

Function NO

Coil voltage disconnected (open):

When the voltage to the coil (2) is disconnected, the pilot orifice (4) is open.

As the pilot orifice is larger than the equalising orifice (7), the pressure across the diaphragm (5) drops and therefore it is lifted clear of the main orifice (6). The valve will be open for as long as the minimum differential pressure across the valve is maintained, and for as long as the voltage to the coil is disconnected.

Coil voltage connected (closed):

When voltage is applied to the coil, the valve plate (3) is pressed down against the pilot orifice (4). The pressure across the diaphragm (5) is built up via the equalising orifice (7). The diaphragm closes the main orifice (6) as soon as the pressure across the diaphragm is equivalent to the inlet pressure. The valve will be closed for as long as there is voltage to the coil.

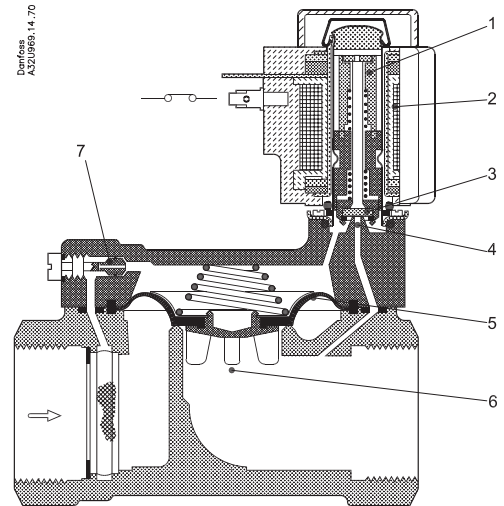

1. Armature
2. Coil
3. Valve plate
4. Pilot orifice
5. Diaphragm
6. Main orifice
7. Equalising orifice

Ordering NO

Connection ISO 228/1	Seal material	k _v value [m ³ /h]	Media temp.		Type designation		Code no. without coil	Pressure range Coil types BB - BE - BG	
			Min. [°C]	Max. [°C]	Main type	Specification		Min. [bar]	Max. [bar]
G 1/2	NBR	4	-10	+60	EV224B 15B	G12N NO000	032U8361	0.3	40
G 3/4	NBR	8	-10	+60	EV224B 20B	G34N NO000	032U8363	0.3	40
G 1	NBR	11	-10	+60	EV224B 25B	G1N NO000	032U8365	0.3	40

Coil options

Type: BB
10 W ac
18 W dc

Type: BE (IP 67)
10 W ac
18 W dc

Type: BG
12 W ac
20 W dc

Danfoss also offers hum-free coils for noise sensitive applications and EEx m II T4 coils for use in explosion risk areas - please see coil data sheet DKACV.PD.600.A

Ordering Coils

See separate data sheet for coils IC, PD.600.A

Dimensions and weight, NC and NO

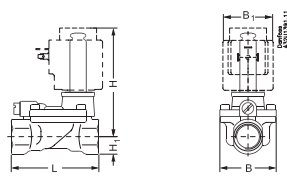

Type	L [mm]	B [mm]	B ₁ [mm] Coil type		H ₁ [mm]	H [mm]	Weight without Coil [Kg]
			BB/BE	BG			
EV224B 15B	80.0	52.0	46	68	15.0	99.0	0.8
EV224B 20B	90.0	58.0	46	68	18.0	103.0	1.0
EV224B 25B	109.0	70.0	46	68	22.0	113.0	1.4

Spare parts kit NC

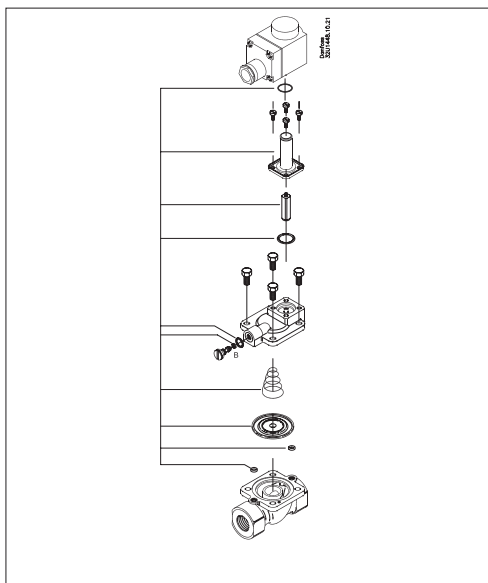

The kit comprises a O-ring for coil, armature with valve plate and spring, O-ring for the armature tube, spring and diaphragm, two O-rings for the pilot system, and an O-ring and gasket for the equalising orifice.

Type	Seal material	Code no.
EV224B 15B	NBR	032U6156
EV224B 20B	NBR	032U6158
EV224B 25B	NBR	032U6160

Spare parts kit NO

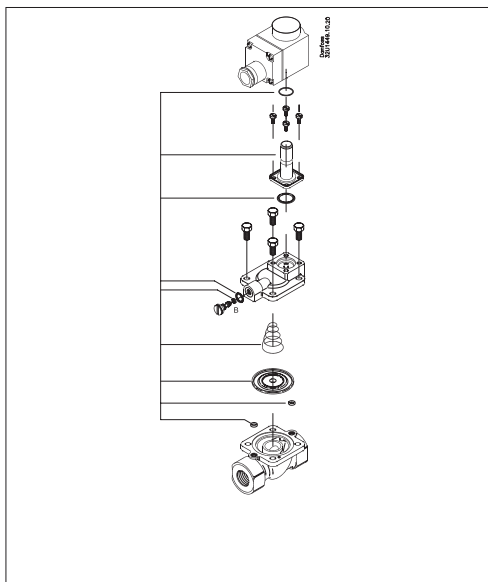

The kit comprises a O-ring for coil, Armature unit assembly, O-ring for the armature unit, spring and diaphragm, two O-rings for the pilot system, and an O-ring and gasket for the equalising orifice.

Type	Seal material	Code no.
EV224B 15B	NBR	032U6157
EV224B 20B	NBR	032U6159
EV224B 25B	NBR	032U6161

Options

- NC manuel override with screw
- NC manuel override with pushbutton

Note

Please contact Danfoss concerning media resistance

Danfoss can accept no responsibility for possible errors in catalogues, brochures and other printed material. Danfoss reserves the right to alter its products without notice. This also applies to products already on order provided that such alterations can be made without subsequential changes being necessary in specifications already agreed. All trademarks in this material are property of the respective companies. Danfoss and the Danfoss logotype are trademarks of Danfoss A/S. All rights reserved.