

Solenoid valves 2/2-way servo-operated Type EV220B 65-100

Features



EV220B CI

- For robust industrial application, such as supply
- For water and similar neutral media
- Flow range for water: 25 to 400 m³/h
- Differential pressure: Up to 10 bar
- Viscosity: Up to 50 cSt
- Ambient temperature: Up to +80°C
- Coil enclosure: Up to IP 67
- Flange connections: 2 1/2, 3 and 4"
- Water hammer damped
- Built-in filter for protection of pilot system

Installation	Optional, but vertical solenoid system is recommended.		
Pressure range	0.25 - 10 bar		
Max. test pressure	15 bar		
Time to open ¹⁾	DN 65: approx. 5 s	DN 80: approx. 5 s	DN 100: approx. 5 s
Time to close ¹⁾	DN 65: approx. 7 s	DN 80: approx. 15 s	DN 100: approx. 29 s
Ambient temperature	max. +80°C (depending on coil type, see data for the coil selected)		
Medium temperature	-25 to +90°C		
Viscosity	max. 50 cSt		
Materials	Valve body: Cast iron (GG 20), W.no. 0.6020 Armature/tube stop: Stainless steel, W.no. 1.4105/ AISI 430L Armature tube: Stainless steel, W. no. 1.4306/ AISI 304L Springs: Stainless steel, W. no. 1.4310/ AISI 301 Sleeve, etc.: EPDM, NBR, PTFE (EPDM versions) NBR, PTFE (NBR versions)		

¹⁾ The times are indicative and apply to water.
The exact times will depend on the pressure conditions.

Function

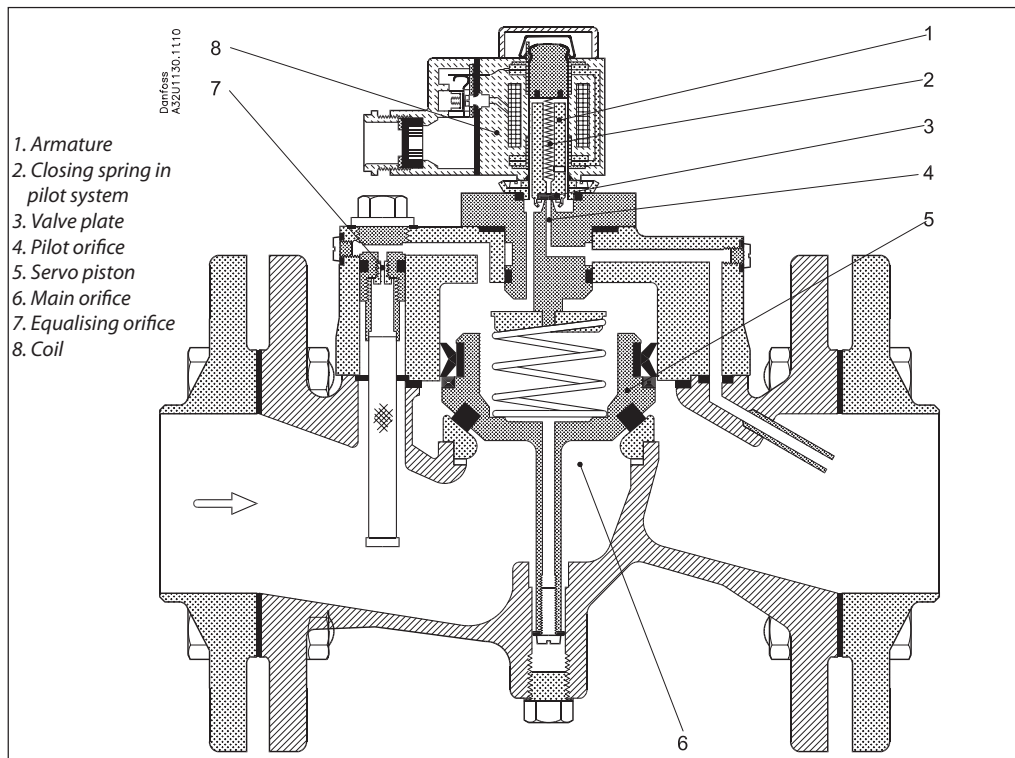

Coil voltage disconnected (closed):
 When the voltage is disconnected, the valve plate (3) is pressed down against the pilot orifice (4) by the pilot system's closing spring (2). The pressure across the servo piston (5) is built up via the equalising orifice (7). The servo piston closes the main orifice (6) as soon as the pressure across the piston is equivalent to the inlet pressure. The valve will be closed for as long as the voltage to the coil is disconnected.

Coil voltage connected (open):
 When voltage is applied to the coil (8), the armature (1) and the valve plate (3) are lifted clear of the pilot orifice (4). As the pilot orifice is larger than the equalising orifice (7), the pressure across the servo piston (5) drops and therefore it is lifted clear of the main orifice (6). The valve will be open for as long as the minimum differential pressure across the valve is maintained, and for as long as there is voltage to the coil.

Ordering - valve body with flange bolts and gaskets

Flange connection	k _v -value [m ³ /h]	Seal material	Valve type		Code no. without coil	Permissible differential pressure		Suitable coil types
			Main type	Specification		min. [bar]	max. [bar]	
2 1/2	50	EPDM	EV220B 65 CI	FL 10E NC000	016D6065	0.25	10	BB, BE and BG
2 1/2	50	NBR	EV220B 65 CI	FL 10N NC000	016D3330	0.25	10	BB, BE and BG
3	75	EPDM	EV220B 80 CI	FL 10E NC000	016D6080	0.25	10	BB, BE and BG
3	75	NBR	EV220B 80 CI	FL 10N NC000	016D3331	0.25	10	BB, BE and BG
4	130	EPDM	EV220B 100 CI	FL 10E NC000	016D6100	0.25	10	BB, BE and BG

Ordering of flange set

	Connection	Type	Code no.
	2 1/2 weld type 11 according to DIN EN 1092-1	EV220B 65 CI	027N3065
	G 2 1/2 type 13 according to DIN EN 1092-1	EV220B 65 CI	027G3065
	3 weld type 11 according to DIN EN 1092-1	EV220B 80 CI	027N3080
	G 3 type 13 according to DIN EN 1092-1	EV220B 80 CI	027G3080
	4 weld type 11 according to DIN EN 1092-1	EV220B 100 CI	027N3100
	G 4 type 13 according to DIN EN 1092-1	EV220B 100 CI	027G3100

Each set contains two flanges

Coil options

Type: BB 10 W ac 18W dc	Type: BE (IP67) 10 W ac 18W dc	Type: BG 12 W ac 20W dc

Ordering coils

See separate data sheet for coils IC.PD. 600.A

Dimensions and weight

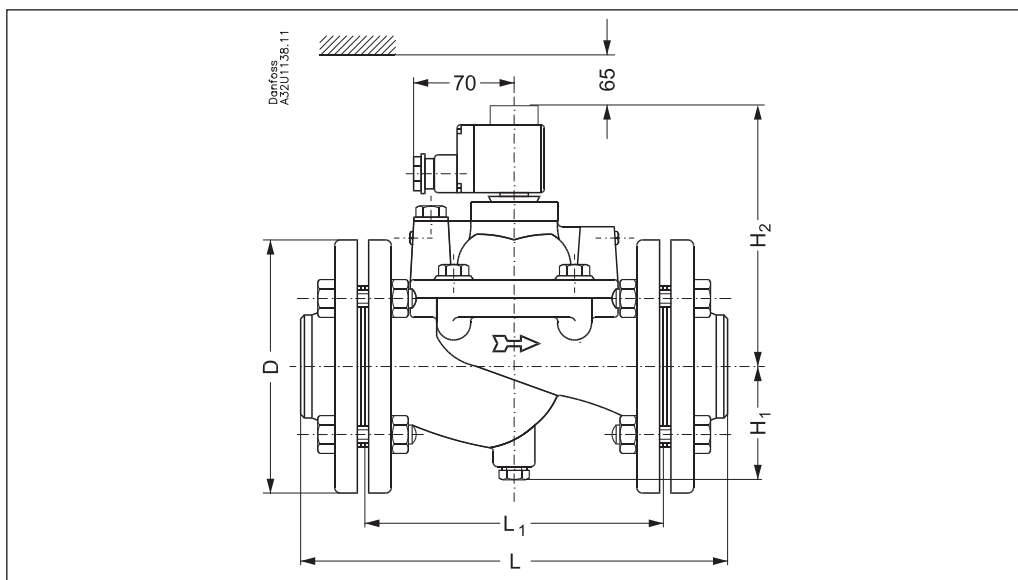

Main type	L [mm]	L ₁ [mm]	Coil width [mm]		ØD [mm]	H ₁ [mm]	H ₂ [mm]	Weight without coil [kg]
			10 W ac	20 W dc				
EV220B 65 CI	320	224	46	66	185	85	185	24
EV220B 80 CI	370	265	46	66	200	93	215	34
EV220B 100 CI	430	315	46	66	220	103	240	44

Spare parts kit and seal kit

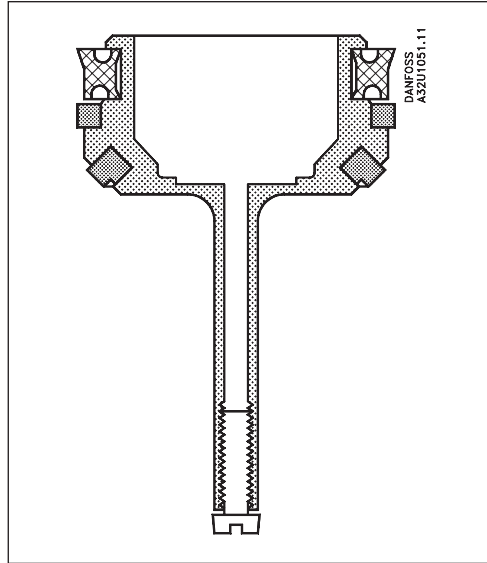

Spare parts kit

The spare parts kit comprises an assembled servo piston, assembled armature and various seals.

Valve	Code no.	
	Seal material	
	EPDM	NBR
EV220B 65	016D0078	016D0095
EV220B 80	016D0079	016D0096
EV220B 100	016D0080	016D0097

Seal kit

Comprises all relevant seals.

Valve	Code no.	
	Seal material	
	EPDM	NBR
EV220B 65	016D0075	016D0084
EV220B 80	016D0076	016D0085
EV220B 100	016D0077	016D0086

Filter kit

Comprises a complete filter kit and relevant seals.

Valve	Code no.
EV220B 65	016D0092
EV220B 80/100	016D0093

^a Danfoss can accept no responsibility for possible errors in catalogues, brochures and other printed material. Danfoss reserves the right to alter its products without notice. This also applies to products already on order provided that such alterations can be made without subsequential changes being necessary in specifications already agreed. All trademarks in this material are property of the respective companies. Danfoss and the Danfoss logotype are trademarks of Danfoss A/S. All rights reserved.