

Solenoid valves 2/2-way direct operated type EV210B

Technical leaflet

Contents

	Page
EV210B 1.5-25B Normally Closed (NC)	
Introduction.....	3
Features.....	3
Approvals.....	3
Technical data.....	4
Function.....	4
Ordering.....	5
Coil options.....	6
Dimensions and weight.....	6
EV210B 1.5-4.5B Normally Open (NO)	
Features.....	7
Technical data.....	7
Function.....	7
Ordering.....	8
Dimensions and weight.....	8
EV210B 1.5-4.5SS Normally Closed (NC)	
Features.....	9
Technical data.....	9
Function.....	9
Ordering.....	10
Dimensions and weight.....	10
Accessories.....	11
Spare parts kit.....	11

Introduction

EV210B covers a wide range of direct-operated 2/2-way solenoid valves for universal use. EV210B is a real robust valve program with high performance and can be used in all kind of tough working conditions.

EV210B valves are supplied complete or as separate components i.e. valve body and coil, can be ordered separately.



Features

- For robust industrial applications, such as control and dosage.
- For water, oil, compressed air and similar neutral media.
- Differential pressure: Up to 30 Bar
- Ambient temperature: Up to +80°C
- Coil enclosure : Up to IP 67
- Tread connections: G 1/8 to G 1
- Viscosity: Up to 50 cSt
- k_v value up to 8.0 m³/h
- Also available with NPT thread. Please contact Danfoss.
- The valves can be used for rough vacuum.

Approvals

EPDM versions up to DN 3.0 are WRAS approved.

Pressure Equipment Directive (PED) 97/23/EC



Versions with UL approval can be supplied to order.

ATTESTATION DE CONFORMITE SANITAIRE , ACS	
Body material B = Brass with EPDM seal material	Body material SS= Stainless steel
EV210B 1,5B EV210B 2 B EV210B 3B EV210B 4,5B EV210B 6B EV210B 8B EV210B 10B	EV210B 1,5 SS EV210B 2 SS EV210B 3 SS EV210B 4,5 SS

PAŃSTWOWY ZAKŁAD HIGIENY, PZH
Body material B = Brass with EPDM seal material
EV210B 1,5B EV210B 2 B EV210B 3B

Technical data

Type	EV210B 1,5 - 2B	EV210B 3 - 4,5B	EV210B 6B	EV210B 8 - 10B	EV210B 15B	EV210B 20B	EV210B 25B
Installation	Optional, but vertical solenoid system is recommended						
Pressure range	0 - 30 bar						
Max. test pressure	50 bar	50 bar	50 bar	50bar	12 bar	12 bar	12 bar
Tightness	Internally: Better than 8.3 x 10 ⁻² mbar l/sec (5ccm air per min.) Externally: Better than 1 x 10 ⁻³ mbar l/sec (100% H ₂)						
Tme to open ¹⁾	10 ms	20 ms	20ms	20 ms	30 ms	40 ms	40 ms
Time to close ¹⁾	20 ms	20 ms	20 ms	30 ms	50ms	50 ms	70 ms
Ambeint temperature	Max. +80°C (depending on coil type, see for the coil selected)						
Medium temperature	See specific valve data						
Viscosity	Max. 50 cSt						
Materials	Valve body: Brass,.....W.no.2.0402 Armature: Stainless Steel, W.no.1.4105 / ASIS 430FR Armature tube:Stainless Steel, W.no.1.4306 / ASIS 304L Armature stop: Stainless Steel, W.no.1.4105 / ASIS 430FR Springs: Stainless Steel, W.no.1.4306 / ASIS 301 Seal material: See specific data under ordering						

1) The times are indicative and apply to water. The exact times will depend on the pressure conditions.

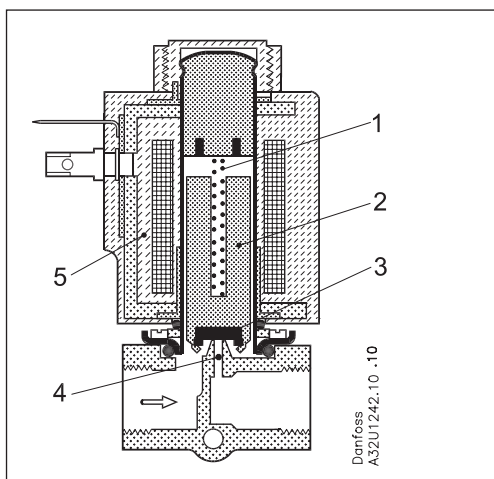
Function

Coil voltage disconnected (closed):

When the voltage to the coil (5) is disconnected, the armature (2) with the valve plate (3) is pressed down against the valve orifice (4) by the closing spring (1) and the medium's pressure.

The valve will be closed for as long as the voltage to the coil is disconnected.

Coil voltage connected (open):

When voltage is applied to the coil(5), the armature (2) with the valve plate (3) is lifted clear of the valve orifice (4).

The valve is now open for unimpeded flow and will be open for as long as there is voltage to the coil.

Ordering

**EV210B NC versions for AC and DC current:
Brass bodies**

Conn. ISO 228/1	Seal material	k _v value [m ³ /h]	DN [mm]	Media temp		Type designation		Code no. without coil	Permissible differential pressure(bar)/Coil type ²⁾							
				Min °C	Max. °C	Main type	Specification		BA		BD		BB		BG	
									9W a.c.	15W d.c.	15W a.c.	10W a.c.	18W d.c.	12W a.c.	20W d.c.	
G 1/8	EPDM ¹⁾ FKM	0.08 0.08	1.5 1.5	-30 -10	+120 +100	EV210B 1.5B EV210B 1.5B	G 18E NC000 G 18F NC000	032U5701 032U5702	30 30	30 30	30 30	30 30	30 30	30 30	30 30	
	EPDM ¹⁾ FKM	0.15 0.15	2.0 2.0	-30 -10	+120 +100	EV210B 2.0B EV210B 2.0B	G 18E NC000 G 18F NC000	032U5714 032U5704	30 30	20 20	30 30	30 30	30 30	30 30	30 30	
	EPDM ¹⁾ FKM	0.30 0.30	3.0 3.0	-30 -10	+120 +100	EV210B 3.0B EV210B 3.0B	G 18E NC000 G 18F NC000	032U5705 032U5706	15 15	9 9	24 24	20 20	13 13	30 30	25 25	
G 1/4	EPDM ¹⁾ FKM	0.08 0.08	1.5 1.5	-30 -10	+120 +100	EV210B 1.5B EV210B 1.5B	G 14E NC000 G 14F NC000	032U3628 032U3629	30 30	30 30	30 30	30 30	30 30	30 30	30 30	
	EPDM ¹⁾ FKM	0.15 0.15	2.0 2.0	-30 -10	+120 +100	EV210B 2.0B EV210B 2.0B	G 14E NC000 G 14F NC000	032U5707 032U5708	30 30	20 20	30 30	30 30	30 30	30 30	30 30	
	EPDM ¹⁾ FKM	0.30 0.30	3.0 3.0	-30 -10	+120 +100	EV210B 3.0B EV210B 3.0B	G 14E NC000 G 14F NC000	032U5709 032U5710	15 15	9 9	24 24	20 20	13 13	30 30	25 25.0	
	EPDM ¹⁾ FKM	0.55 0.55	4.5 4.5	-30 -10	+120 +100	EV210B 4.5B EV210B 4.5B	G 14E NC000 G 14F NC000	032U3600 032U3601	8.0 8.0	3.5 3.5	12 12	10 10	4.5 4.5	13 13	9 9	
	EPDM FKM	0.70 0.70	6.0 6.0	-30 -10	+120 +100	EV210B 6.0B EV210B 6.0B	G 14E NC000 G 14F NC000	032U3602 032U3603	2.5 2.5	1.0 1.0	3.3 3.3	4.0 4.0	2.0 2.0	6 6	4.5 4.5	
G 3/8	EPDM ¹⁾ FKM	0.30 0.30	3.0 3.0	-30 -10	+120 +100	EV210B 3.0B EV210B 3.0B	G 38E NC000 G 38F NC000	032U3642 032U3643	15 15	9 9	24 24	20 20	13 13	30 30	25 25.0	
	EPDM ¹⁾ FKM	0.55 0.55	4.5 4.5	-30 -10	+120 +100	EV210B 4.5B EV210B 4.5B	G 38E NC000 G 38F NC000	032U3605 032U3606	8.0 8.0	3.5 3.5	12 12	10 10	4.5 4.5	13 13	9 9	
	EPDM FKM	0.70 0.70	6.0 6.0	-30 -10	+120 +100	EV210B 6.0B EV210B 6.0B	G 38E NC000 G 38F NC000	032U3607 032U3608	2.5 2.5	1.0 1.0	3.3 3.3	4.0 4.0	2.0 2.0	6 6	4.5 4.5	
	EPDM FKM	1.00 1.00	8.0 8.0	-30 -10	+120 +100	EV210B 8.0B EV210B 8.0B	G 38E NC000 G 38F NC000	032U3609 032U3610	1.5 1.5	0.5 0.5	2.0 2.0	2.0 2.0	1.2 1.2	3 3	2.5 2.5	
	EPDM FKM	1.50 1.50	10 10	-30 -10	+120 +100	EV210B 10B EV210B 10B	G 38E NC000 G 38F NC000	032U3611 032U3612	0.8 0.8	0.3 0.3	1.1 1.1	1.2 1.2	0.6 0.6	1.6 1.6	1.3 1.3	
	EPDM FKM	2.50 2.50	15 15	-30 -10	+120 +100	EV210B 15BD EV210B 15BD	G 38E NC000 G 38F NC000	032U3613 032U3614	0.25 0.25	- -	0.4 0.4	0.3 0.3	0.15 0.15	0.45 0.45	0.4 0.4	
G 1/2	EPDM FKM	1.00 1.00	8.0 8.0	-30 -10	+120 +100	EV210B 8.0B EV210B 8.0B	G 12E NC000 G 12F NC000	032U3615 032U3616	1.5 1.5	0.5 0.5	2.0 2.0	2.0 2.0	1.2 1.2	3 3	2.5 2.5	
	EPDM FKM	1.50 1.50	10 10	-30 -10	+120 +100	EV210B 10B EV210B 10B	G 12E NC000 G 12F NC000	032U3617 032U3618	0.8 0.8	0.3 0.3	1.1 1.1	1.2 1.2	0.6 0.6	1.6 1.6	1.3 1.3	
	EPDM FKM	2.85 2.85	15 15	-30 -10	+120 +100	EV210B 15BD EV210B 15BD	G 12E NC000 G 12F NC000	032U3619 032U3620	0.25 0.25	- -	0.4 0.4	0.3 0.3	0.15 0.15	0.45 0.45	0.4 0.4	
G 3/4	EPDM FKM	4.50 4.50	20 20	-30 -10	+120 +100	EV210B 20BD EV210B 20BD	G 34E NC000 G 34F NC000	032U3621 032U3622	- -	- -	- -	0.28 0.28	0.12 0.12	0.4 0.4	0.35 0.35	
G 1	EPDM FKM	8.0 8.0	25 25	-30 -10	+120 +100	EV210B 25BD EV210B 25BD	G 1E NC000 G 1F NC000	032U3623 032U3624	- -	- -	- -	0.25 0.25	0.09 0.09	0.35 0.35	0.2 0.2	

1) 140°C / 3.6 bar low pressure steam, orifice DN 1.5 - 4.5.

- Low pressure steam: DN 1.5 - 3 Use coil type BB or BG.

DN 4.5 Use coil type BG

2) Pressure range can be extended to use in rough vacuum, typically up to 99% vacuum (10mbar), depending on the application.

Coil options

Type BA: 9 W ac
15 W dc
 Type BD: 15 W ac
 Type BB: 10 W ac
18 W dc
 Type BE(IP67): 10 W ac
18 W dc
 Type BG: 12 W ac
20 W dc

Danfoss also offers hum-free coils for noise sensitive applications and EEx m II T4 coils for use in explosion risk areas - please see coil data sheet IC.PD.600.A

Ordering coils

See separate data sheet for coils IC.PD.600.A

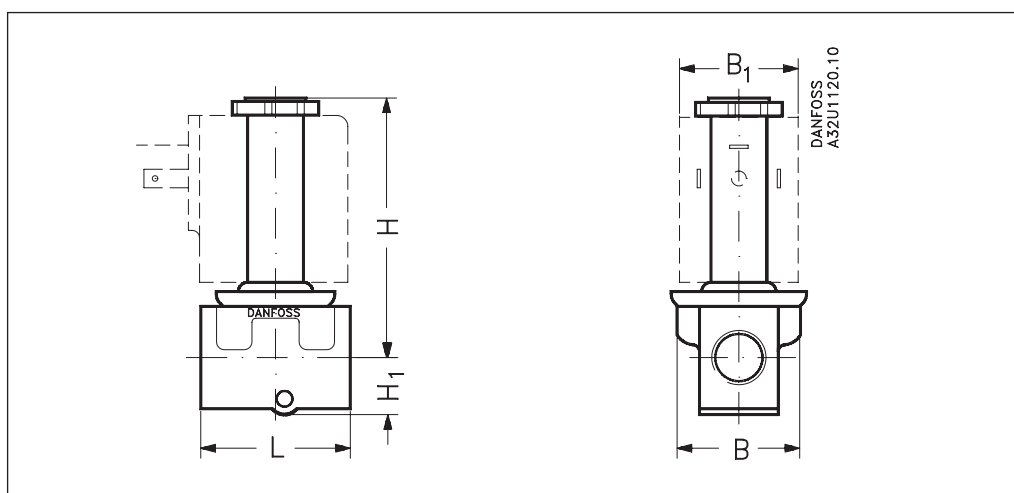
Dimensions and weight

Type	L [mm]	B [mm]	B ₁ [mm]			H ₁ [mm]	H [mm]	Weight without coil [kg]
			Coil type BA/BD	Coil type BB/BE	Coil type BG			
EV210B 1.5/2B	35.0	34	32	46	66	12.0	70.0	0.15
EV210B 3/4.5	38.0	34	32	46	66	11.0	70.0	0.20
EV210B 6B	45.5	34	32	46	66	15.5	72.5	0.22
EV210B 8/10B	49.0	34	32	46	66	15.5	72.5	0.29
EV210B 15B	58.0	53.0	32	46	66	12.5	92.5	0.45
EV210B 20B	90.0	58.0	32	46	66	18.0	92.0	1.10
EV210B 25B	90.0	58.0	32	46	66	23.0	96.0	1.10

Features



- For robust industrial application, such as control and dosage.
- For water, oil, compressed air and similar neutral media.
- k_v value up to 0.55 m³/h
- Differential pressure: Up to 30 Bar
- Viscosity: Up to 50 cSt
- Ambient temperature: Up to +80°C
- Coil enclosure: Up to IP67
- Thread connections: G 1/8 and G 1/4
- Also available with NPT tread. Please contact Danfoss.
- The valves can be used for rough vacuum.

Technical data

Installation	Optional, but vertical solenoid system is recommended
Pressure range	0 to 30 bar
Max. test pressure	50 bar
Tightness	Internally: Better than 8.3 x 10 ⁻² mbar l/sec (5ccm air per min) Externally: Better than 1 x 10 ⁻³ mbar l/sec (100%He)
Time to close ¹⁾	20 ms
Time to open ¹⁾	10 - 30 ms
Ambient temperature	max. +80°C (depending on the coil type, see data for the coil selected)
Medium temperature	See specific valve data
Viscosity	max. 50 cSt
Materials	Valve body: Brass,..... W.no. 2.0402 Armature: Stainless steel, W.no. 1.4105/AISI 430FR Armature tube: Stainless steel, W.no. 1.4306/AISI 304L Armature stop: Stainless steel, W.no. 1.4105/AISI 430FR Springs: Stainless steel, W.no. 1.4310/AISI 301 Seal material: See specific valve data

1) The times are indicative and apply to water. The exact times will depend on the pressure conditions.

Function

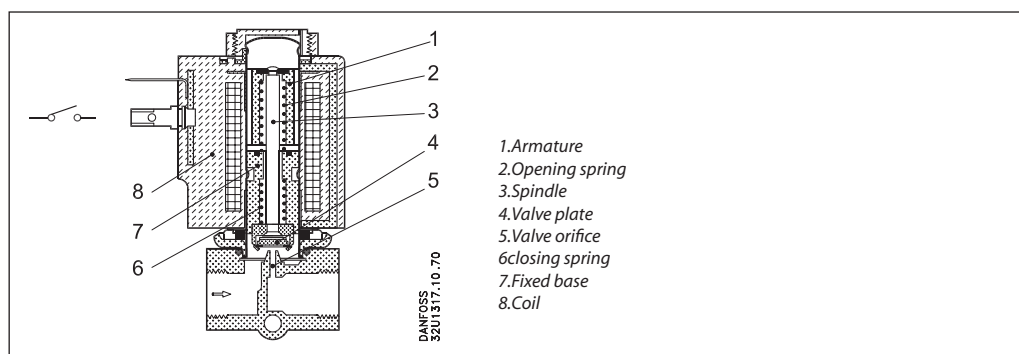

Coil voltage connected (open):
When the voltage to the coil (8) is disconnected, the valve orifice (5) is open, the opening spring (2) lifting the spindle (3) with the valve plate (4) clear of the orifice. The valve will be open for as long as the supply voltage to the coil is disconnected.

Coil voltage connected (closed):
When voltage is applied to the coil (8), the magnetic field draws the valve's armature (1) down to touch the fixed base (7). The spindle (3) with the valve plate (4) is now pressed down against the valve orifice (5) by the closing spring (6). The valve will be closed for as long as there is voltage to the coil.

Ordering
**EV210B NO versions for AC and DC current:
Brass bodies**

Conn. ISO 228/1	Seal material	k _v value [m ³ /h]	DN [mm]	Media temp		Type designation		Code no. without coil	Permissible differential pressure(bar)/Coil type ²⁾							
				Min °C	Max. °C	Main type	Specification		BA		BD		BB		BG	
									9W a.c.	15W d.c.	15W a.c.	10W a.c.	18W d.c.	12W a.c.	20W d.c.	
G 1/8	EPDM ¹⁾ FKM	0.08 0.08	1.5 1.5	-30 -10	+120 +100	EV210B 1.5B EV210B 1.5B	G 18 E NO000 G 18F NO000	032U3630 032U3631	30	30	30	30	30	30	30	
									30	30	30	30	30	30	30	
	EPDM ¹⁾ FKM	0.15 0.15	2.0 2.0	-30 -10	+120 +100	EV210B 2.0B EV210B 2.0B	G 18 E NO000 G 18F NO000	032U3632 032U3633	12	12	12	12	12	12	12	
G 1/4	EPDM ¹⁾ FKM	0.30 0.30	3.0 3.0	-30 -10	+120 +100	EV210B 3.0B EV210B 3.0B	G 18 E NO000 G 18F NO000	032U3634 032U3635	5	5	5	5	5	5	5	
									5	5	5	5	5	5	5	
	EPDM ¹⁾ FKM	0.15 0.15	2.0 2.0	-30 -10	+120 +100	EV210B 2.0B EV210B 2.0B	G 14 E NO000 G 14F NO000	032U3636 032U3637	12	12	12	12	12	12	12	
G 1/4	EPDM ¹⁾ FKM	0.30 0.30	3.0 3.0	-30 -10	+120 +100	EV210B 3.0B EV210B 3.0B	G 14 E NO000 G 14F NO000	032U3638 032U3639	5	5	5	5	5	5	5	
									5	5	5	5	5	5	5	
	EPDM ¹⁾ FKM	0.55 0.55	4.5 4.5	-30 -10	+120 +100	EV210B 4.5B EV210B 4.5B	G 14 E NO000 G 14F NO000	032U3640 032U3641	2	2	2	2	2	2	2	
									2	2	2	2	2	2	2	

1) 140°C / 3.6 bar low pressure steam, orifice DN 1.5 - 4.5.

- Low pressure steam: DN 1.5 - 3 Use coil type BB or BG.

DN 4.5 Use coil type BG

2) Pressure range can be extended to use in rough vacuum, typically up to 99% vacuum (10mbar), depending on the application.

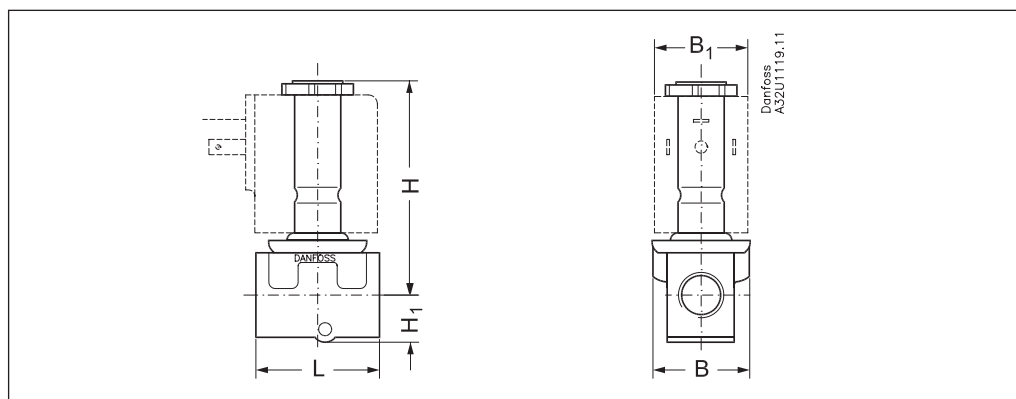
Dimensions and weight

Type	L [mm]	B [mm]	B ₁ [mm]			H ₁ [mm]	H [mm]	Weight without coil [kg]
			Coil type BA/BD	Coil type BB/BE	Coil type BG			
EV210B 1.5/2B NO	35.0	34.0	32	46	66	12.0	70.0	0.15
EV210B 3/4.5B NO	38.0	34.0	32	46	66	11.0	70.0	0.20

Features



- For industrial application, such as control and dosage.
- For neutral and aggressive liquids and gasses. Contact Danfoss if you are in doubt about the suitability of the valve for the medium in question.
- Ambient temperature: Up to +80°C
- Coil enclosure: Up to IP67
- Thread connections: G 1/8 and G 1/4
- Viscosity: Up to 50cSt
- k_v values up to 0.55 m³/h
- Differential pressure: Up to 30 bar
- The valves can be used for rough vacuum.

Technical data

Installation	Optional, but vertical solenoid system is recommended
Pressure range	0 to 30 bar
Max. test pressure	50 bar
Tightness	Internally: Better than 8.3 x 10 ⁻² mbar l/sec (5ccm air per min) Externally: Better than 1 x 10 ⁻³ mbar l/sec (100%He)
Time to open ¹⁾	10 - 30 ms
Time to close ¹⁾	20ms
Ambient temperature	max. +80°C
Medium temperature	See specific valve data
Viscosity	max. 50 cSt
Materials	Valve body: Stainless steel, W.no. 1.4404 /AISI 316L Armature: Stainless steel, W.no. 1.4105/AISI 430FR Armature tube: Stainless steel, W.no. 1.4306/AISI 304L Armature stop: Stainless steel, W.no. 1.4105/AISI 430FR Springs: Stainless steel, W.no. 1.4310/AISI 301 Seal material: See specific valve data

1) The times are indicative and apply to water. The exact times will depend on the pressure conditions.

Function

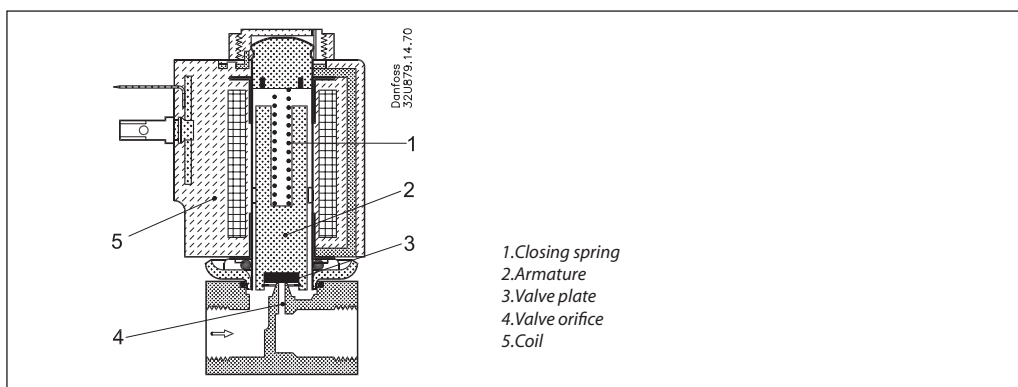

Coil voltage disconnected (closed):
When the voltage to the coil (5) is disconnected, the armature (2) with the valve plate (3) is pressed down against the valve orifice (4) by the closing spring (1) and the medium's pressure. The valve will be closed for as long as the voltage to the coil is disconnected.

Coil voltage connected (open):
When voltage is applied to the coil (5), the armature (2) with the valve plate (3) is lifted clear of the valve orifice (4). The valve is now open for unimpeded flow and will be open for as long as there is voltage to the coil.

Ordering
**EV210B NC versions for AC and DC current:
Stainless steel bodies**

Conn. ISO 228/1	Seal material	k _v value [m ³ /h]	DN [mm]	Media temp		Type designation		Code no. without coil	Permissible differential pressure(bar)/Coil type						
				Min °C	Max. °C	Main type	Specification		BA		BD	BB		BG	
									9W a.c.	15W d.c.	15W a.c.	10W a.c.	18W d.c.	12W a.c.	20W d.c.
G 1/8	EPDM ¹⁾	0.08	1.5	-30	+120	EV210B 1.5SS	G 18 E NC000	032U3645	30	30	30	30	30	30	30
	EPDM ¹⁾	0.15	2.0	-30	+120	EV210B 2.0SS	G 18 E NC000	032U3647	30	20	30	30	30	30	30
	EPDM ¹⁾	0.30	3.0	-30	+120	EV210B 3.0SS	G 18 E NC000	032U3649	15	9	24	20	13	30	25
G 1/4	EPDM ¹⁾	0.15	2.0	-30	+120	EV210B 2.0SS	G 14 E NC000	032U3651	30	20	30	30	30	30	30
	EPDM ¹⁾	0.30	3.0	-30	+120	EV210B 3.0SS	G 14 E NC000	032U3653	15	9	24	20	13	30	25
	EPDM ¹⁾	0.55	4.5	-30	+120	EV210B 4.5SS	G 14 E NC000	032U3655	8.0	3.5	12	10	4.5	13	9

- 1) 140°C / 3.6 bar low pressure steam, orifice DN 1.5 - 4.5.
 - Low pressure steam: DN 1.5 - 3 Use coil type BB or BG.
 DN 4.5 Use coil type BG

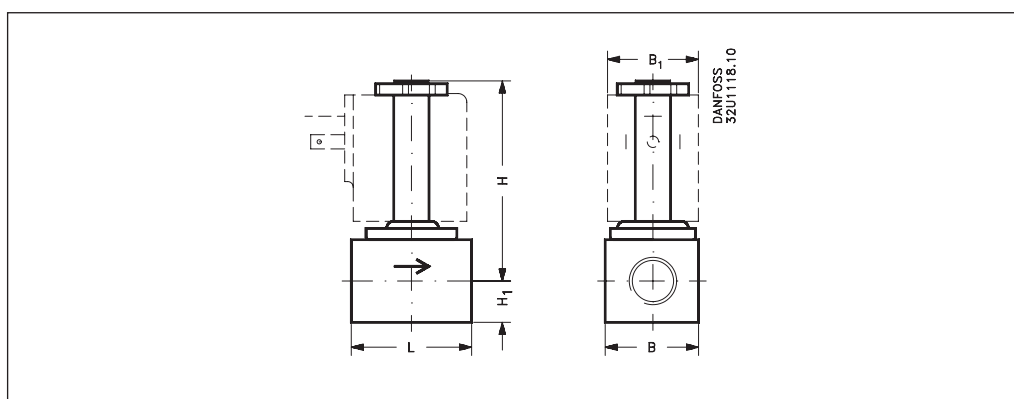
Dimensions and weight

Type	L [mm]	B [mm]	B ₁ [mm]			H ₁ [mm]	H [mm]	Weight without coil [kg]
			Coil type BA/BD	Coil type BB/BE	Coil type BG			
EV210B 1.5/2 SS	35.0	34.0	32	46	66	12.0	70.0	0.15
EV210B 3/4.5 SS	35.0	34.0	32	46	66	11.0	70.0	0.20

Mounting fittings, NC/NO

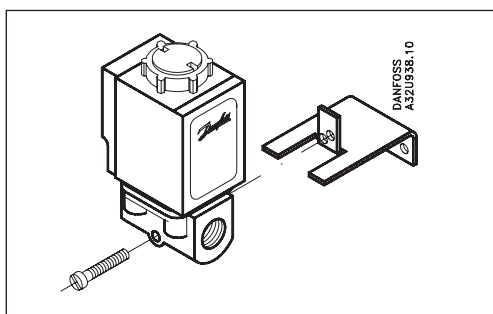

For EV210B 1.5 - 4.5B in connection with synthetic tubes, pipes and similar.

Descrption	Code no.
Brackets	032U1040

Optional Isolating diaphragm kit for EV210B 1.5 - 4.5 NC

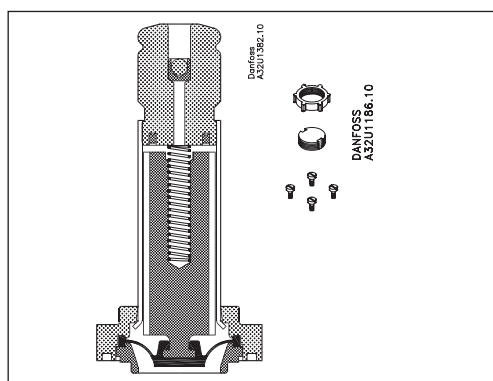

Avoids build up of contaminates that can block movement of the armature. Permits use of more aggressive media that would normally attack the armature. Gel filled; guarentees operation after long perodes on inactivity.

The kit consist of assembled isolating unit, O-ring, 4 screws, locking button and nut for coil. Suitable for orifice sizes up to DN 3 mm.

Seal material	Code no.
EPDM	042U1009
FKM	042U1010

Spare parts kit, NC

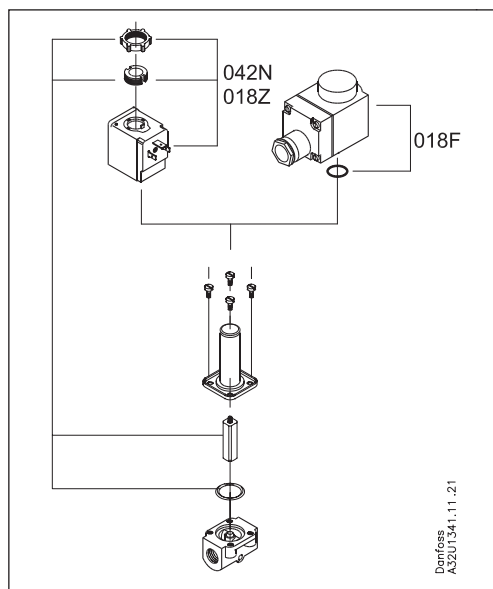

The spare parts kit comprises a locking button, nut for the coil, armature with valve plate and spring, and an O-ring.

Valve type	Seal material	code no.
EV210B 1.5, 2, 3, 4.5	FKM	032U2003
	EPDM	032U6000
EV210B 6, 8, 10	FKM	032U2011
	EPDM	032U2006
EV210B 15	FKM	032U2012
	EPDM	032U2013
EV210B 20	FKM	032U2014
	EPDM	032U2017
EV210B 25	FKM	032U2018
	EPDM	032U2019

Spare parts kit, NO

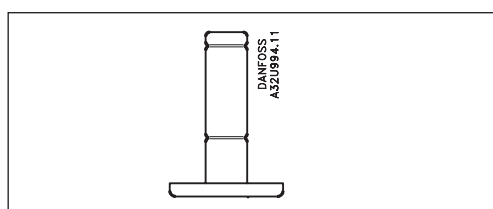

Valve type	Seal material	code no.
EV210B 1.5, 2, 3, 4.5	FKM	032U2004
	EPDM	032U2005

