

Solenoid valves 2/2-way direct-operated Type EV210A

Features

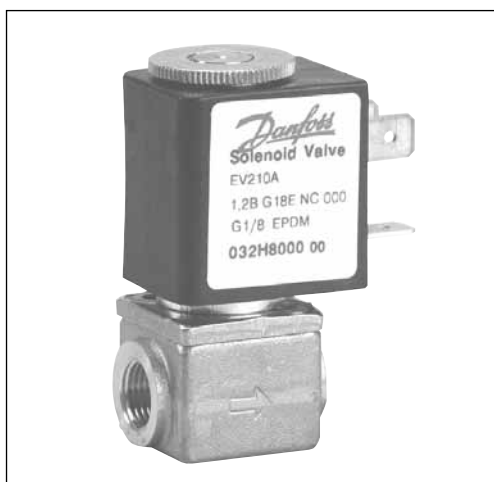

EV210A NC and NO

- Very compact valves for industrial application, such as control and dosage
- For water, oil, compressed air and similar neutral media
- K_v value up to 0.26 m³/h
- Differential pressure: Up to 30 bar
- Viscosity: Up to 20 cSt
- Ambient temperature: Up to +50°C
- Coil enclosure: Up to IP 65
- Thread connections: G 1/8 and G 1/4
- The valves can be used for rough vacuum

Technical data for NC and NO

Installation	Optional, but vertical solenoid system is recommended
Pressure range	0 to 30 bar
Max. test pressure	50 bar
Tightness	Internally: Better than 8.3×10^{-2} mbar l/sec (5 ccm air per min) Externally: Better than 1×10^{-3} mbar l/sec (100% He)
Time to open and close	7 - 10 ms (depending on pressure, coil and viscosity)
Ambient temperature	Max. +50°C
Medium temperature	EPDM: -30 to +120°C FKM: -10 to +100°C
Viscosity	Max. 20 cSt
Materials	Valve body: Brass,..... W.no. 2.0401 Armature: Stainless Steel, W. no. 1.4016/AISI 430 Armature tube: Stainless Steel, W. no. 1.4303/AISI 305 Armature stop: Stainless Steel, W. no. 1.4016/AISI 430 Spring: Stainless Steel, W. no. 1.4310/AISI 301 Valve orifice: Stainless Steel, W. no. 1.4305/AISI 303 O-rings/valve plate: EPDM or FKM

Function NC

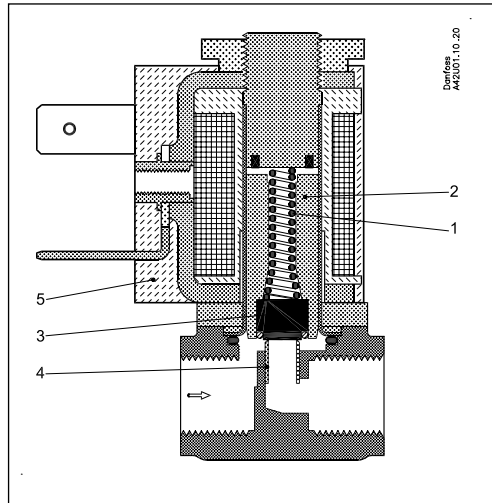

- 1. Closing spring
- 2. Armature
- 3. Valve plate
- 4. Valve orifice
- 5. Coil

Coil voltage disconnected (closed):

When the voltage is disconnected, the armature (2) with the valve plate (3) is pressed down against the valve orifice (4) by the closing spring (1) and the medium's pressure. The valve will be closed for as long as the voltage to the coil is disconnected.

Coil voltage connected (open):

When voltage is applied to the coil (5), the armature (2) with the valve plate (3) is lifted clear of the valve orifice (4).

The valve is now open for unimpeded flow and will be open for as long as there is voltage to the coil.

Dimensions and weight

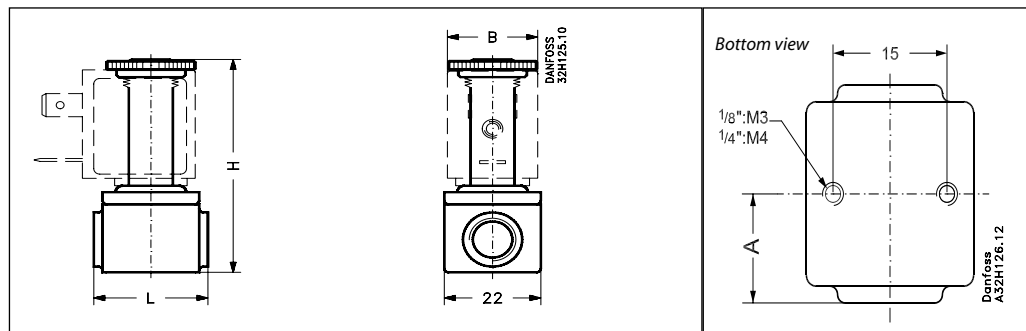

Thread ISO 228/1	L [mm]	B [mm]		H [mm]	A [mm]	Weight with- out coil [kg]
		Coil type AB/ AC	Coil type AM/AK			
G 1/8	26	22	33	54	13	0.085
G 1/4	35	22	33	59	17.5	0.110

Ordering NC valve body

Con- nec- tion ISO 228/1	Seal mate- rial	k _v - Value [m ³ /h]	Ori- fice [mm]	Media temp.		Type designation		Min.	Permissible differential pressure [bar] ²⁾						Suit- able coil type	Code no. without coil
				Min. [°C]	Max. [°C]	Main type	Specification		Max.							
									Water		Oil		Air			
									ac	dc	ac	dc	ac	dc		
G 1/8	EPDM FKM	0.04	1.2	-30+120 -10+100	EV210A 1.2B EV210A 1.2B	G 18E NC000 G 18F NC000	0	30	17.5	28	16	30	19	AB	032H8000¹⁾ 032H8001	
								30	24	30	24	30	24	AC		
								30	24	30	24	30	24	AM		
								-	24	-	24	-	24	AK		
G 1/8	EPDM FKM	0.08	1.5	-30+120 -10+100	EV210A 1.5B EV210A 1.5B	G 18E NC000 G 18F NC000	0	18	9.5	15	8	22	10.5	AB	032H8002¹⁾ 032H8003	
								26	17.5	24	16	30	18.5	AC		
								28	22.5	26	19	30	24	AM		
								-	17.5	-	17.5	-	19	AK		
G 1/8	EPDM FKM	0.11	2.0	-30+120 -10+100	EV210A 2.0B EV210A 2.0B	G 18E NC000 G 18F NC000	0	11	5.5	9	5	14	6	AB	032H8004¹⁾ 032H8005	
								18	10.5	16	9.5	22	11	AC		
								23	18.5	22	17	30	24	AM		
								-	9	-	9	-	9	AK		
G 1/8	EPDM FKM	0.17	2.5	-30+120 -10+100	EV210A 2.5B EV210A 2.5B	G 18E NC000 G 18F NC000	0	6	3	5	2.5	8	3	AB	032H8006¹⁾ 032H8007	
								11	5.5	9	5	12	6	AC		
								17	13	16	12	20	14.5	AM		
								-	5	-	5	-	5	AK		
G 1/8	EPDM FKM	0.22	3.0	-30+120 -10+100	EV210A 3.0B EV210A 3.0B	G 18E NC000 G 18F NC000	0	4	1.5	3	1.5	5	2	AB	032H8008¹⁾ 032H8009	
								7	3.5	6	3	8	3.5	AC		
								13	9	12	8	14	9	AM		
								-	3	-	3	-	3	AK		
G 1/4	EPDM FKM	0.17	2.5	-30+120 -10+100	EV210A 2.5B EV210A 2.5B	G 14E NC000 G 14F NC000	0	6	3	5	2.5	8	3	AB	032H8014¹⁾ 032H8015	
								11	5.5	9	5	12	6	AC		
								17	13	16	12	20	14.5	AM		
								-	5	-	5	-	5	AK		
G 1/4	EPDM FKM	0.22	3.0	-30+120 -10+100	EV210A 3.0B EV210A 3.0B	G 14E NC000 G 14F NC000	0	4	1.5	3	1.5	5	2	AB	032H8016¹⁾ 032H8017	
								7	3.5	6	3	8	3.5	AC		
								13	9	12	8	14	9	AM		
								3	-	3	-	3	-	AK		
G 1/4	EPDM FKM	0.26	3.5	-30+120 -10+100	EV210A 3.5B EV210A 3.5B	G 14E NC000 G 14F NC000	0	2.8	1.2	2	0.8	3.5	1.2	AB	032H8018¹⁾ 032H8019	
								5	2.5	4	2.5	5.5	2.5	AC		
								11	6	10	5.5	11	6	AM		
								-	1.5	-	1.5	-	1.5	AK		

1) WRAS approved

2) Pressure range can be extended for use in rough vacuum, typically up to 99% vacuum (10 mbar), depending on the application

Function NO

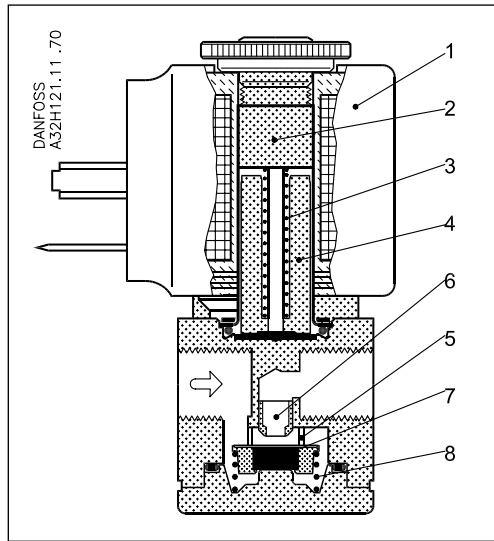

- 1. Coil
- 2. Fixed top
- 3. Opening spring
- 4. Armature
- 5. Pins
- 6. Valve orifice
- 7. Valve plate
- 8. Closing spring

Coil voltage disconnected (open):

When the voltage to the coil is disconnected, the valve orifice (6) is open, the opening spring (3) pressing the valve plate (7) clear of the orifice (6) via the armature (4) and the pins (5). The valve will be open for as long as the supply voltage is disconnected.

Coil voltage connected (closed):

When voltage is applied to the coil, the armature (4) is drawn up to touch the fixed top (2). The valve plate (7) is pressed against the valve orifice (6) by the closing spring (8). The valve will be closed for as long as there is voltage to the coil.



Ordering NO

valve body

Con- nec- tion ISO 228/1	Seal mate- rial ¹⁾	k _v - Value [m ³ /h]	Ori- fice [mm]	Media temp.		Type designation		Permissible differential pressure [bar] ²⁾						Suit- able coil type	Code no. without coil	
				Min. [°C]	Max. [°C]	Main type	Specification	Min.	Max.							
									Water		Oil		Air			
				ac	dc	ac	dc		ac	dc						
G 1/8	FKM	0.06	1.5	-10	+100	EV210A 1.5B	G 18F NO000	0	30	16	24	13	30	16	AM	032H8049
	FKM	0.12	2.0	-10	+100	EV210A 2.0B	G 18F NO000		14	10	11	8	14	10	AM	032H8051
	FKM	0.15	2.5	-10	+100	EV210A 2.5B	G 18F NO000		10	6	8	4.5	10	6	AM	032H8053
	FKM	0.18	3.0	-10	+100	EV210A 3.0B	G 18F NO000		6	4	5	3	6	4	AM	032H8055
	FKM	0.20	3.5	-10	+100	EV210A 3.5B	G 18F NO000		4	3	4	2	4	3	AM	032H8057

1) For WRAS approved seal material in EPDM, please contact Danfoss.

2) Pressure range can be extended for use in rough vacuum, typically up to 99% vacuum (10 mbar), depending on the application

Dimensions and weight

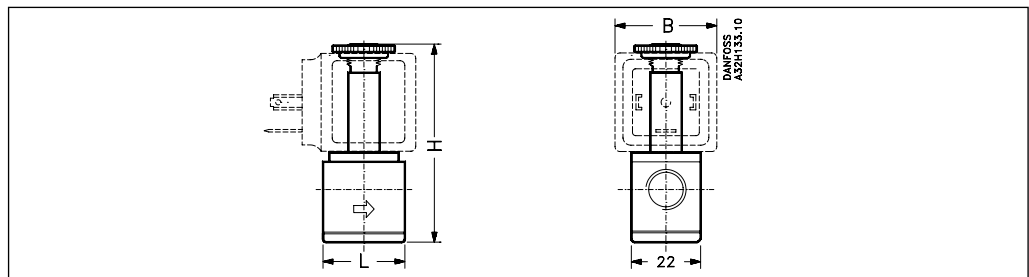

Thread ISO 228/1	L [mm]	B [mm]		H [mm]	Weight without coil [kg]
		Coil type AM			
G 1/8	26	33		63	0.125

Features



EV210A SS

- Very compact valves for industrial application, such as control
- For neutral and aggressive liquids and gases. Contact Danfoss if you are in doubt about the valve's suitability for the medium in question.
- Differential pressure: Up to 30 bar
- Viscosity: Up to 20 cSt
- Ambient temperature: Up to +50°C
- Coil enclosure: Up to IP 65
- Thread connections: G 1/8 and G 1/4
- The valves can be used for rough vacuum

Technical data

Installation	Optional, but vertical solenoid system is recommended
Pressure range	0 to 30 bar
Max. test pressure	50 bar
Tightness	Internally: Better than 8.3×10^{-2} mbar l/sec (5 ccm air per min) Externally: Better than 1×10^{-3} mbar l/sec (100% He)
Time to open and close	7 - 10 ms (depending on pressure, coil and viscosity)
Ambient temperature	Max. +50°C
Medium temperature	FKM: -10 to +100°C
Viscosity	Max. 20 cSt
Materials	Valve body: Stainless Steel, W.no. 1.4305/AISI 303 Armature: Stainless Steel, W. no. 1.4016/AISI 430 Armature tube: Stainless Steel, W. no. 1.4303/AISI 305 Armature stop: Stainless Steel, W. no. 1.4016/AISI 430 Spring: Stainless Steel, W. no. 1.4310/AISI 301 Valve orifice: Stainless Steel, W. no. 1.4305/AISI 303 O-rings/valve plate:FKM

Dimensions and weight

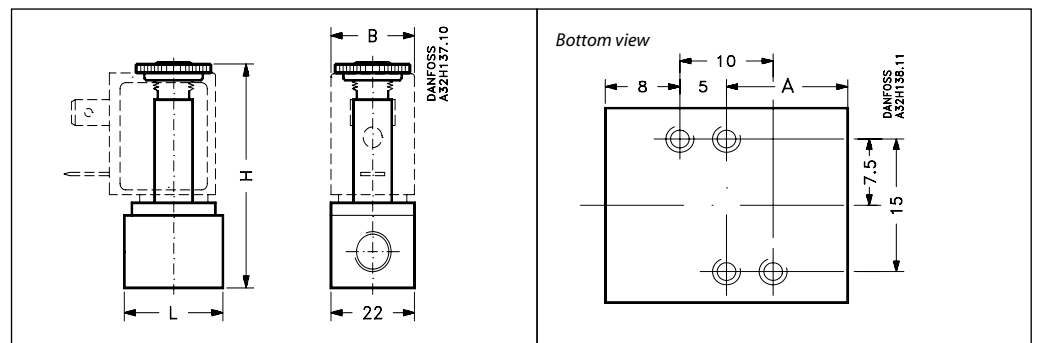

Thread ISO 228/1	L [mm]	B [mm]		H [mm]	A [mm]	Weight with- out coil [kg]
		Coil type AB/ AC	Coil type AM/AK			
G 1/8	26	22	33	54	13	0.085
G 1/4	35	22	33	59	17.5	0.110

Ordering

valve body

Con- nec- tion ISO 228/1	Seal mate- rial ¹⁾	k _v - Value [m ³ /h]	Ori- fice [mm]	Media temp.		Type designation		Min.	Permissible differential pressure [bar] ²⁾						Sui- table coil type	Code no. without coil
				Min. [°C]	Max. [°C]	Main type	Specification		Máx.							
									Water		Oil		Air			
				ac	dc	ac	dc		ac	dc						
G 1/8	FKM	0.04	1.2	-10	+100	EV210A 1.2SS	G 18F NC000	0	30	17.5	28	16	30	19	AB	032H8025
									30	24	30	24	30	24	AC	
									30	24	30	24	30	24	AM	
									-	24	-	24	-	24	AK	
	FKM	0.08	1.5	-10	+100	EV210A 1.2SS	G 18F NC000		18	9.5	15	8	22	10.5	AB	032H8027
									26	17.5	24	16	30	18.5	AC	
									28	22.5	26	19	30	24	AM	
									-	17.5	-	17.5	-	19	AK	
	FKM	0.11	2.0	-10	+100	EV210A 2.0SS	G 18F NC000		11	5.5	9	5	14	6	AB	032H8029
									18	10.5	16	9.5	22	11	AC	
									23	18.5	22	17	30	24	AM	
									-	9	-	9	-	9	AK	
FKM	0.17	2.5	-10	+100	EV210A 2.5SS	G 18F NC000	6	3	5	2.5	8	3	AB	032H8031		
							11	5.5	9	5	12	6	AC			
							17	13	16	12	20	14.5	AM			
							-	5	-	5	-	5	AK			
FKM	0.22	3.0	-10	+100	EV210A 3.0SS	G 18F NC000	4	1.5	3	1.5	5	2	AB	032H8033		
							7	3.5	6	3	8	3.5	AC			
							13	9	12	8	14	9	AM			
							-	3	-	3	-	3	AK			
G 1/4	FKM	0.17	2.5	-10	+100	EV210A 2.5SS	G 14F NC000	6	3	5	2.5	8	3	AB	032H8039	
								11	5.5	9	5	12	6	AC		
								17	13	16	12	20	14.5	AM		
								-	5	-	5	-	5	AK		
	FKM	0.22	3.0	-10	+100	EV210A 3.0SS	G 14F NC000	4	1.5	3	1.5	5	2	AB	032H8041	
								7	3.5	6	3	8	3.5	AC		
								13	9	12	8	14	9	AM		
								-	3	-	3	-	3	AK		
	FKM	0.26	3.5	-10	+100	EV210A 3.5SS	G 14F NC000	2.8	1.2	2	0.8	3.5	1.2	AB	032H8043	
								5	2.5	4	2.5	5.5	2.5	AC		
								11	6	10	5.5	11	6	AM		
								-	1.5	-	1.5	-	1.5	AK		

1) For WRAS approved seal material in EPDM, please contact Danfoss

2) Pressure range can be extended for use in rough vacuum, typically up to 99% vacuum (10 mbar), depending on the application

Coil options

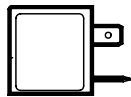

Type AB: 4.5W ac / 5 W dc
Type AC: 7.0 W ac/ 10W dc

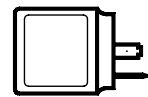

Type AM: 7.5W ac / 9.5 W dc
Type AK: 3.0 W dc

Ordering coils

See separate data sheet for coils DKACV.PD.600.A

Media resistance

Please contact Danfoss

Spare parts

EV210A NC

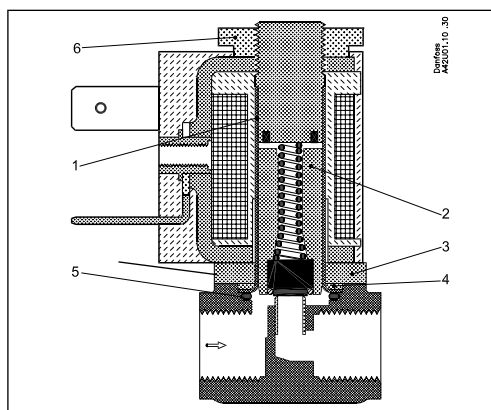

The spare parts set comprises the following parts:

- 1) Armature tube
- 2) Armature with valve plate and spring
- 3) Flange
- 4) Disk
- 5) O-ring
- 6) Nut
- 7) 2 screws for connecting tube to valve body

Seal material	Code No.
EPDM	042U0067
FKM	042U0068