



## Mounting instructions

Rainwater measurement kit



BD SENSORS s.r.o.  
Hradištská 817  
CZ - 687 08 Buchlovice  
Česká republika  
Tel.: +420 572 411 011

## The Rainwater set is intended for monitoring the level in rainwater retention tanks.

### Package contents

- Display unit PA 445
- Hydrostatic probe with cable
- Junction box
- Cabling
- Cable ties
- Screws for mounting the junction box

**WARNING!** When installing this device, the provisions of all relevant legal regulations and technical standards must be observed. Installation of the product and connection to the electrical network according to these instructions may only be performed by a person qualified according to Reg. 50/1978 Sb.

**WARNING** Under no circumstances touch the stainless steel membrane of the probe, there is a risk of irreversible damage.

### Content

- Assembly procedure
- Settings and operation of display unit PA 445
- Maintenance and service
- Spare parts
- Warranty term

#### Quick guide:

#### The device is used to measure the height of the water level.

- 1) Connect the probe cable to the jumper cable in the junction box terminal block.
  - Route all cables into the box.
  - Brown <-> Brown; White <-> Blue; Yellow-green <-> Stripped
  - Leave the tube with the black rubber end loose in the box..
- 2) Connect the connecting cable to the box of display unit PA 445.
  - Route all cables into the box.
  - Blue cable to the X1 clamp and brown to X2 clamp.
  - Stripped wire is not connected in the box.
- 3) Lower the probe to the bottom of the tank (the level above the probe is measured).
- 4) Connect the display unit PA 445 to the mains (230V) – the display shows the level.

## 2. Assembly procedure

### Junction box (black)

Carefully pass the hydrostatic probe cable, including the capillary with the moisture filter, into the junction box (leave the capillary loose in the box) and connect the wires (brown / white) to the terminal block. Twist the remaining cable to a diameter of approx. 30 cm and secure with cable ties so that the lower part of the probe is at a height of approx. 10 cm above the bottom of the tank (reducing the risk of damage to the probe by coarse dirt). Remove the yellow cap from the bottom of the probe. Under no circumstances touch the stainless steel membrane of the probe, there is a risk of irreversible damage.

On the other side, run the connecting cable (20 m) into the junction box. Connect the brown probe wire to the brown jumper wire and the white probe wire to the blue jumper wire at the terminal block. Connect the yellow-green wire of the probe on the terminal board to the shield wire of the connecting cable (thin stripped wire), which ensures resistance to interference of the probe signal. Tighten the cable glands. Close the box with the lid and tighten.

Ideally, place the junction box in the inspection hole (neck) of the retention tank at a height of approx. 40 cm above the maximum water level.

The junction box has a small hole, taped on the inside with a Gore-Tex moisture filter, which ensures that atmospheric pressure is supplied to the inside of the probe. A similar filter is also located at the end of the capillary through the probe cable. Never remove these filters!

### Display unit PA 445

Remove the transparent display cover (Pic. 1/2). Then gently pull on the top electronics board (Pic. 3) and remove the black plastic cover on the bottom board (Pic. 4/5). Route the cable (s) inside the unit through the grommets and connect to the screw terminals inside. Connect the blue wire of the connecting cable (leading the signal from the probe) to terminal X1, the brown wire to terminal X2 (Pic. 6). The shield conductor of the connecting cable is on the display unit PA 445 does not connect.

After connecting the wires, reassemble the entire unit in the reverse order. The upper plate (Pic. 3) to the lower one can be inserted via pin rails mutually rotated by 180°, this allows the device to be mounted with the glands up or the glands down.

Place the PA 445 display unit in a suitable place, ideally indoors and close to a 230 V AC socket. The PA 445 is equipped with a 230 V AC mains cable. Plug the unit's power cord into a household power outlet. This prepares the raincoat set for operation and the display of the electronic unit shows the current water level in the tank in centimeters.

## 2. Settings and operation of display unit PA 445

The display unit PA 445 also allows control of the pump in the tank. With one relay contact, the level of pump shutdown at the minimum level and pump on at the operating level can be controlled (prevents the pump from running dry). For this operating variant, the connection cable to the pump is no longer included in the delivery.

**WARNING!** The connection of the pump control by the electronic unit is subject to inspection by a technician. The following requirements must also be met:

- The selection of cables, installation and electrical connection must comply with the requirements of local regulations that apply to the installation of electrical circuits with a rated voltage up to 1000 V.
- We recommend connecting the device with a nominal value of 30 mA.
- The device is not suitable for installation in places when there is a risk of explosion.
- The switching circuit must be protected to the level of the maximum relay current to prevent the relay output contacts from melting in the event. Of a load short circuit.

### 2.1 Display unit PA 445

The circuits of the PA 445 are located on two printed circuit boards connected via a pin strip. The relay source and control circuits are located on the bottom plate (Fig. 6). On the top board (Fig. 3) are located the control circuits, the display circuits, the input amplifier and the auxiliary supply circuit of the current loop with a current-limiting fuse for one current loop. The bottom plate is mechanically connected to the box. The upper plate to the lower one can be inserted via pin rails in two positions, horizontally or rotated by 180°, this allows the device to be mounted with the glands up or the glands down.

### 2.2 Terminal block on the bottom plate

The clamps are designed as 3 separate structural blocks as follows:

- clamps X1, X2 – input clamps (probe),
- clamps X3, X4 – power supply block (connected at the factory)
- clamps X5 až X10 – block of relay outputs.

**NOTICE!** Sharp objects can scratch and damage the front panel / cover of the unit.  
**NOTICE!** The front panel is not resistant to aggressive alkalis, acids or cleaning with high-pressure cleaners.  
**NOTICE!** Never remove the moisture filters located at the end of the capillary through the probe cable or inside the junction box.

## 2.2.1 Device connection

The switch or circuit breaker must be:

- Part of building installation
- In the immediate vicinity of the equipment
- Achievable by the operator
- Marked as a disconnecting element of the device

**NOTICE:** If the equipment is used in a manner other than that for which it is intended by the manufacturer, the safety provided by the equipment may be impaired.

## 2.2.2 Terminal block connection

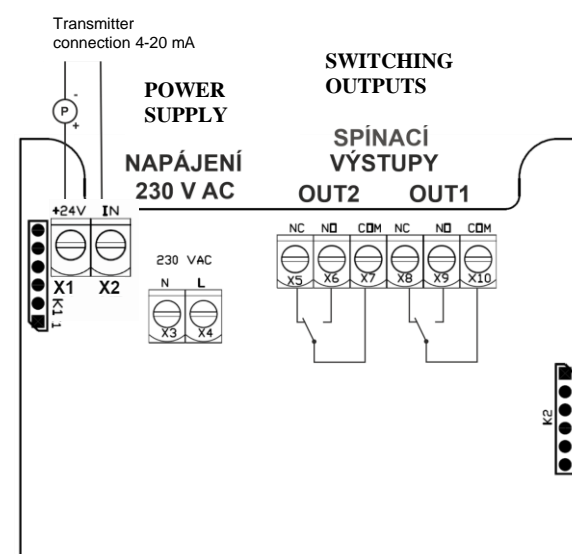

X1 – auxiliary power supply of the probe + 24 V DC  
X2 – input signal of the probe

**NOTICE:** The mains supply terminal block must not be confused with the contact output terminal block or with the auxiliary power supply of the sensor during connection.

**NOTICE:** Danger hazard warning (pay attention to supply voltage).

## 2.3 Input part of display unit PA 445

The 2-wire transducer 4-20 mA/ current signal (0/4 to 20 mA) can be connected to the input terminals of the device. By default, the device is set to the input variable, which is listed in the table of limit values in table 2.9.

## 2.4 Output part of display unit PA 445

The output elements are two miniature relays with a maximum load of 250 VAC, 4 A. When switching inductive loads, it is recommended to connect RC suppressors (eg 0.1 uF + 220 Ω) to the appropriate contacts to increase reliability and reduce interference.

## 2.5 Signalisation

The device is optionally equipped with a signaling function of up to 2 limit values with the possibility of delayed switching on and off of the switching outputs. To switch between the individual modes, it is necessary to change the values at the start point and the off point (Sn1 / SF1). To switch between the individual modes, it is necessary to change the setting in the menu "Mo 1 (optionally Mo 2)" to HY - hysteresis mode or CP - comparison mode. It is also necessary to change the values of the on and off points of the switching output Sn 1 and SF 1 (alternatively Sn 2 and SF 2).

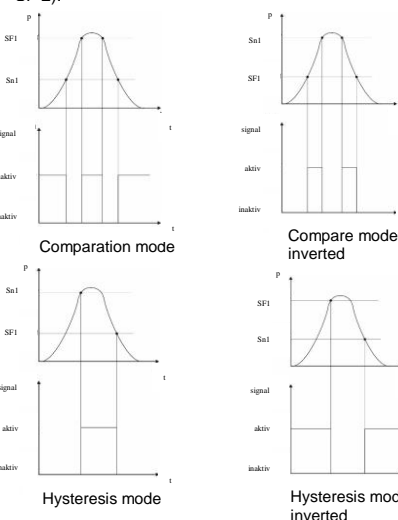

## 2.6 Table of fault conditions

The device is equipped with fault signaling (E). In the event of a sensor failure, relay 1 behaves according to the settings in menu ER1 and relay 2 according to the settings in menu ER2 (more information in chapter "2.8 Meaning of parameters" parameter Er 1, optionally Er 2).

transmitter type	signalisation E ...	signalisation E ...
4 ~ 20 mA	< 3,5 mA	> 21 mA

## 2.7 Programming

Optional device parameters can be set in programming mode. When putting the pointing device into operation, it is necessary to adapt the device to the specific application of the user by setting the required parameters. By default, the factory default values are set in the programming mode, which are listed in the table of parameter limits in table 2.9.

You can change the parameters by entering the menu of the display unit by pressing the MENU key. After entering the menu, the name of the parameter and its value will start flashing alternately, which can be changed with the UP and DOWN keys. To move to the next parameter, press the MENU key. After leaving the program in the END menu with the MENU key, the data will be written.

If no key is pressed for approx. 1 minute during programming, the device automatically goes to the output display without writing the set parameters (TIME OUT function). The display of parameters depends on the hardware configuration of the device.

## 2.8 Parameters meaning

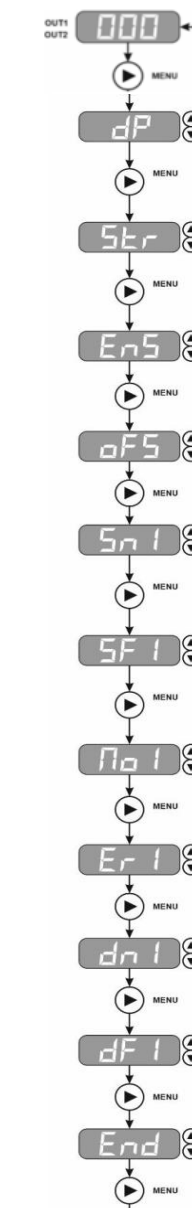

**Operating menu**  
Press the MENU key to enter programming

**dP**  
Decimal point setting

**Str**  
Start of transmitter range

**EnS**  
End of transmitter range

**oFS**  
Transmitter range offset

**Sn1 (optionally Sn2)**  
Setting of the switch on point of the switching outputs

**SF1 (optionally SF2)**  
Setting of the switch off point of the switching outputs

**Mo1 (optionally Mo2)**  
Selection of the compare or hysteresis mode

- **HY** hysteresis mode
- **CP** compare mode

More info in chapter 2.5 Signalisation

**Er1 (optionally Er2)**  
Setting the behavior of the switching outputs in the event of a sensor failure

- **NO** without response to the failure
- **ON** switching contacts turn on
- **OFF** switching contacts turn off

**dn1 (optionally dn2)**  
Setting the switch - on delay of the switching outputs in [s]

**dF1 (optionally dF2)**  
Setting the switch - off delay of the switching outputs in [s]

**End**  
Exit the set menu with save parameters.

**Beware of the TIME OUT function.** With the TIME OUT function, the set parameters are not saved in program mode.

## 2.9 Limit values of parameters

Marking	Meaning	Limit values	From production
dP	Decimal point	0., 0.0, 0.00	0.00
Str	Start of the sensor range	-99 to 999	0.00
End	End of the sensor range	-99 to 999	option 1.00 or 2.00
oFS	Sensor range offset	-99 to 999	0.00
Sn1/Sn2	Output switch on point	-99 to 999	1.00
SF1/SF2	Output switch off point	-99 to 999	0.00
Mo1/Mo2	mode	HY/CP	HY
Er1/Er2	Behavior of outputs in case of failure	_NO/NO/_OFF	OFF
dn1/dn2	Output switch on delay	0 to 100	1
dF1/dF2	Output switch off delay	0 to 100	1

## 3. Maintenance and service

The device is maintenance-free. Warranty and post-warranty service is performed exclusively by BD SENSORS s.r.o. (see Warranty Conditions).

## 4. Spare parts

The design of the device does not require the delivery of spare parts.

## 5. Warranty terms

The manufacturer is responsible for the fact that his product has and will have for a specified period of time the properties specified by technical standards, that it is complete and without defects. The manufacturer is also responsible for defects that the customer finds out during the warranty period and which he complains about in time. The basic condition of the warranty is the use of the pointing device as stated in the user manual.

The warranty period is 24 months from the date of sale.

The warranty can be claimed in the event of material defects or malfunctions of the product. We perform warranty repairs in accordance with the BD SENSORS complaint procedure at the company's registered office.

The warranty expires if modifications have been made to the product and if the product has been damaged by force, mechanical or improper use.

Warranty and post-warranty service is performed exclusively by BD SENSORS.

Pic. 1



Pic. 2



Pic. 3



Pic. 4



Pic. 5

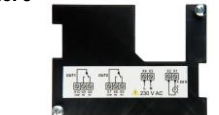

Pic. 6

