

Technical brochure

Pressure controls for air and water, Type CS

MAKING MODERN LIVING POSSIBLE



CS pressure controls have a built-in pressure operated, three-pole switch. The contact position of which depends on the pressure in the connector and the range setting and adjustable differential.

The pressure controls are fitted with a manual switch that will lock the contact system in the open position independently of the pressure in the system. Pressure controls with relief valve is used in compressed air systems where pressure relief on the compressor piston before start is required.

The CS is suited for automatic start and stop of air compressors and water boosters.

Features

- Pressure ranges 2 to 20 bar
- Pressure connection G $\frac{1}{2}$ or G $\frac{1}{4}$
- Contact system 3-pole (TPST) as standard and 1-pole as accessory
- Adjustable differential
- Relief valve as accessory
- Manual switch to lock the contact system
- Enclosure IP 43 or IP 55
- Special versions with pressure connection made of polyacetal suitable in drinking water applications -DWGW (KTW)

Approvals

EN 60 947-4-1
EN 60 947-5-1

China Compulsory Certificate, CCC

Technical data

Specifications

	Contact load a.c.		AC-3	12 A	220 to 415 V	
				9 A	600 V	
			DC-13/14	2 A	220 V	3 contacts in series
	Electrical life on rated load		100.000 operations			
	Mechanical life		1.000.000 operations			
	Ambient temperature		-20 to +70 °C			
	Temperature of medium		Water	0 to +70 °C		
			Air	-20 to +70 °C		
	Vibration-proof		0 - 1000 Hz ved 4 G			
	Resonance frequency		Direction A-B: 341 Hz Direction C-D: 332 Hz Direction E-F: 488 Hz			
Diaphragm material		Hytrell				
Pressure connector		Special: Polyacetal, G $\frac{1}{2}$ Others: Silumin, G $\frac{1}{4}$ or G $\frac{1}{2}$				
Pressure relief valve (capacity)		2000 cm 3 from 10 → 1 bar in 18.8 sec.				
Grade of enclosure to IEC 529		IP 43 or IP 55				

Properties according to EN 60947

Wire dimension	0.7 - 2.5 mm 2
solid/stranded	0.75 - 2.5 mm 2
flexible, with/ without ferrules	0.5 - 1.5 mm 2
flexible, with ferrules	
Tightening torque	max. 1.2 NM
Rated impulse voltage	4 kV
Pollution degree	3
Short circuit protection, fuse	25 Amp
Insulation	600 V
IP-index	43/55

Ordering

Standard pressure switch type CS



Stop pressure p_e bar	Min. differential Δp bar	Max. differential Δp bar	Max. test pressure p_e bar	Grade of enclosure	Pressure connection	Code no.	Type
2 - 6	0.72 - 1.0	1.0 - 2.0	10	IP 43	G $\frac{1}{4}$	031E020266	1-pole
2 - 6	0.72 - 1.0	1.0 - 2.0	10	IP 43	G $\frac{1}{4}$	031E020066	3-pole
2 - 6	0.72 - 1.0	1.0 - 2.0	10	IP 55	G $\frac{1}{4}$	031E020566	
2 - 6	0.72 - 1.0	1.0 - 2.0	10	IP 43	G $\frac{1}{2}$	031E021066	
2 - 6	0.72 - 1.0	1.0 - 2.0	10	IP 55	G $\frac{1}{2}$	031E021566	
4 - 12	1 - 1.5	2.0 - 4.0	20	IP43	G $\frac{1}{4}$	031E022066	
4 - 12	1 - 1.5	2.0 - 4.0	20	IP 55	G $\frac{1}{4}$	031E022566	
4 - 12	1 - 1.5	2.0 - 4.0	20	IP 43	G $\frac{1}{2}$	031E023066	
4 - 12	1 - 1.5	2.0 - 4.0	20	IP 55	G $\frac{1}{2}$	031E023566	
7 - 20	2 - 3.5	3.5 - 7.0	32	IP 43	G $\frac{1}{4}$	031E024066	
7 - 20	2 - 3.5	3.5 - 7.0	32	IP 55	G $\frac{1}{4}$	031E024566	
7 - 20	2 - 3.5	3.5 - 7.0	32	IP 43	G $\frac{1}{2}$	031E025066	
7 - 20	2 - 3.5	3.5 - 7.0	32	IP 55	G $\frac{1}{2}$	031E025566	

Special versions with Polyacetal pressure connection - suitable for drinking water

Stop pressure p_e bar	Min. differential Δp bar	Max. differential Δp bar	Max. test pressure p_e bar	Grade of enclosure	Pressure connection	Code no.	Type
2 - 6	0.72 - 1.0	1.0 - 2.0	10	IP 43	G $\frac{1}{2}$	031E101066	3-pole
4 - 12	1 - 1.5	2.0 - 4.0	20	IP 43	G $\frac{1}{2}$	031E101266	
7 - 20	2 - 3.5	3.5 - 7.0	32	IP 43	G $\frac{1}{2}$	031E101466	

Accessories and spare parts

Description	Code no.
Three pole contact system (TPST)	031E029166
Pressure relief valve, incl. fixing screw (for 6 mm pipe/hose)	031E029866
Pressure relief valve, incl. fixing screw (for 1/4 in. pipe/hose)	031E029766
Two Pg 16 screwed cable entries with gaskets (cable diam. 6.5 - 15 mm)	031E029366
Nipple with 7/16-20 UNF and M10 x 1 int.	031E029666

Design and function

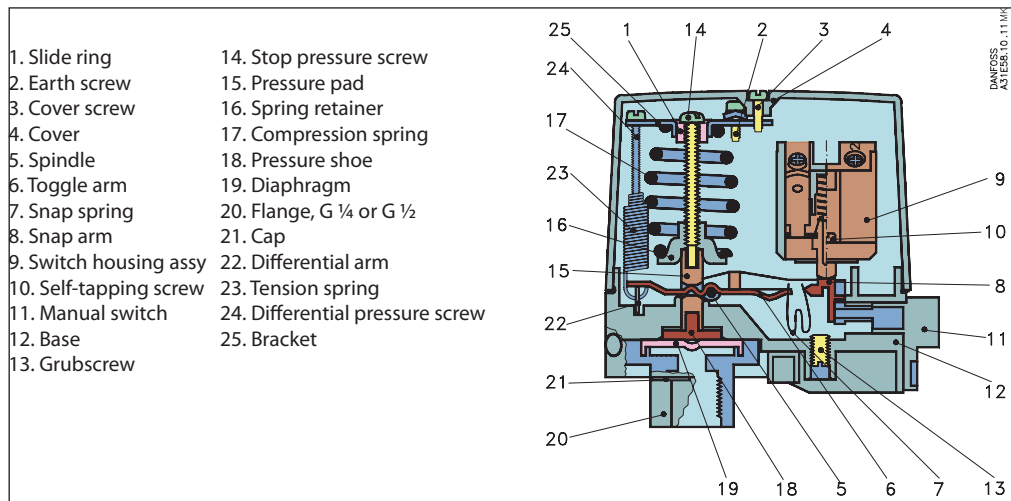

The pressure switch is built up of the following main elements: connector, diaphragm, snap system, main spring, differential spring and a 3-pole or one-pole contact system. The stop pressure must be set on the main spring and the difference between start and stop pressures on the differential spring.

Pressure from the controlled system is led, via the connector, to the diaphragm. The diaphragm converts this pressure to a mechanical movement which is transferred by the snap system to the contact system. In this way, the contact system starts or stops a compressor/pump.

Setting

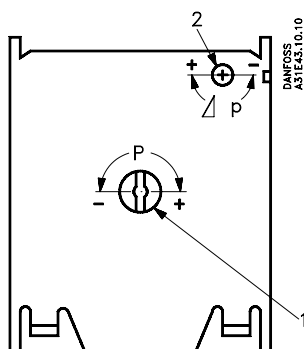

All standard versions of CS pressure switches are preset and supplied with springs under minimum compression.

1. Turn the stop pressure screw (1) the given number of times towards + (high stop pressure), see stop pressure graph.
2. Turn the differential screw (2) the given number of times towards + (max. differential), see differential pressure nomogram.
3. Start the plant and let it run until the required stop pressure is reached.
4. Turn the stop pressure screw (1) towards minus (lower stop pressure) until the plant stops.

5. Reduce the pressure to the required start pressure.
6. Turn the differential screw (2) towards minus (smaller differential) until the plant starts.
7. Check that the plant stops and starts at the required pressures.

Note!
If the differential is set at a value greater than the stop pressure the plant cannot start. If this is the case, set the differential at a smaller value (towards minus).

Example

A compressor is to be regulated by a CS pressure switch. The start pressure is 3.5 bar, and the stop pressure 5 bar. The choice should be a CS with a range of 2 - 6 bar.

1. Turn the stop pressure screw (1) about 12 times. See cut-off pressure graphs.
2. Turn the differential screw (2) about 4.5 times. See CS 2 - 6 nomogram. Take a straight line from 5 bar stop pressure on the nomogram to the differential, 1.5 bar and read off the number of turns, i.e. 4.5.

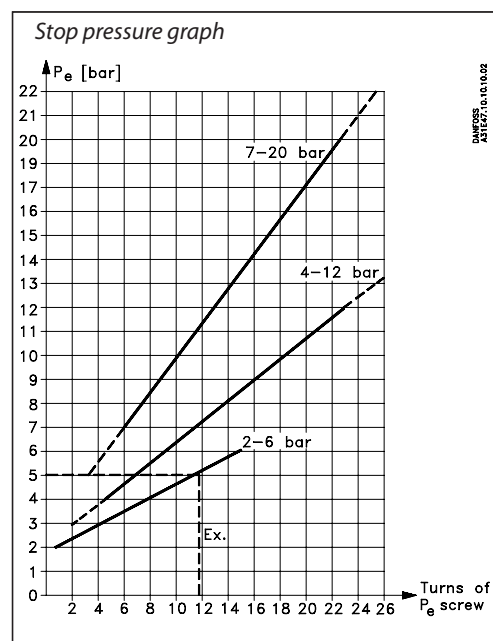

Mains connection

3-pole

1-pole a.c. load

1-pole d.c. load

Contact load		I_e	U_e
		AC-3	12 A
		9 A	600 V
	DC-13/14	2 A	220 V (3 contacts in series)

Dimensions

Weight approx. 0.5 kg

IC.PD.P10.H2.02 / 520B4692

4

Installation

Recommended orientation

The pressure switches will operate regardless of their orientation. However, to meet the enclosure requirements of IP 43 and IP 55, they must be mounted vertically with the connection downwards. The CS pressure switches are self-supporting (on the connection).

Fitting a pressure relief valve

1. Remove the blanking plug
2. Fit the pressure relief valve
3. Fit the plastoform screw

Fitting screwed cable entries

The accessory bag contains two sets of metal gaskets each with different internal diameters. These will give a sufficient cord relief if used correctly with the cable diameter concerned.

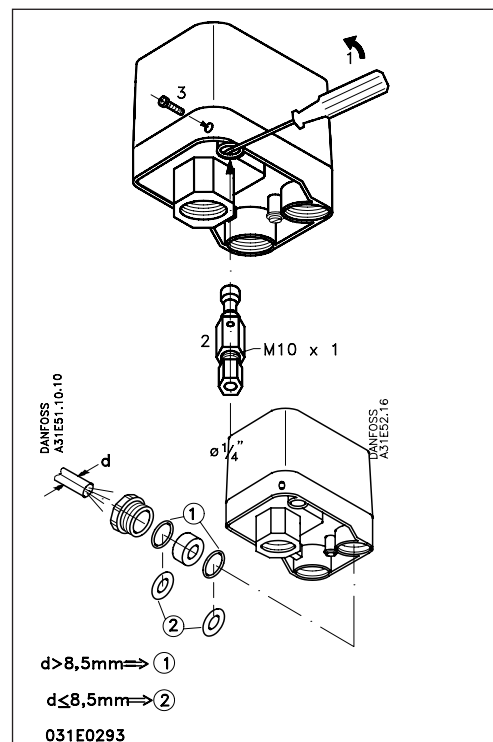

Drain hole

If because of large temperature variations there is a risk of condensate forming in the pressure switch, a screwdriver can be used to make a drain hole in the enclosure.

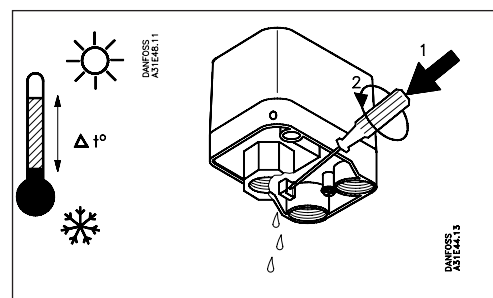

Differential pressure nomograms

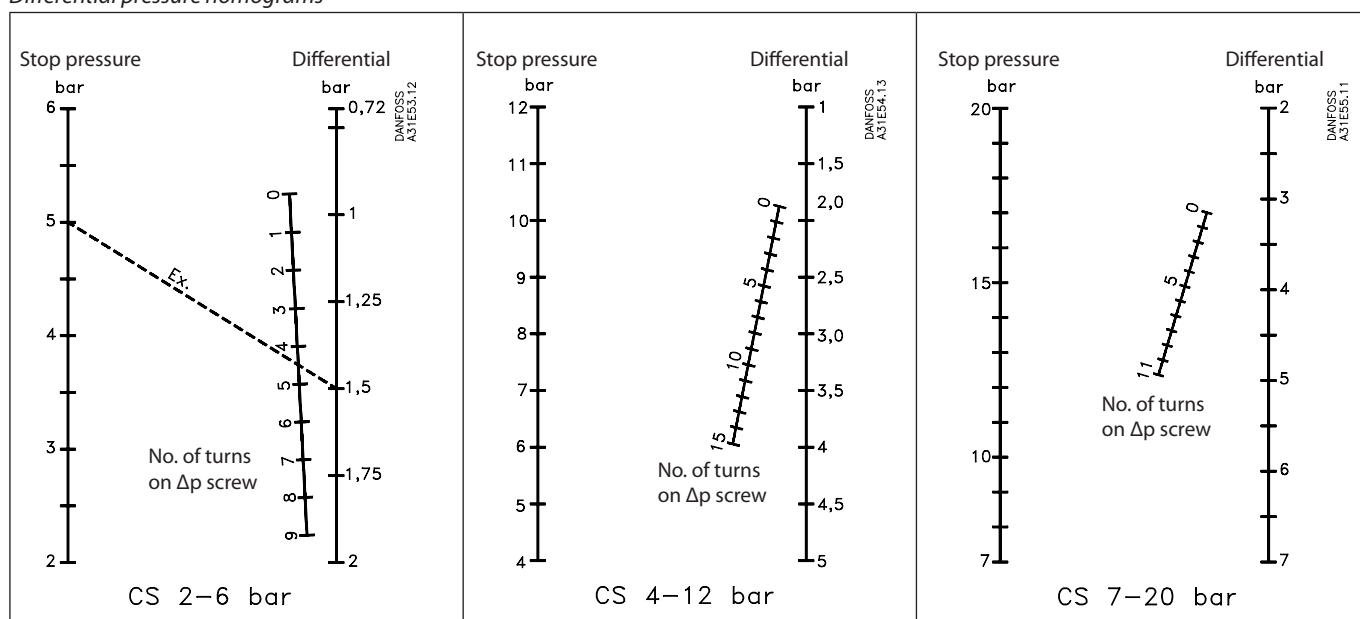

Application examples

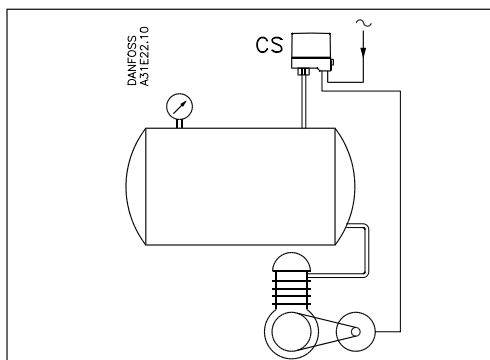

Example 1
Control of an air compressor with a CS pressure switch.

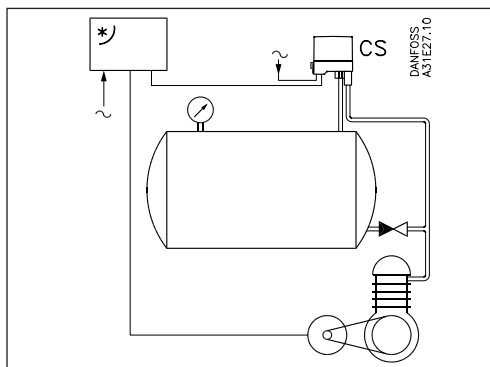

Example 2
Control of a compressor with a CS pressure switch fitted with pressure relief valve. Note the check valve between pressure relief line and reservoir.

* Motor starter or automatic start-delta switch

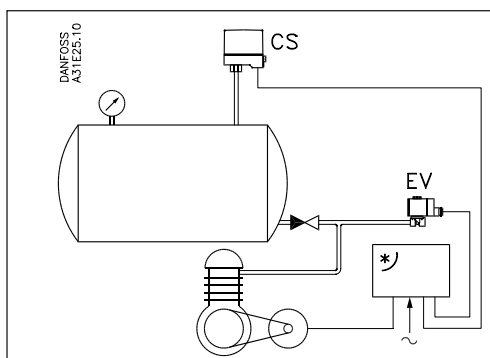

Example 3
Control of an air compressor with a CS. An EV210B 3B solenoid valve is recommended where there is need for especially fast pressure relief.

* Motor starter or automatic start-delta switch

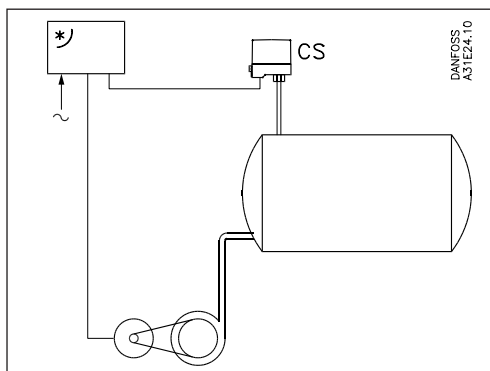

Example 4
Control of a centrifugal pump with a CS, via an automatic star-delta switch, motor starter, or similar.

* Motor starter or automatic start-delta switch

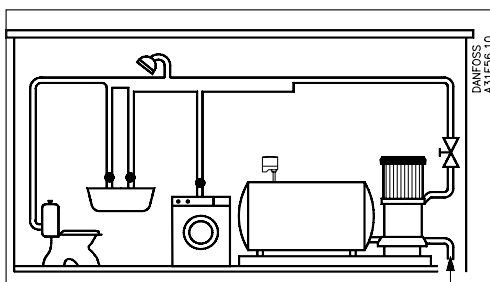

Example 5
Pressure boosting system for domestic circuits. A type CS switch is used to start/stop the pump.

IC.PD.P10.H2.02 / 520B4692