

Foxboro[®] Model 9500A Magnetic Flow Sensor



The 9500A magnetic flow sensor can be used with IMT30A, IMT31A and IMT33A magnetic flow converter.

- ▶ For all water and wastewater applications
- ▶ Wide range of approvals for potable water
- ▶ Robust, fully welded construction

1	Product features	3
<hr/>		
1.1	Reliable solution for the water and wastewater industry	3
1.2	Options	5
1.3	Measuring principle.....	7
2	Technical data	8
<hr/>		
2.1	Technical data.....	8
2.2	Measuring accuracy	14
2.3	Pressure derating.....	15
2.4	Vacuum load	17
2.5	Dimensions and weights	18
3	Installation	22
<hr/>		
3.1	General notes on installation	22
3.1.1	Vibration	22
3.1.2	Magnetic field.....	22
3.2	Installation conditions	23
3.2.1	Inlet and outlet.....	23
3.2.2	Bends in 2 or 3 dimensions.....	23
3.2.3	T-section	24
3.2.4	Bends	24
3.2.5	Open feed or discharge.....	25
3.2.6	Flange deviation	25
3.2.7	Pump	25
3.2.8	Control valve	26
3.2.9	Air venting and vacuum forces	26
3.2.10	Mounting position.....	27
3.3	Mounting.....	27
3.3.1	Torques and pressures.....	27
4	Electrical connections	30
<hr/>		
4.1	Safety instructions.....	30
4.2	Grounding	30
4.3	Virtual reference for IMT33A (C, W and F version)	32
4.4	Connection diagrams	32
5	Model code	33
<hr/>		

1.1 Reliable solution for the water and wastewater industry

The **9500A** is designed to meet the demands for all water and waste water applications including groundwater, potable water, waste water, sludge and sewage, industry water and salt water.

The 9500A has a field proven and unsurpassed lifetime. This is assured by the fully welded construction, full bore pipe, absence of moving parts and wear resistant liner materials. The sensor has the widest diameter range available in the market: from DN25 up to DN2000 (DN3000 available on request).



- ① Robust fully welded construction
- ② Diameter range: DN25...DN3000
- ③ PP, PO and hard rubber liners

Highlights

- Rugged liners suitable for any water and wastewater application
- Proven and unsurpassed lifetime, huge installed base
- Tamper proof, fully welded construction, also available in customer specific constructions
- Drinking water approvals including KTW, KIWA, ACS, DVGW, NSF, WRAS
- Suitable for subsoil installation and constant flooding (IP68)
- Bi-directional flow metering
- Standard in house wet calibration of sensors up to diameter DN3000
- Easy installation and commissioning
- No grounding rings with virtual reference option on IMT33A
- Extensive diagnostic capabilities
- Maintenance-free

Industries

- Water
- Wastewater
- Pulp & Paper
- Minerals & Mining
- Iron, Steel & Metals
- Power

Applications

- Water abstraction
- Water purification and desalination
- Drinking water distribution networks
- Leakage detection
- Irrigation
- Industry water
- Cooling water
- Wastewater
- Sewage and sludge
- Sea water

1.2 Options

The reliable solution for the water and wastewater industry



From standard to customized

For easy ordering the standard range of the 9500A covers all popular sizes, flange materials and connections (ASME, EN, JIS, AWWA).

The 9500A is designed to meet the demands for all water and waste water applications including groundwater, potable water, waste water, sludge and sewage, industry water and salt water.

The 9500A has a field proven and unsurpassed lifetime assured by the fully welded housing, full bore pipe construction, absence of moving parts and wear resistant liner materials.

**Easy installation**

Fitting the 9500A is easy with the flanged design and standard ISO insertion lengths. To further ease the operation, the 9500A can be installed without filters and straighteners. Even grounding rings are not required with the patented **"Virtual Reference"** option on the IMT33A converter.

**IP68**

Installation in measurement chambers subject to (constant) flooding is possible with the IP68 rated version. The chambers can even be completely surpassed if the IP68 version is combined with our special subsoil coating, allowing the 9500A to be installed directly in the ground.

1.3 Measuring principle

An electrically conductive fluid flows inside an electrically insulated pipe through a magnetic field. This magnetic field is generated by a current, flowing through a pair of field coils.

Inside of the fluid, a voltage U is generated:

$$U = v * k * B * D$$

in which:

v = mean flow velocity

k = factor correcting for geometry

B = magnetic field strength

D = inner diameter of flowmeter

The signal voltage U is picked off by electrodes and is proportional to the mean flow velocity v and thus the flow rate q . A signal converter is used to amplify the signal voltage, filter it and convert it into signals for totalizing, recording and output processing.

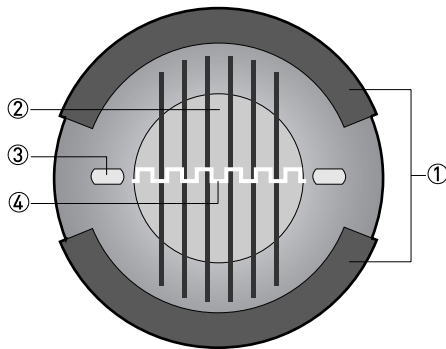

Figure 1-1: Measuring principle

- ① Field coils
- ② Magnetic field
- ③ Electrodes
- ④ Induced voltage (proportional to flow velocity)

2.1 Technical data

- *The following data is provided for general applications. If you require data that is more relevant to your specific application, please contact us or your local sales office.*
- *Additional information (certificates, special tools, software,...) and complete product documentation can be downloaded free of charge from the website.*

Measuring system

Measuring principle	Faraday's law of induction
Application range	Electrically conductive fluids
Measured value	
Primary measured value	Flow velocity
Secondary measured value	Volume flow

Design

Features	Fully welded maintenance-free sensor.
	Large diameter range DN25...2000
	Rugged liners approved for drinking water.
	Large standard range but also available in customer specific diameter, length and pressure rating.
Modular construction	The measurement system consists of a flow sensor and a signal converter. It is available as compact and as separate version. Additional information can be found in the documentation of the signal converter.
Compact version	With signal converter IMT30A
	With signal converter IMT31A
	With signal converter IMT33A
Remote version	In wall (W) mount version with signal converter IMT30A
	In wall (W) mount version with signal converter IMT31A
	In field (F), wall (W) or rack (R) mount version with signal converter IMT33A F, W or R
Nominal diameter	With signal converter IMT30A: DN25...1200 / 1...48"
	With signal converter IMT31A: DN25...1200 / 1...48"
	With signal converter IMT33A: DN25...2000 / 1...80"

Measuring accuracy

Reference conditions	Medium: water
	Temperature: +10...+30°C / +50...+86°F
	Operating pressure: 1 bar / 14.5 psi
	Inlet section ≥ 5 DN
	Electrical conductivity: ≥ 300 µS/cm
Maximum measuring error	IMT30A: 0.5% of the measured value above 0.5 m/s; below 0.5 m/s, deviation ± 2.5 mm/s
	IMT31A: down to 0.3% of the measured value ±1 mm/s
	IMT33A: down to 0.2% of the measured value ±1 mm/s
	The maximum measuring error depends on the installation conditions.
	For detailed information refer to <i>Measuring accuracy</i> on page 14.
Repeatability	±0.1% of the measured value, minimum 1 mm/s
Calibration / Verification	Standard:
	2 point calibration by a direct volume comparison.
	Only in combination with the signal converter IMT33A.

Operating conditions

Temperature	
For detailed information in pressure / temperature refer to <i>Pressure derating</i> on page 15.	
	For Ex versions different temperatures are valid. Please refer to the relevant Ex documentation for details.
Process temperature	Hard rubber liner: -5...+80°C / +23...+176°F
	Polypropylene liner: -5...+90°C / +23...+194°F
	Polyolefin liner: -5...+80°C / +23...+176°F
Ambient temperature	Standard (with aluminum signal converter housing): standard flanges
	-20...+65°C / -4...+149°F
	Option (with aluminum signal converter housing): low temperature carbon steel flanges or stainless steel flanges
	-40...+65°C / -40...+149°F
	Option (with stainless steel signal converter housing): low temperature carbon steel flanges or stainless steel flanges
	-40...+55°C / -40...+130°F
Protect electronics against self-heating at ambient temperatures above +55°C / +131°F.	
Storage temperature	-50...+70°C / -58...+158°F
Measuring range	-12...+12 m/s / -40...+40 ft/s
Pressure	
For detailed information in pressure / temperature refer to <i>Pressure derating</i> on page 15.	

EN 1092-1	DN1200...2000: PN6
	DN200...1000: PN10
	DN65 and DN100...150: PN16
	DN25...50 and DN80: PN40
ASME B16.5	1...24": 150 & 300 lb RF
JIS	DN50...1000 / 2...40": 10 K
	DN25...40 / 1...1½": 20 K
AWWA (class B or D FF)	Option:
	DN700...1000 / 28...40": ≤ 10 bar / 145 psi
	DN1200...2000 / 48...80": ≤ 6 bar / 87 psi
DIN	PN16 - 6 bar rated; DN700...2000
	PN10 - 6 bar rated; DN700...2000
	PN6 - 2 bar rated; DN700...2000
Vacuum load	For detailed information refer to <i>Vacuum load</i> on page 17.
Pressure loss	Negligible
Chemical properties	
Physical condition	Electrically conductive liquids
Electrical conductivity	Standard: ≥ 5 μS/cm
	Demineralised water: ≥ 20 μS/cm
Permissible gas content (volume)	IMT30A: ≤ 3%
	IMT31A: ≤ 3%
	IMT33A: ≤ 5%
Permissible solid content (volume)	IMT30A: ≤ 10%
	IMT31A: ≤ 10%
	IMT33A: ≤ 70%

Installation conditions

Installation	Assure that the flow sensor is always fully filled.
	For detailed information refer to <i>Installation</i> on page 22.
Flow direction	Forward and reverse
	Arrow on flow sensor indicates flow direction.
Inlet run	≥ 5 DN
Outlet run	≥ 2 DN
Dimensions and weights	For detailed information refer to <i>Dimensions and weights</i> on page 18.

Materials

Flow sensor housing	Sheet steel
Measuring tube	Austenitic stainless steel
Flanges	Carbon steel
Liner	Standard:
	DN25...150 / 1...6": polypropylene
	DN200...2000 / 8...80": hard rubber
	Option:
	DN25...150 / 1...6": hard rubber DN200...1000 / 8...40": polyolefin
Protective coating	On exterior of the meter: flanges, housing, signal converter (compact version) and / or connection box (field version)
	Standard: polyurethane coating
	Option: subsoil coating, offshore coating
Connection box	Only for remote versions
	Standard: die-cast aluminum
	Option: stainless steel
Measuring electrodes	Standard: Hastelloy® C
	Option: stainless steel, titanium
Grounding rings	Standard: stainless steel
	Option: Hastelloy® C, titanium, tantalum
	Grounding rings can be omitted with virtual reference option for the signal converter IMT33A.
Reference electrode (optional)	Standard: Hastelloy® C
	Option: stainless steel, titanium

Process connections

Flange	
EN 1092-1	DN25...3000 in PN2.5...40
ASME	1...24" in 150 & 300 lb RF
JIS	DN25...1000 in 10...20 K
AWWA	DN700...2000 in 6...10 bar
Design of gasket surface	RF

Electrical connections

	For full detail refer to the relevant documentation of the signal converter.
Signal cable (remote versions only)	
Type A (DS)	In combination with the signal converter IMT30A, IMT31A and IMT33A Standard cable, double shielded. Max. length: 600 m / 1968 ft (depends on electrical conductivity and flow sensor)
Type B (BTS)	Only in combination with the signal converter IMT33A Optional cable, triple shielded. Max. length: 600 m / 1968 ft (depends on electrical conductivity and flow sensor)
I/O	For full details of I/O options, including data streams and protocols, see technical datasheet of the relevant signal converter.

Approvals and certificates

CE	
This device fulfils the statutory requirements of the EU directives. The manufacturer certifies successful testing of the product by applying the CE mark.	
	For full information of the EU directive & standards and the approved certifications; see the CE declaration or the manufacturer website.
Hazardous area	
ATEX	Please check the relevant Ex documentation for details.
	Compact version with signal converter IMT31A
	II 2 GD
	Compact version with signal converter IMT33A
	II 2 GD or II 2(1) GD
	Remote version
	II 2 GD
FM	In combination with signal converter IMT33A
	Class I, Div. 2, Groups A, B, C and D
	Class II, Div. 2, Groups F and G
	Class III, Div. 2, Groups F and G
CSA	In combination with signal converter IMT33A
	Class I, Div. 2, Groups A, B, C and D
	Class II, Div. 2, Groups F and G
Other approvals and standards	
Drinking water approvals	Hard rubber liner: NSF / ANSI standard 61 / ACS, KTW(<60°C), DVGW-W270, KIWA on request.
	Polypropylene liner: ACS, KIWA/ATA, KTW, NSF / ANSI standard 61, DVGW-W270, WRAS
	Polyolefin liner: ACS, KIWA/ATA, KTW, DVGW-W270, WRAS
Protection category acc. to IEC 529 / EN 60529	Standard:
	IP66 / 67 (NEMA 4/4X/6)
	Option:
	IP68 (NEMA 6P) IP68 is only available for separate design and with a stainless steel connection box.
Shock test	IEC 68-2-27
	30 g for 18 ms
Vibration test	IEC 68-2-64
	f = 20-2000 Hz, rms = 4.5 g, t = 30 min

2.2 Measuring accuracy

Each flowmeter is standard wet calibrated under reference conditions by direct volume comparison. The performance of the flowmeter is defined and documented in an individual calibration certificate.

Reference conditions

- Medium: water
- Temperature: +10...+30°C / +50...+86°F
- Operating pressure: 1 bar / 14.5 psi
- Inlet section: ≥ 5 DN
- Electrical conductivity: $\geq 300 \mu\text{S/cm}$

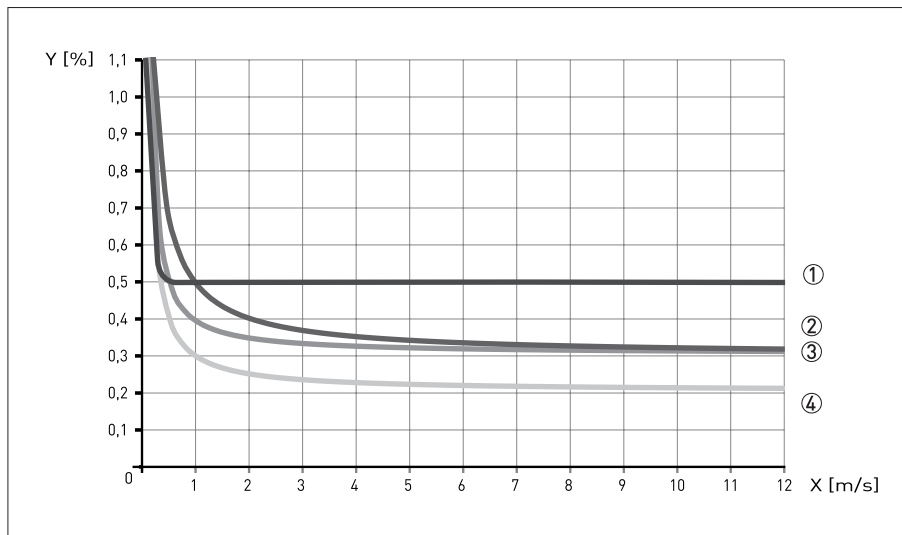

Figure 2-1: Flow velocity vs. accuracy
 X [m/s] : flow velocity
 Y [%]: deviation from the actual measured value (mv)

Accuracy

Flow sensor diameter	Signal converter type	Accuracy	Curve
DN25...1200 / 1...48"	IMT30A	0.5% of mv above 0,5 m/s, below 0,5 m/s, deviation ± 2.5 mm/s	①
DN25...1200 / 1...48"	IMT31A	0.3% of mv + 1 mm/s	③
DN25...1600 / 1...64"	IMT33A	0.2% of mv + 1 mm/s	④
DN1800...2000 / > 64"	IMT33A	0.3% of mv + 2 mm/s	②

2.3 Pressure derating

The graphs below refer to the maximum pressure as a function of the temperature for the flanges of the flowmeter (per specified flange material).

Please note that the specified values only refer to the flanges. The maximum value for the flowmeter can further be limited by the maximum value for other materials (o.a. the liner)

For A = Carbon steel A 105 & B = Stainless steel 316L

X/Y axes in all graphs; X = Temperature in [°C] / Y = Pressure in [bar]

x/y axes in all graphs; x = Temperature in [°F] / y = Pressure in [psi]

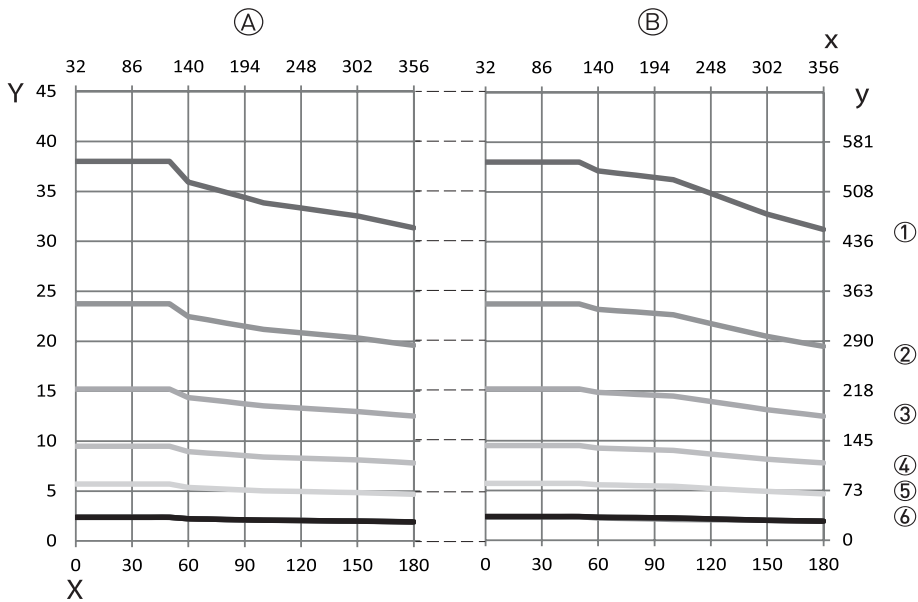

Figure 2-2: Pressure derating; EN 1092-1

- ① PN 40
- ② PN 25
- ③ PN 16
- ④ PN 10
- ⑤ PN 6
- ⑥ PN 2.5

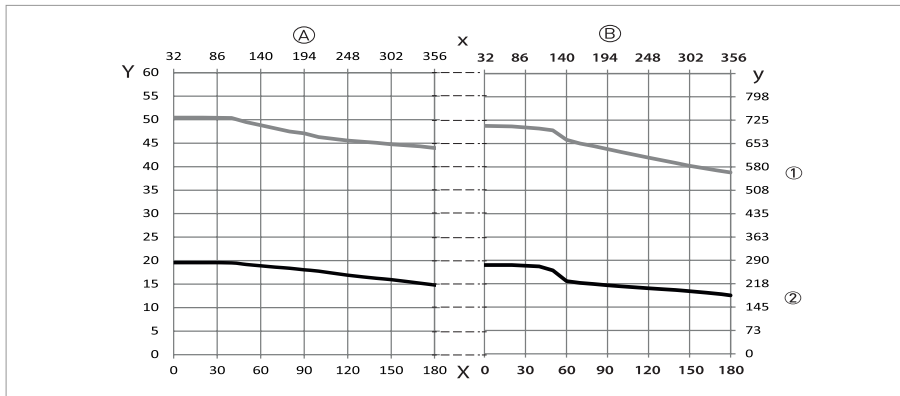

Figure 2-3: Pressure derating; ANSI B16.5

- ① 300 lbs
- ② 150 lbs

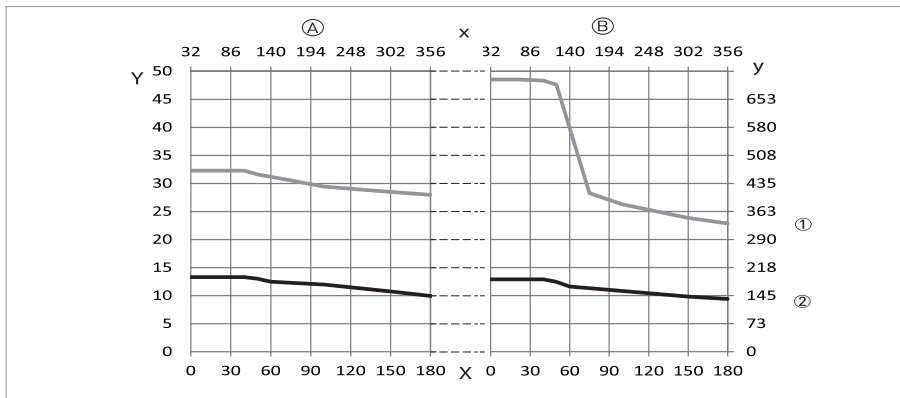

Figure 2-4: Pressure derating; JIS B2220

- ① 20K
- ② 10K

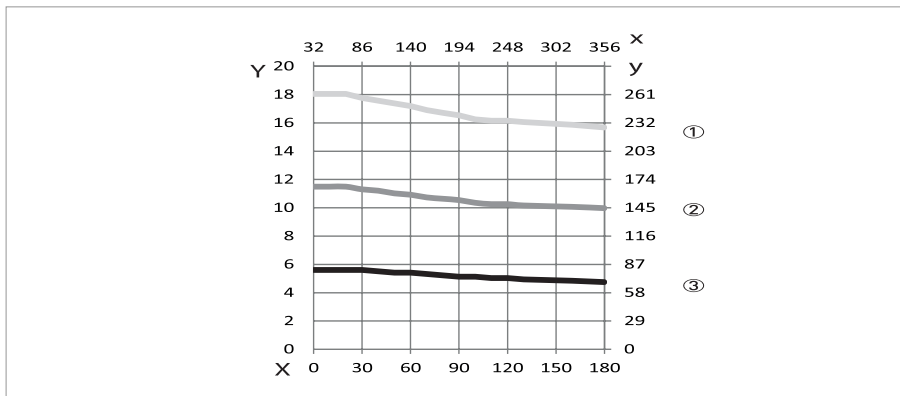

Figure 2-5: Pressure derating; AWWA C207

- ① Class D2 [$>12''$]
- ② Class D1 [4...12"]
- ③ Class B

2.4 Vacuum load

Diameter	Vacuum load in mbar abs. at a process temperature of			
[mm]	20°C	40°C	60°C	80°C
Hard rubber				
DN200...300	250	250	400	400
DN350...1000	500	500	600	600
DN1200...2000	600	600	750	750
Polypropylene				
DN25...150	250	250	400	400
Polyolefin				
DN200...1000	0	0	0	0

Diameter	Vacuum load in psia at process temperature of			
[inch]	68°F	104°F	140°F	176°F
Hard rubber				
8...12	3.6	3.6	5.8	5.8
14...40	7.3	7.3	8.7	8.7
48...80	8.7	8.7	10.9	10.9
Polypropylene				
1...6	3.6	3.6	5.8	5.8
Polyolefin				
8...40	0	0	0	0

2.5 Dimensions and weights

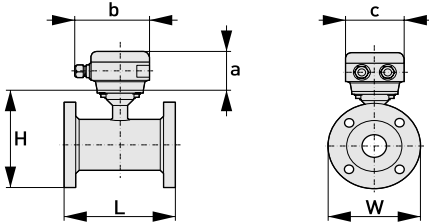
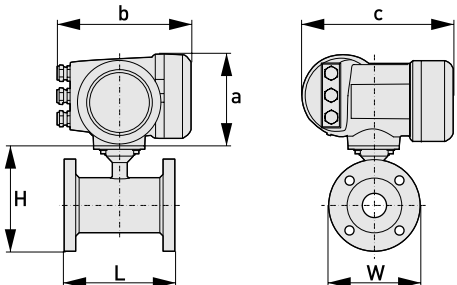
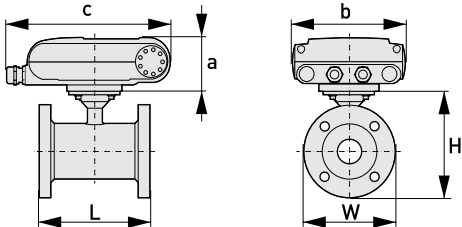
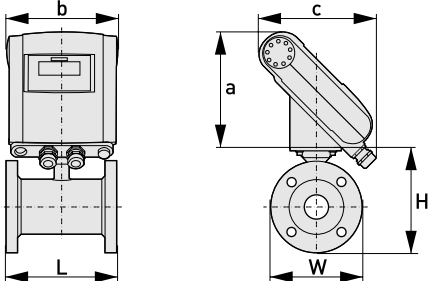
<p>Remote version</p>		<p>a = 88 mm / 3.5"</p> <p>b = 139 mm / 5.5" ①</p> <p>c = 106 mm / 4.2"</p> <p>Total height = H + a</p>
<p>Compact version with : IMT33A</p>		<p>a = 155 mm / 6.1"</p> <p>b = 230 mm / 9.1" ①</p> <p>c = 260 mm / 10.2"</p> <p>Total height = H + a</p>
<p>Compact version with: IMT31A (0°)</p>		<p>a = 82 mm / 3.2"</p> <p>b = 161 mm / 6.3"</p> <p>c = 257 mm / 10.1" ①</p> <p>Total height = H + a</p>
<p>Compact version with: IMT31A (45°)</p>		<p>a = 186 mm / 7.3"</p> <p>b = 161 mm / 6.3"</p> <p>c = 184 mm / 7.3" ①</p> <p>Total height = H + a</p>

<p>Compact version with: IMT30A (10°)</p>		<p>a = 101 mm / 3.98" b = 157 mm / 6.18" c = 260 mm / 10.24" ① Total height = H + a</p>
---	--	--

① The value may vary depending on the used cable glands.

- All data given in the following tables are based on standard versions of the flow sensor only.
- Especially for smaller nominal sizes of the flow sensor, the signal converter can be bigger than the flow sensor.
- Note that for other pressure ratings than mentioned, the dimensions may be different.
- For full information on signal converter dimensions see relevant documentation.

EN 1092-1

Nominal size DN [mm]	Dimensions [mm]				Approx. weight [kg]
	Standard length	ISO Insertion length	H	W	
25	150	200	140	115	5
32	150	200	157	140	6
40	150	200	166	150	7
50	200	200	186	165	11
65	200	200	200	185	9
80	200	200	209	200	14
100	250	250	237	220	15
125	250	250	266	250	19
150	300	300	300	285	27
200	350	350	361	340	34
250	400	450	408	395	48
300	500	500	458	445	58
350	500	550	510	505	78
400	600	600	568	565	101
450	600	-	618	615	111
500	600	-	671	670	130
600	600	-	781	780	165
700	700	-	898	895	248
800	800	-	1012	1015	331
900	900	-	1114	1115	430
1000	1000	-	1225	1230	507
1200	1200	-	1417	1405	555
1400	1400	-	1619	1630	765
1600	1600	-	1819	1830	1035
1800	1800	-	2027	2045	1470
2000	2000	-	2259	2265	1860

ASME B16.5 / 150 lb flanges

Nominal size [inch]	Dimensions [inch]			Approx. weight [lb]
	L	H	W	
1"	5.91	5.39	4.25	7
1½"	5.91	6.10	5.00	11
2"	7.87	7.05	5.98	18
3"	7.87	8.03	7.50	26
4"	9.84	9.49	9.00	44
5"	9.84	10.55	10.00	49
6"	11.81	11.69	11.00	64
8"	13.78	14.25	13.50	95
10"	15.75	16.30	16.00	143
12"	19.69	18.78	19.00	207
14"	27.56	20.67	21.00	284
16"	31.50	22.95	23.50	364
18"	31.50	24.72	25.00	410
20"	31.50	26.97	27.50	492
24"	31.50	31.38	32.00	675

ASME B16.5 / 300 lb flanges

Nominal size [inch]	Dimensions [inch]			Approx. weight [lb]
	L	H	W	
1"	5.91	5.71	4.87	11
1½"	7.87	6.65	6.13	13
2"	9.84	7.32	6.50	22
3"	9.84	8.43	8.25	31
4"	11.81	10.00	10.00	44
6"	12.60	12.44	12.50	73
8"	15.75	15.04	15.00	157
10"	19.69	17.05	17.50	247
12"	23.62	20.00	20.50	375
14"	27.56	21.65	23.00	474
16"	31.50	23.98	25.50	639
20"	31.50	28.46	30.50	937
24"	31.50	33.39	36.00	1345

Responsibility for the use of the measuring devices with regard to suitability, intended use and corrosion resistance of the used materials against the measured fluid lies solely with the operator.

The manufacturer is not liable for any damage resulting from improper use or use for other than the intended purpose.

The 9500A electromagnetic flowmeter is designed exclusively to measure the flow of electrically conductive, liquid media.

3.1 General notes on installation

Inspect the packaging carefully for damages or signs of rough handling. Report damage to the carrier and to the local office of the manufacturer.

Do a check of the packing list to make sure that you have all the elements given in the order.

Look at the device nameplate to ensure that the device is delivered according to your order. Check for the correct supply voltage printed on the nameplate.

3.1.1 Vibration

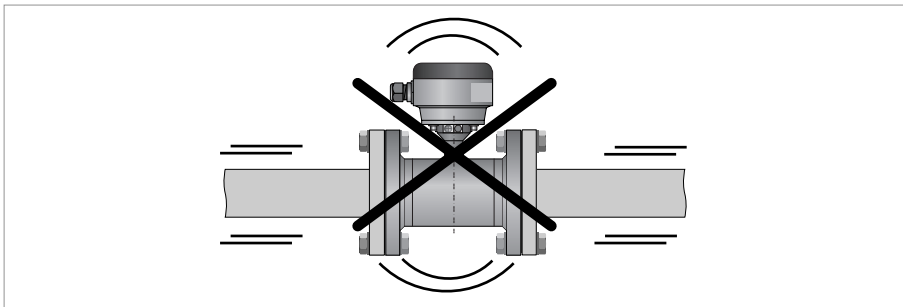

Figure 3-1: Avoid vibrations

3.1.2 Magnetic field

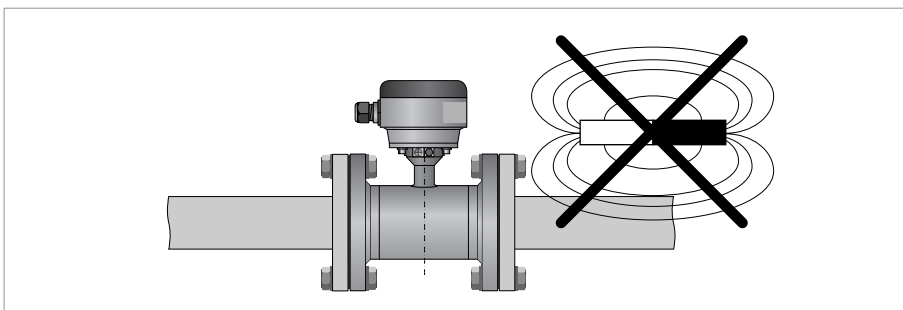

Figure 3-2: Avoid magnetic fields

3.2 Installation conditions

3.2.1 Inlet and outlet

Use straight inlet and outlet pipe sections to prevent flow distortion or swirl, caused by bends and T- sections.

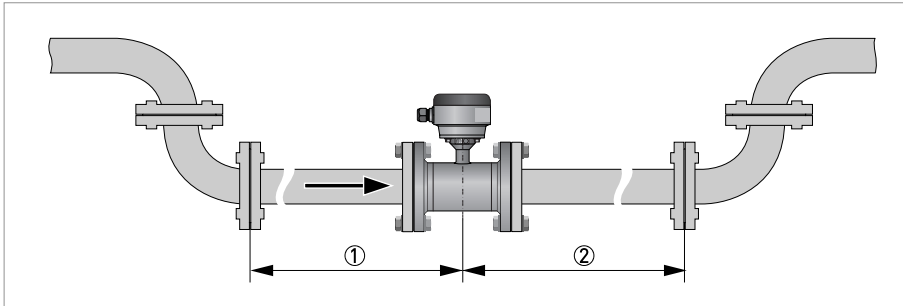

Figure 3-3: Recommended inlet and outlet section

- ① Refer to chapter "Bends in 2 or 3 dimensions"
- ② ≥ 2 DN

3.2.2 Bends in 2 or 3 dimensions

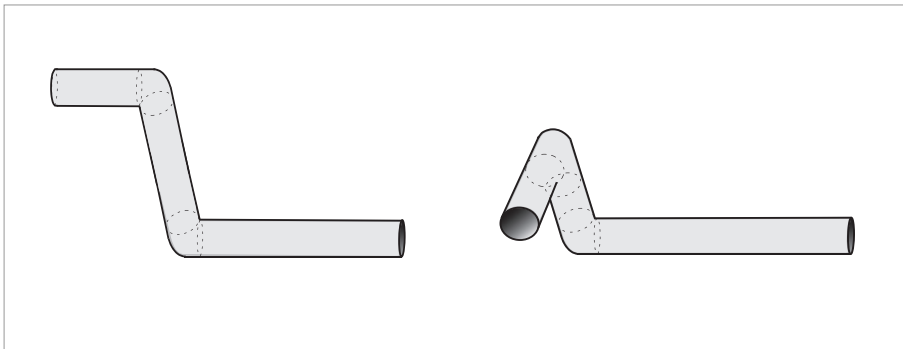

Figure 3-4: Inlet when using 2 and/or 3 dimensional bends in front of the flowmeter

Inlet length: using bends in 2 dimensions: ≥ 5 DN; when having bends in 3 dimensions: ≥ 10 DN

3.2.3 T-section

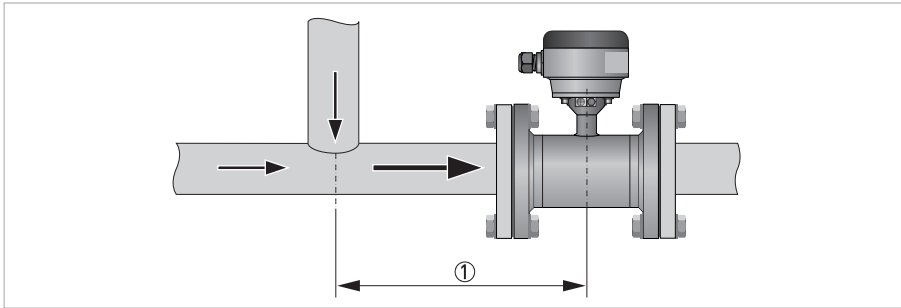

Figure 3-5: Distance behind a T-section

① ≥ 10 DN

3.2.4 Bends

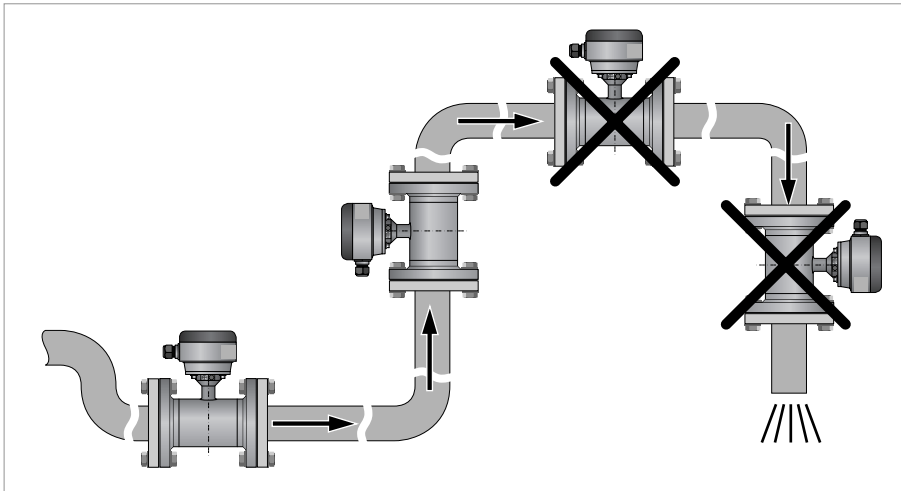

Figure 3-6: Installation in bending pipes

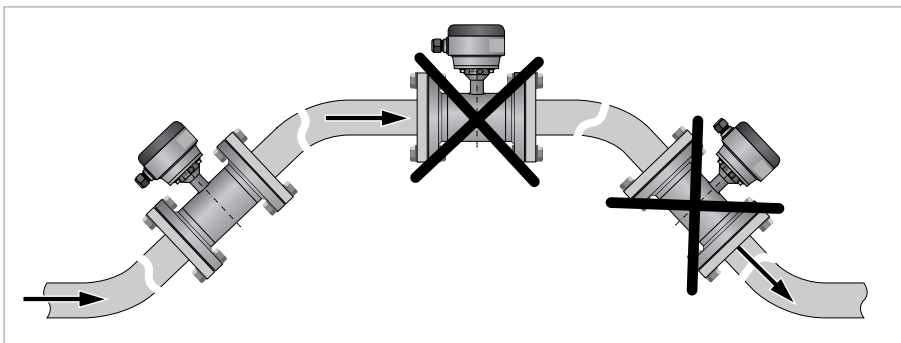

Figure 3-7: Installation in bending pipes

Avoid draining or partial filling of the flow sensor

3.2.5 Open feed or discharge

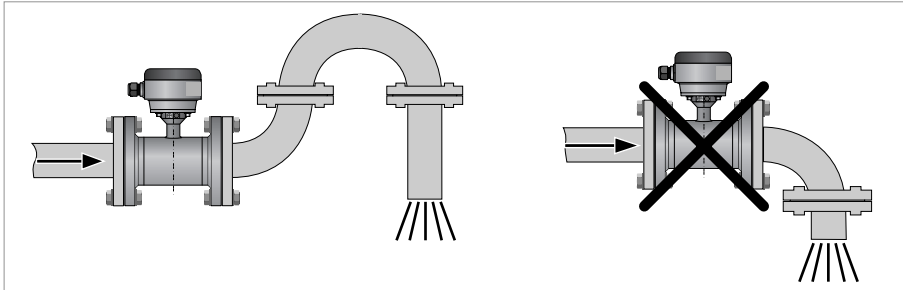

Figure 3-8: Installation in front of an open discharge

3.2.6 Flange deviation

Max. permissible deviation of pipe flange faces:
 $L_{max} - L_{min} \leq 0.5 \text{ mm} / 0.02''$

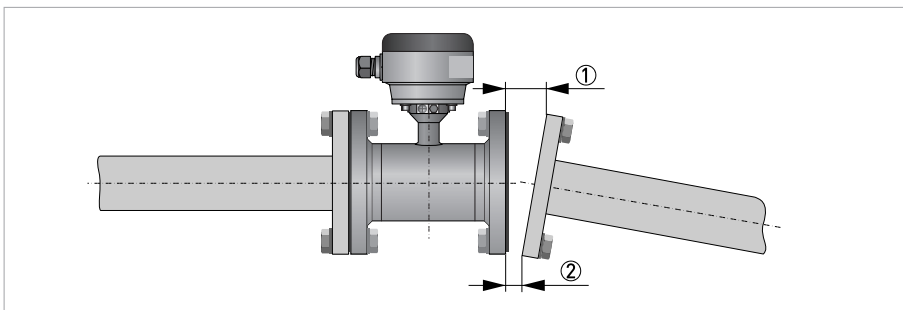

Figure 3-9: Flange deviation

- ① L_{max}
- ② L_{min}

3.2.7 Pump

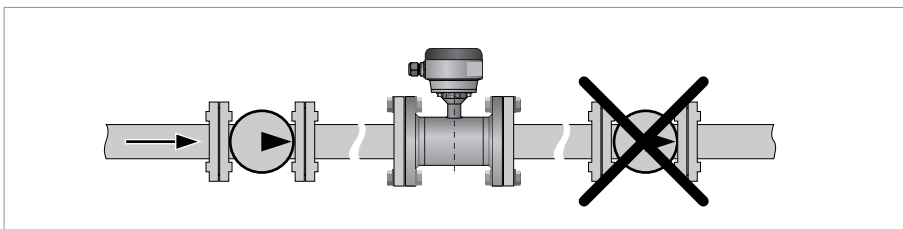

Figure 3-10: Installation behind a pump

3.2.8 Control valve

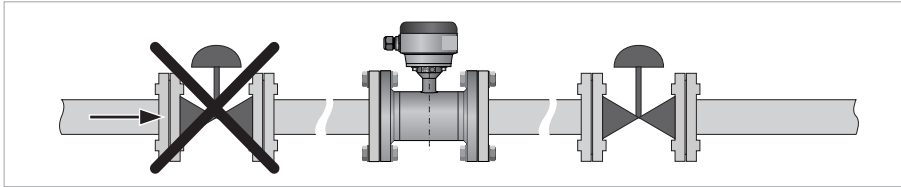

Figure 3-11: Installation in front of a control valve

3.2.9 Air venting and vacuum forces

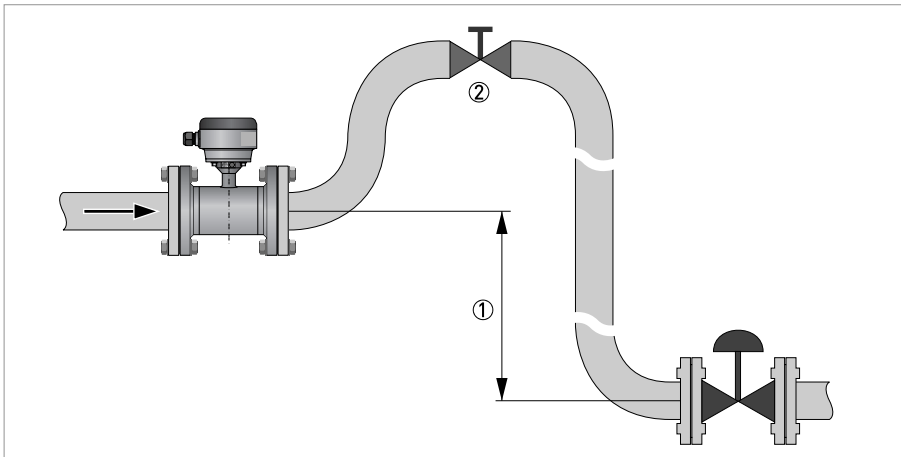

Figure 3-12: Air venting

- ① ≥ 5 m
- ② Air ventilation point

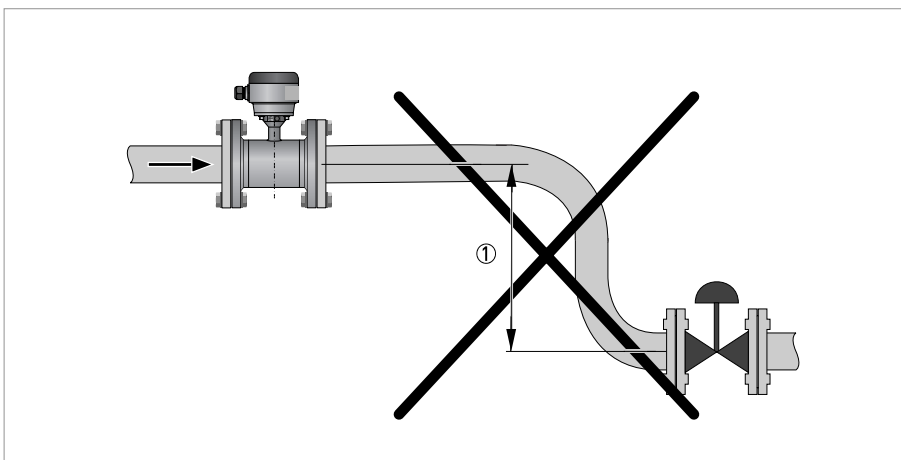

Figure 3-13: Vacuum

- ① ≥ 5 m

3.2.10 Mounting position

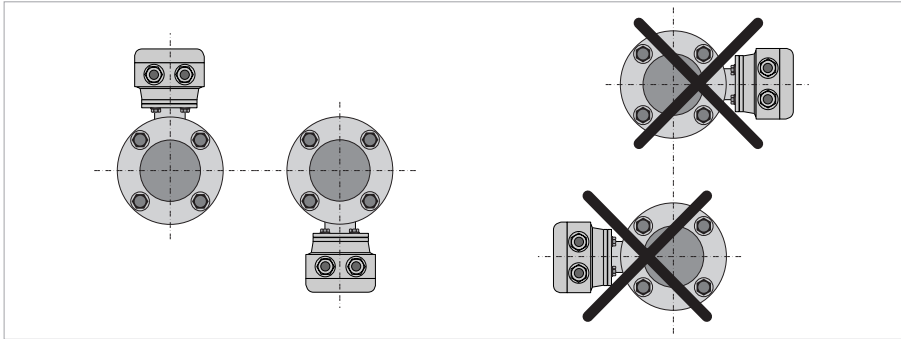

Figure 3-14: Mounting position

- Mount flow sensor either with signal converter aligned upwards or downwards.
- Install flow sensor in line with the pipe axis.
- Pipe flange faces must be parallel to each other.

3.3 Mounting

3.3.1 Torques and pressures

The maximum pressure and torques values for the flowmeter are theoretical and calculated for optimum conditions and use with carbon steel flanges.

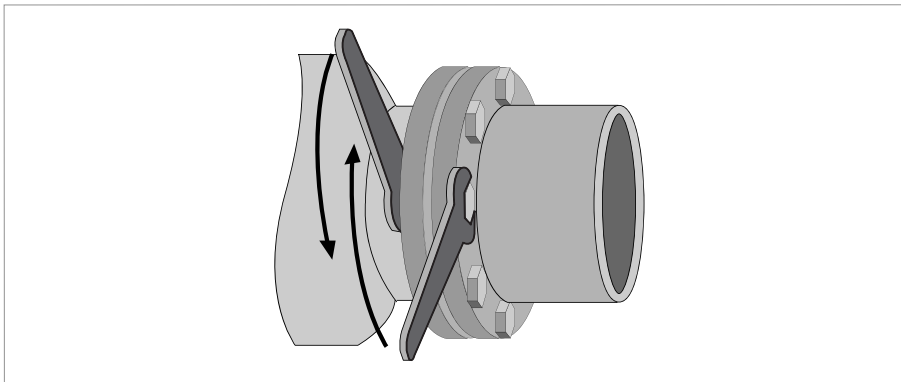

Figure 3-15: Tightening of bolts

- Always tighten the bolts uniformly and in diagonally opposite sequence.
- Do not exceed the maximum torque value.
- Step 1: Apply approx. 50% of max. torque given in table.
- Step 2: Apply approx. 80% of max. torque given in table.
- Step 3: Apply 100% of max. torque given in table.

Nominal size DN [mm]	Pressure rating	Bolts	Max. torque [Nm] ^①		
			Polyolefin	Polypropylene	Hard rubber
25	PN 40	4 x M 12	-	22	11
32	PN 40	4 x M 16	-	37	19
40	PN 40	4 x M 16	-	43	25
50	PN 40	4 x M 16	-	55	31
65	PN 16	② x M 16	-	51	42
65	PN 40	8 x M 16	-	38	21
80	PN 40	8 x M 16	-	47	25
100	PN 16	8 x M 16	-	39	30
125	PN 16	8 x M 16	-	53	40
150	PN 16	8 x M 20	-	68	47
200	PN 10	8 x M 20	68	-	68
200	PN 16	12 x M 20	45	-	45
250	PN 10	12 x M 20	65	-	65
250	PN 16	12 x M 24	78	-	78
300	PN 10	12 x M 20	76	-	76
300	PN 16	12 x M 24	105	-	105
350	PN 10	16 x M 20	75	-	75
400	PN 10	16 x M 24	104	-	104
450	PN 10	20 x M 24	93	-	93
500	PN 10	20 x M 24	107	-	107
600	PN 10	20 x M 27	138	-	138
700	PN 10	24 x M 27	163	-	163
800	PN 10	24 x M 30	219	-	219
900	PN 10	28 x M 30	205	-	205
1000	PN 10	28 x M 33	261	-	261

① The specified torque values are dependent on variables (temperature, bolt material, gasket material, lubricants, etc.) which are not within the control of the manufacturer. Therefore the values should be regarded as indicative only.

② DN65 / PN16 is available with standard 8 bolt holes.

Nominal size [inch]	Flange class [lb]	Bolts	Max. torque [lb.ft] ①		
			Polyolefin	Polypropylene	Hard rubber
1	150	4 x 1/2"	-	6.7	3.2
1 1/2	150	4 x 1/2"	-	13	9
2	150	4 x 5/8"	-	24	17
3	150	4 x 5/8"	-	43	29
4	150	8 x 5/8"	-	34	23
6	150	8 x 3/4"	-	61	38
8	150	8 x 3/4"	51	-	51
10	150	12 x 7/8"	58	-	58
12	150	12 x 7/8"	77	-	77
14	150	12 x 1"	69	-	69
16	150	16 x 1"	67	-	67
18	150	16 x 1 1/8"	105	-	105
20	150	20 x 1 1/8"	94	-	94
24	150	20 x 1 1/4"	133	-	133
28	150	28 x 1 1/4"	119	-	119
32	150	28 x 1 1/2"	191	-	191
36	150	32 x 1 1/2"	198	-	198
40	150	36 x 1 1/2"	198	-	198

① The specified torque values are dependent on variables (temperature, bolt material, gasket material, lubricants, etc.) which are not within the control of the manufacturer. Therefore the values should be regarded as indicative only.

- Pressures are applicable at 20°C / 68°F.
- For higher temperatures, the pressure ratings are as per ASME B16.5.

4.1 Safety instructions

All work on the electrical connections may only be carried out with the power disconnected. Take note of the voltage data on the nameplate!

Observe the national regulations for electrical installations!

Observe without fail the local occupational health and safety regulations. Any work done on the electrical components of the measuring device may only be carried out by properly trained specialists.

Look at the device nameplate to ensure that the device is delivered according to your order. Check for the correct supply voltage printed on the nameplate.

4.2 Grounding

The device must be grounded in accordance with regulations in order to protect personnel against electric shocks.

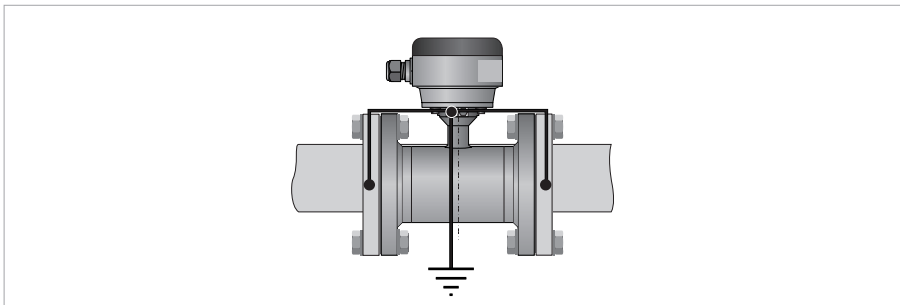

Figure 4-1: Grounding

① Metal pipelines, not internally coated. Grounding without grounding rings.

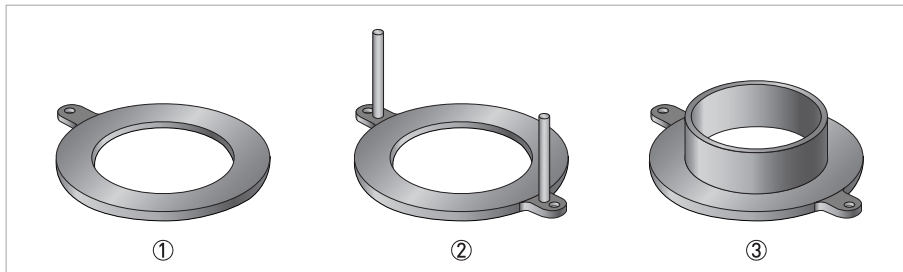

Figure 4-2: Different types of grounding rings

- ① Grounding ring number 1
- ② Grounding ring number 2
- ③ Grounding ring number 3

Grounding ring number 1:

- 3 mm / 0.1" thick (tantalum: 0.5 mm / 0.02")

Grounding ring number 2:

- 3 mm / 0.1" thick
- Prevents damage to the flanges during transport and installation
- Especially for flow sensors with PTFE liner

Grounding ring number 3:

- 3 mm / 0.1" thick
- With cylindrical neck (length 30 mm / 1.25" for DN10...150 / 3/8...6")
- Prevents damage to the liner when abrasive liquids are used

4.3 Virtual reference for IMT33A (C, W and F version)

The virtual reference option on the flow converter provides complete isolation of the measurement circuit.

Benefits of virtual reference:

- Grounding rings or grounding electrodes can be omitted.
- Safety increases by reducing the number of potential leakage points.
- The installation of the flowmeters is much easier.

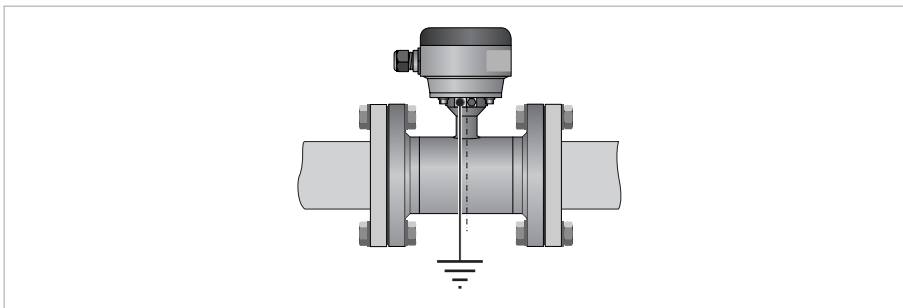

Figure 4-3: Virtual reference

Minimum requirements:

- Size: \geq DN10
- Electrical conductivity: \geq 200 μ S/cm
- Signal cable: max. 50 m / 164 ft, type DS

4.4 Connection diagrams

For the connection diagrams please refer to the documentation of the applicable signal converter.

Model	Description
	Foxboro® Model 9500A Magnetic Flow Sensor
9501A 951QA 951HA 9502A 952HA 9503A 9504A 9505A 9506A 9508A 9510A 9512A 9514A 9516A 9518A 9520A 9524A 9528A 9532A 9536A 9540A 9548A 9556A 9564A 9572A 9580A	Nominal diameter and liner DN25,1" PP DN32,1¼" PP DN40,1½" PP DN50,2" PP DN65,2½" PP DN80,3" PP DN100,4" PP DN125,5" PP DN150,6" PP DN200,8" Hardrubber DN250,10" Hardrubber DN300,12" Hardrubber DN350,14" Hardrubber DN400,16" Hardrubber DN450,18" Hardrubber DN500,20" Hardrubber DN600,24" Hardrubber DN700,28" Hardrubber DN800,32" Hardrubber DN900,36" Hardrubber DN1000,40" Hardrubber DN1200,48" Hardrubber DN1400,56" Hardrubber DN1600,64" Hardrubber DN1800,72" Hardrubber DN2000,80" Hardrubber
-1 -2 -3 -5 -A -B -M -N -4 -W	Nominal pressure PN 6 EN 1092-1 (DN 1200-2000) PN 10 EN 1092-1 (DN 200-2000) PN 16 EN 1092-1 (DN 25... 1000) PN 40 EN 1092-1 (DN25...600) 150 lbs RF ASME B 16.5 (1" ... 24") 300 lbs RF ASME B 16.5 (1" ... 24") JIS 20 K (DN 25 ... 40 1" ... 1 1/2") & (DN200 ... 600 8" ... 24") JIS 10 K (DN 50 ... 1400 2" ... 56") PN 25 EN 1092-1 (DN 200 ... 600) Class D AWWA (DN 700 ... 2000 28" ... 80")
0 1 3 5 A C D F T U V W X Y	Ex version ① non Ex EEx zone 1 (for IMT33A compact and field, IMT31A compact and wall only) Ex zone 2 (for IMT33A compact and field only) FM Class I DIV 2 (for IMT33A compact and field, IMT31A compact and wall only) cCSAus OL (for IMT33A compact and field, IMT31A compact and wall only) CSA Class I DIV 2 (for IMT33A compact and field, IMT31A compact and wall only) NEPSI zone 1 (for IMT33A compact and field only) IECEx zone 1 (for IMT33A compact and field, IMT31A compact and wall only) BE-Ex EAC (Belarus IMT33A compact and field, IMT31A compact and wall only) RU-Ex EAC (Russia IMT33A compact and field, IMT31A compact and wall only) KA- Ex EAC (Kazakhstan IMT33A compact and field, IMT31A compact and wall only) RU-EAC (Russia) KA-EAC (Kazakhstan) BE-EAC (Belarus)

Model	Description
	System design
1	Compact with aluminum converter housing / at converter
2	Compact with stainless steel converter housing / at converter
3	Modular / without
4	Separate with aluminum connection box / ½" NPT
5	Separate with aluminum connection box / PF ½
6	Separate with aluminum connection box / M20 x 1.5 A
A	Separate with stainless steel connection box / ½" NPT
B	Separate with stainless steel connection box / PF ½
C	Separate with stainless steel connection box / M20 x 1.5
	Converter model
0	without / modular
3	IMT31A (compact design)
4	IMT31A (wall mount version)
C	IMT33A (compact design)
D	IMT33A (field mount version)
E	IMT33A (wall mount version)
F	IMT33A (rack mount version)
K	IMT30A (compact design)
L	IMT30A (wall mount version)
	Lining
0	Standard (PFA for EEx Zone 1) (Hardrubber DN 200 ... 2000)
5	Hardrubber (4...6" / DN100...DN150)
8	Hardrubber (1...3" / DN25...80)
T	PP - provided for protection rings (Only up to 6" / DN150)
F	PO (PolyOlefin) (non Ex only)
	Electrodes (fixed)
1	Stainless steel DIN 1.4571 316 Ti
3	Hastelloy C4
6	Titanium
B	Hastelloy C22
	Construction of electrodes
1	fixed
	Housing- / flange material
1	Steel / steel St 37-c22/A105
3	Steel / st. steel DIN 1.4404 316 L
4	Steel st. steel dIN 1.4571/316Ti
A	1.4301 304 / steel St 37-C22 / A 105 (with st.st. conn. box.)
C	1.4301 304 / st. steel DIN 1.4404/316L (with st.st. conn. box.)
D	1.4301 304 / st. steel DIN 1.4571 316 Ti (with st.st. conn. box.)
	Protection class / dimension (face-to-face)
0	IP 66 / 67 / standard
1	IP 68 Field / standard (with stainless steel connection box)
2	IP 68 Factory / standard (with stainless steel connection box)
3	IP 66 / 67 / ISO 13359
4	IP 68 Field / ISO 13359 (with stainless steel connection box)
5	IP 68 Factory / ISO 13359 (with stainless steel connection box)
	Cable
0	Compact - without / separate DS
1	Separate BTS
2	Separate LIYCY (only for FM / CSA Class 1 DIV 2)
Y	Without

Model	Description
0 1 2 3 4 5 6 7 8 Y	Cable length Compact - none / separate - 5 m 15 ft 10 m 30 ft 15 m 45 ft 20 m 60 ft 25 m 75 ft 30 m 90 ft 40 m 120 ft 50 m 150 ft 100 m 300 ft Without
0 2 3	Calibration Standard 316/1.4401 tag plate (120 x 46 mm) 316/1.4401 tag plate (67 x 25 mm)
0 5 6 7 E N P R	Ring / Materials Without Ring #1 / Titanium Ring #1 / 1.4404 316 L Ring #1 / Hastelloy C22 Ring #3 / 1.4404 316 L Protection ring #2 / Titanium Protection ring #2 / 1.4404 316 L Protection ring #2 / Hastelloy C22
0	Construction requirements Standard
0	QA / QC requirements Standard
0	Ratio of CT-calibration Standard, R = 80

① Note: to maintain certification, make sure the transmitter being used is listed in the description

ORDERING INSTRUCTIONS

1. Model Number.
2. Flow Data:
 - a. Maximum, minimum, and normal flow rate.
 - b. Fluid composition and viscosity at operating temperatures.
 - c. Fluid density or relative density (specific gravity).
 - d. Maximum, minimum and normal operating temperatures.
 - e. Maximum, minimum and normal operating pressures.
 - f. Mating pipe schedule.
 - g. Type and location (distance) of upstream disturbance.
3. Calibration Information (analog output only); maximum flow rate 20 mA output.
4. Electric Classification.
5. Operational Selection and Accessories (see "Optional Selections and Accessories" section).
6. Customer Tag Data.

FLOWEXPERTPRO SIZING APPLICATION

Mobile application FlowExpertPro.com

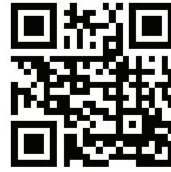

OTHER FOXBORO PRODUCTS

The Foxboro product lines offer a broad range of measurement and instrument products, including solutions for pressure, flow, analytical, temperature, positioning, controlling and recording. For a list of these offerings, visit our website at:

www.fielddevices.foxboro.com

Foxboro[®]
by **Schneider Electric**

Invensys Systems, Inc.
38 Neponset Avenue
Foxboro, MA 02035
United States of America
<http://www.fielddevices.foxboro.com>

Global Customer Support
Inside U.S.: 1-866-746-6477
Outside U.S.: 1-508-549-2424
Website: <http://support.ips.invensys.com>

Copyright 2015-2016 Invensys Systems, Inc.
All rights reserved.

Foxboro and FlowExpertPro are trademarks of Invensys Limited, its subsidiaries, and affiliates. All other trademarks are the property of their respective owners.

Invensys is now part of Schneider Electric.

APRIL 2016