

**PSS 1-8A8 A**

**Foxboro<sup>®</sup> Model 84C Flanged Body Intelligent Vortex Flowmeters with Temperature Compensation**

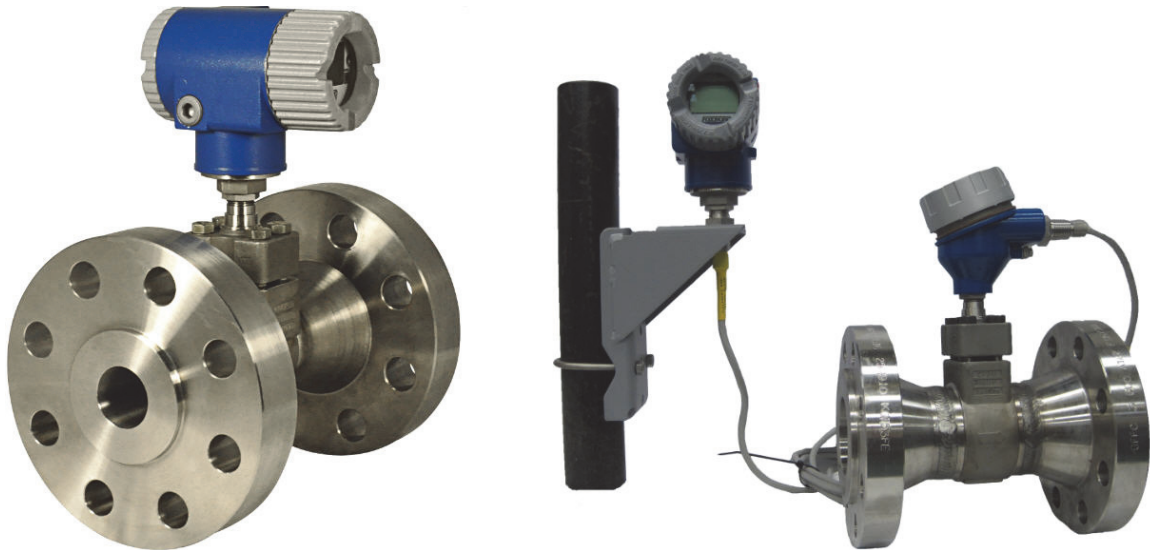

*The Model 84C flanged vortex flowmeter is an addition to the Foxboro<sup>®</sup> family of intelligent, high performance vortex flowmeters<sup>(1)</sup>. It is available with 4 to 20 mA, HART<sup>®</sup> 7, and pulse output. It is equipped with integral temperature compensation for flow measurement of saturated steam and user-defined liquids. An integral LCD indicator with pushbuttons is offered for local configuration.*

**FEATURES**

- ▶ Liquid, gas, or steam applications
- ▶ Compensation for mass flow of saturated steam based on ASME steam tables
- ▶ Compensation for mass flow of custom liquids
- ▶ Volumetric flow rate accuracy of  $\pm 0.5\%$  of reading in liquids and  $\pm 1.0\%$  in gas and steam
- ▶ Mass flow rate accuracy of  $\pm 1.4\%$  of reading in saturated steam
- ▶ Process temperature accuracy of  $\pm 1^\circ\text{F}$  ( $0.56^\circ\text{C}$ ) for saturated steam
- ▶ Flanged 3/4 to 12 in (DN15 to DN300) body
- ▶ High pressure up to Class 1500 and PN160
- ▶ *DirectSense*<sup>™</sup> technology
- ▶ Widest rangeability in class
- ▶ Low power versions available for use in battery or solar power applications
- ▶ An integrated temperature sensor for measuring process temperature
- ▶ ActiveTuning<sup>™</sup> algorithms:
  - ▶ Real time Reynolds number ( $R_D$ ) low flow correction down to  $R_D$  of 5000
  - ▶ Compensation for piping effects
  - ▶ Adaptive filtering and signal conditioning
- ▶ Pulse output capability in raw, frequency, or pulse (total) modes
- ▶ CE marked; complies with EMC European Union and PED Directives, and NAMUR NE 21 interference immunity requirement
- ▶ CRN Registered

1. For information on other flowmeters in the Model 84 family, refer to PSS 1-8A3 A (Style A Models 84F and 84W), PSS 1-8A5 A (Style A Model 84S), PSS 1-8A6 A (Low Power Style A Models 84F, 84W, and 84S), and PSS 1-8A7 A (Style B Model 84F).

## VORTEX SOLUTION FOR TEMPERATURE COMPENSATION

The Foxboro brand 84C Vortex flowmeter provides an integrated process fluid temperature measurement. With built-in ASME steam tables<sup>(2)</sup>, the Model 84C is the best solution for the mass flow metering of saturated steam. In addition, the 84C provides algorithms for temperature compensated mass flow of any user-defined liquid. With the field-proven advantages of the rest of the Model 84 family of vortex flowmeters, including DirectSense technology and ActiveTuning, the Foxboro 84C flowmeter provides the definitive solution for temperature compensation of saturated steam, and for liquids, it provides a low cost alternative to the more expensive mass flow solutions on the market.

## COMPLIANCE WITH EUROPEAN UNION DIRECTIVES

- ▶ Complies with Electromagnetic Compatibility Requirements of EMC Directive 2004/108/EC by conforming to the following EN and IEC Standards: EN 61326-1, IEC 61000-4-2 through 61000-4-6, and IEC 61000-4-11.
- ▶ Complies with NAMUR NE 21 Interference Immunity Requirement (EMC).
- ▶ Complies with Pressure Equipment Directive (PED) 97/23/EC.
- ▶ Complies with all applicable European Union Directives (CE Logo marked on product).

## DirectSense TECHNOLOGY ENSURES BEST PERFORMANCE AND RELIABILITY

*DirectSense* technology measures pressure pulses from vortex shedding directly, without losses due to mechanical linkages. Model 84C Vortex flowmeters are offered with all the advantages of *DirectSense* technology that the Model 84 Vortex flowmeter family delivers.

## INTEGRATED TEMPERATURE MEASUREMENT

The Model 84C Vortex flowmeter is equipped with an integrated Class A, 1000 ohm, platinum RTD temperature sensor which allows temperature compensation for density of saturated steam and user defined liquids. The temperature measurement is also provided as an output. The temperature sensor provides:

- ▶ Mass flow rate accuracy of  $\pm 1.4\%$  for saturated steam
- ▶ Process temperature accuracy of  $\pm 1^\circ\text{F}$  ( $0.56^\circ\text{C}$ )

## SIMPLIFIED START-UP

The flowmeter can be shipped preconfigured with flow data that you provide. Otherwise, you can easily configure the flowmeter for your specific process.

## ActiveTuning ALGORITHMS

### Reynolds Number

The patented ActiveTuning algorithm improves accuracy down to an  $R_D$  of 5000.

### Compensations for Piping Effects

When it is not possible to provide the recommended pipe diameters of unobstructed straight pipe upstream of the flowmeter, the 84C flowmeter can be configured to compensate for most of the common non-ideal upstream conditions, such as elbows and reducers. Straight runs as short as five pipe diameters can be configured to achieve full accuracy.

2. Saturated steam based on ASME International Steam Tables for Industrial Use (Second Edition), 2009.

### **Adaptive Filtering and Signal Conditioning**

A patented, adaptive filtering algorithm provides real-time, dynamic frequency filters that follow the vortex shedding frequency. This results in unsurpassed low-flow measurement capability and vibration immunity. This is incorporated with a digital smoothing algorithm that conditions the raw vortex signal to further enhance low-flow performance.

### **Tunable for Specific Operating Conditions**

Configurable parameters for Low Flow Cut-in and damping allow tuning for specific flow conditions.

### **COMPACT, EFFICIENT, AND DURABLE DESIGN**

The flowmeter mounts between ANSI or DIN EN 1092-1 raised face flanges. See "MODEL CODE" on page 22 for end connections offered with each line size. Other flange face surfaces can be used as a custom design.

The electronics housing is explosion proof and flameproof construction and provides environmental protection to the enclosed electronics. It is offered integrally mounted to the flowtube, or can be mounted remotely.

The flowmeter's simple, modular design requires minimum maintenance. Common, field replaceable parts are used, including the sensor assembly and amplifier. The amplifier can be replaced without interrupting the flow in the pipe. Since a single device is used for multiprocess-fluid applications, ordering is simplified and spare part needs are minimized.

### **LOW POWER OPTION**

A low power option is available for use with battery power and any form of recharging technology, such as solar arrays or alternators.

### **USABLE IN HAZARDOUS AREA LOCATIONS**

These flowmeters meet numerous agency requirements for hazardous locations.

### **MEASUREMENT INTEGRATION**

These flowmeters provide efficient integration of measurements into HART process control schemes. They operate by using a bidirectional digital signal superimposed on the 4 to 20 mA current signal (standard power -T version) or on the fixed 10 mA supply current (low power -L version). They are also offered with a pulse output. Remote communication of digital values plus status and configuration information can be achieved via HART communication protocol.

The following can be used to configure the Model 84C Vortex flowmeter:

- ▶ A HART communicator.
- ▶ A local digital indicator/configurator with pushbuttons.
- ▶ A PC-based configurator.

With HART, digital multidropping is permitted. This is the connection of several transmitters to a single communications line. Up to 16 transmitters can be connected on a single twisted pair of wires or over leased telephone lines.

### **mA OUTPUT**

In addition to the standard HART digital signal, Vortex flowmeters produce a milliamp output signal. For standard power 84C Vortex flowmeters, you can map a measurement to the HART primary variable (PV), and this measurement will drive the 4 to 20 mA analog output. For low power 84C Vortex flowmeters, the mA output is fixed at 10 mA.

## PULSE OUTPUT

Vortex flowmeters can also produce a pulse signal in addition to the standard HART digital signal and 4 to 20 mA analog signal. Pulse output can be configured in one of the following modes.

- ▶ **Raw** mode generates a pulse frequency according to the detected raw vortex frequency after filtering.
- ▶ **Frequency** mode generates a pulse frequency proportional to a mapped measurement. Valid measurement mappings are shown in Table 16.
- ▶ **Pulse** mode generates one pulse output per given quantity of material flowing through the sensor.

## TOTALIZERS

The 84C Vortex flowmeter provides three separate totalizers that accumulate flow measurements. To allow you to track different types of flow measurements, each totalizer can be mapped, configured, and operated independently.

## REMOTE MOUNTED ELECTRONICS HOUSING

Remote mounting is offered to allow access to the amplifier and other housing electronics when the measurement is not in an easily accessible location. The remote housing is supported by a bracket, which in turn mounts to a surface or to a nominal 2-inch or DN50 pipe. This housing can be located up to a cable length of 50 ft (15.2 m) from the flowtube without loss of low level signal.

## LOCAL DIGITAL INDICATOR/CONFIGURATOR

The Model 84C flowmeter is offered with an optional multi-line local digital display, which serves as both a local configurator and measurement indicator.

The flowmeter can be easily configured in Setup mode using four pushbuttons on the front of the transmitter and an intuitive menu system.

The indicator screen, which displays real-time flowmeter measurements, is fully configurable. Depending on your application and the flowmeter's model code, you can customize the indicator to manually or automatically cycle among one or more flowmeter measurements. The indicator screen also displays rollover counters for totalizer readings, and any errors or warnings that exist.

## SELF-DIAGNOSTICS

The flowmeter uses many diagnostic functions including temperature sensor continuity checks. These diagnostic functions are performed at startup and continuously in the background.

The flowmeter also has a built-in self-test function for verification of the health of the electronics module.

OPERATING CONDITIONS

**FlowExpertPro™ SIZING TOOL**

The FlowExpertPro sizing tool is an application primarily used to size Foxboro brand flowmeters, but also ensures that you have selected the proper flowmeter type for your particular application. This meter selection tool is provided to all users. You can run the FlowExpertPro sizing tool from a free website or on mobile devices running the iOS operating system.

In addition to flowmeter selection and sizing, the FlowExpertPro program includes the following features:

- ▶ Incorporates a large library of the physical properties of typical process fluids.
- ▶ Displays results in tabular or graphic format.
- ▶ Allows you to save, print, or e-mail results.
- ▶ Provides reference to applicable flowmeter Product Specification Sheets (PSSs) and other related flowmeter documentation.

The program calculates minimum and maximum flow rates, rangeability, pressure loss, and Reynolds Number using established flow equations. It also allows for material and flange selection, and provides ANSI or DIN flange recommendations for predicted flow pressure and temperature. Visit [www.FlowExpertPro.com](http://www.FlowExpertPro.com) to use the web-based tool, or scan the appropriate QR Code below to access the web tool or mobile application. Contact Global Customer Support for further information and technical support.

Scan for access to  
[FlowExpertPro.com](http://FlowExpertPro.com)



Scan for access to  
mobile application



**OPERATING CONDITIONS**

Influence	Factory Calibration Conditions (a)	Operating Limits (b)
Process Fluid	Clear Water	Liquid, Gas, and Steam
Process Temperature <ul style="list-style-type: none"> <li>▶ Std. Temp. Version/Fluorolube Fill</li> <li>▶ Std. Temp. Version/Silicone Fill</li> <li>▶ High Temp. Version/Unfilled (c)</li> </ul>	<ul style="list-style-type: none"> <li>▶ 70° to 85°F (20° to 30°C)</li> <li>▶ 70° to 85°F (20° to 30°C)</li> <li>▶ 70° to 85°F (20° to 30°C)</li> </ul>	<ul style="list-style-type: none"> <li>▶ 0° and +200°F (-20° and +90°C)</li> <li>▶ 0° and +400°F (-20° and +200°C)</li> <li>▶ 300° and 500°F (150° and 260°C)</li> </ul>
Ambient Temperature (Housing) <ul style="list-style-type: none"> <li>▶ with Indicator/Configurator</li> <li>▶ without Indicator/Configurator</li> </ul>	<ul style="list-style-type: none"> <li>▶ 70° to 85°F (20° to 30°C)</li> <li>▶ 70° to 85°F (20° to 30°C)</li> </ul>	<ul style="list-style-type: none"> <li>▶ 0° and +176°F (-20° and +80°C) (d)</li> <li>▶ -40° and +176°F (-40° and +80°C) (d)</li> </ul>
Relative Humidity	50 to 90%	0 and 100%
Supply Voltage	24 ±0.5 V dc	15.5 and 42 V dc (see Figure 2) 10 and 42 V dc for Low Power version (e)

- a. The factory calibration conditions assume: ANSI Schedule 160 process piping for 2-, 3-, and 4-inch line sizes using Class 1500 flanges, 6-inch (152.4 mm) and 8-inch (203.2 mm) line sizes using Class 900 and Class 1500 flanges, and DN150 and DN200 line sizes using PN160 flanges; all other line sizes and pressure options assume ANSI Schedule 40 process piping; flanges bored to interfacing pipe I.D.; piping and flowmeter body bores aligned to within 2% of meter bore; gaskets are 0.125 in (3.18 mm) thick and not protruding into pipeline; a minimum of thirty pipe diameters of straight pipe upstream and five pipe diameters downstream of flowmeter; clear water is free from air or particles.
- b. Limits are based on nonflashing, noncavitating conditions. A minimum positive back pressure is required for proper operation to avoid these effects.
- c. Sensor Options A and B are rated to 500°F (260°C) maximum with Multivariable selection T.
- d. The 176°F (80°C) temperature is extended to 185°F (85°C) with certain electrical approvals or certifications. Refer to Electrical Safety Specifications table.
- e. Supply current is fixed at a constant 10 mA for Electronics Version selection L and remains in operation down to a minimum terminal voltage of 10 V dc. See "Power Supply Requirements (Low Power Versions)" on page 10.

**PERFORMANCE SPECIFICATIONS**

*Under calibrated operating conditions unless otherwise stated*

**Factory Calibrated Flow Ranges**

Nominal Meter Size	Nominal Mean K-Factor in Pulses/ft <sup>3</sup> (Pulses/L) (a)	Factory-Calibrated Flow Range for Water (b)		
		Range in US gpm	Range in L/s	Range Reynolds Number (R <sub>D</sub> )
3/4 in (DN15)	5,580 (197)	6.9 to 34	0.43 to 2.1	30,000 to 150,000
1 in (DN25)	2,250 (79.5)	8.9 to 56	0.56 to 3.5	30,000 to 190,000
1 1/2 in (DN40)	570 (20.1)	14 to 140	0.88 to 8.7	30,000 to 300,000
2 in (DN50)	258 (9.11)	18 to 230	1.1 to 15	30,000 to 380,000
2 in (DN50) Class 1500	389 (13.74)	16 to 203	1 to 12.8	30,000 to 380,000
3 in (DN80)	78.7 (2.78)	34 to 500	2.1 to 32	38,000 to 570,000
3 in (DN80) Class 1500	103 (3.64)	32 to 475	2 to 30	38,000 to 570,000
4 in (DN100)	34.8 (1.23)	59 to 890	3.7 to 56	50,000 to 750,000
4 in (DN100) Class 1500	47.29 (1.67)	55 to 818	3.4 to 51.6	50,000 to 750,000
6 in (DN150)	10.00 (0.353)	140 to 2,000	8.5 to 130	76,000 to 1,100,000
6 in (DN150) Class 900, Class 1500, PN160	13.68 (0.483)	125 to 1,812	7.9 to 114.3	76,000 to 1,100,000
8 in (DN200)	4.26 (0.150)	240 to 3,600	15 to 220	100,000 to 1,500,000
8 in (DN200) Class 900, Class 1500, PN160	5.98 (0.211)	216 to 3,244	13.6 to 204.6	100,000 to 1,500,000
10 in (DN250)	2.19 (0.0773)	395 to 5,768	24.9 to 363.9	130,000 to 1,900,000
12 in (DN300)	1.32 (0.0466)	578 to 8,305	36.4 to 524.0	160,000 to 2,300,000

- a. The K-factor is the relationship between input (volumetric flow rate) and the output (pulse rate). Reference K-factor is the arithmetic mean value of K-factor over a designated flow rate range (reference conditions). The mean K-factor is derived as:  

$$\text{Mean K-factor} = (\text{KMAX} + \text{KMIN}) / 2$$
 where KMAX is the maximum K-factor and KMIN is the minimum K-factor over the calibrated flow range.
- b. Factory calibrated Reynolds Number range applies to standard temperature sensor without isolation valve. Other sensor selections and manifold selections may alter the calibration range. For sizing tools and specific calibration ranges, visit [www.FlowExpertPro.com](http://www.FlowExpertPro.com).

REFERENCE ACCURACY

**Volumetric Flow for Liquids**

Accuracy within the calibrated range is as follows (also see Figure 1):

- ▶ Above 30,000  $R_D$ ;  $\pm 0.5\%$
- ▶ Between 20,000 and 30,000  $R_D$ ;  $\pm 1.0\%$
- ▶ Between 5,000 and 20,000  $R_D$ ;  $\pm 2.0\%$

Figure 1. Flowmeter Accuracy for Liquids

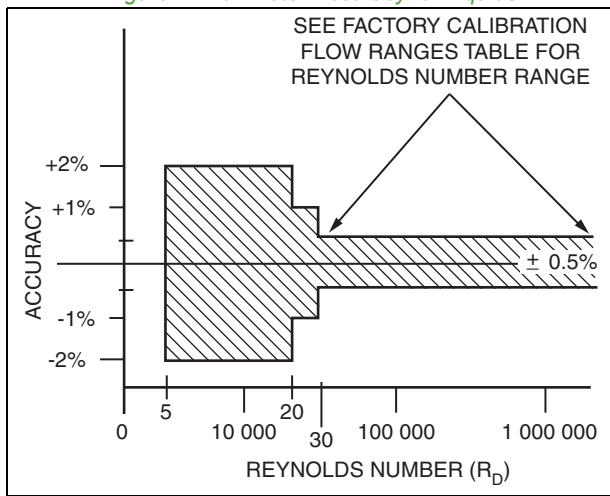

**Volumetric Flow for Gases and Steam**

Accuracy within the calibrated range is as follows:

- ▶ Above 20,000  $R_D$ ;  $\pm 1.0\%$
- ▶ Between 5,000 and 20,000  $R_D$ ;  $\pm 2.0\%$

**NOTE**

To achieve the fluid accuracies listed above, the flowing density and viscosity must be configured. To determine accuracy for specific applications and use other sizing tools, visit [www.FlowExpertPro.com](http://www.FlowExpertPro.com).

**Mass Flow for Saturated Steam<sup>(3)</sup>**

Mass flow accuracy for velocities from 33 to 250 ft/s (10 to 76 m/s) and temperatures greater than 300°F (149°C):

- ▶  $\pm 1.4\%$  of rate

**Process Temperature for Saturated Steam<sup>(3)</sup>**

Process temperature accuracy for velocities greater than 33 ft/s (10 m/s) and for temperatures greater than 300°F (149°C):

- ▶  $\pm 1^\circ\text{F}$  ( $\pm 0.56^\circ\text{C}$ )

3. These specifications assume the flowmeter is insulated per MI 019-222.



## EXTERNAL INFLUENCES

### Supply Voltage (Within Stated Limits)

- ▶ With Pulse Output: No effect on accuracy
- ▶ With Analog Output: Less than 0.005% per volt
- ▶ With Digital Output: No effect on accuracy

### Ambient Temperature (Amplifier only)

- ▶ With Pulse Output:  $\pm 0.01\%$  of reading from  $-40^{\circ}$  to  $+176^{\circ}\text{F}$  ( $-40^{\circ}$  to  $+80^{\circ}\text{C}$ )<sup>(4)</sup>
- ▶ With Analog Output: For  $50^{\circ}\text{F}$  ( $28^{\circ}\text{C}$ ) change in ambient temperature within operative limits.
  - Zero (4 mA):  $\pm 0.02\%$  of span maximum
  - Span (16 mA):  $\pm 0.1\%$  of span maximum
- ▶ With Digital Output:  $\pm 0.01\%$  of reading from  $-40^{\circ}$  to  $+176^{\circ}\text{F}$  ( $-40^{\circ}$  to  $+80^{\circ}\text{C}$ )<sup>(4)</sup>

### Relative Humidity

No effect if covers and conduit seals are properly installed.

### EMI and RFI

The flowmeters meet the EMI and RFI requirements of EN 61326-1.

### Vibration

The flowmeter complies with IEC 60068-2-6 for 10 to 500 Hz up to 2 “g”.

### Switching and Indirect Lightning Transients

The transmitter can withstand a transient surge up to 2000 V common mode or 1000 V normal mode without permanent damage. Transmitter complies with ANSI/IEEE C62.41-1980 and IEC 61000-4-5.

Complies with Electromagnetic Compatibility requirements of European EMC Directive 2004/108/EC by conforming to EN 61326-1 and IEC 61000-4-2 through 61000-4-6.

### RFI

Complies with IEC 61000-4-3.

---

4. The  $176^{\circ}\text{F}$  ( $80^{\circ}\text{C}$ ) temperature may be extended to  $185^{\circ}\text{F}$  ( $85^{\circ}\text{C}$ ). Refer to “ELECTRICAL SAFETY SPECIFICATIONS” on page 18.



FUNCTIONAL SPECIFICATIONS

**Remote Digital Communication**

Remote digital communications are carried out via a HART Communicator or PC-based configurator at a communication rate of 1200 baud, and a rated communication distance of 6000 ft (1800 m). Remote digital communication can also be carried out through a control system.

**Local Communication/Configuration**

In addition to remote communications, a local digital indicator/configurator with pushbuttons is also available for local interrogation and configuration.

**Communication Format**

- ▶ Analog 4 to 20 mA with HART superimposed
- ▶ HART communications with fixed mA output

Table 1. Remote Communication Parameters

Parameter	HART Analog or Digital Multidrop Mode
Remote Configurator/Communicator	HART Communicator or PC-Based Configurator
Communication Rate	1200 baud
Communication Distance (Rated)	6000 ft (1800 m)
Measurement Update	5 times/s
Raw Pulse Measurement Update	Vortex Shedding Frequency

**Write Protect Jumper**

A write protect jumper provides additional security by allowing or preventing the local or remote configurators from writing to the electronics. This write protection capability meets the security requirements of ISA-584.01-1986.

**NOTE**

Without the jumper installed, the Vortex flowmeter electronics module is write protected.

**Password Protection**

This is provided in the local display/configurator mode to assure operating security. A second level of protection is provided for configuration security.

**On-Line Diagnostics**

The flowmeter uses many internal diagnostic functions including hardware checks and internal code and database validation. The 4 to 20 mA output follows the NAMUR 43 standard where:

- ▶ Fail Low is  $\leq 3.6$  mA
- ▶ Under Range is  $< 3.8$  mA
- ▶ Over Range is  $> 20.5$  mA
- ▶ Fail High is  $\geq 21.0$  mA

The 4 to 20 mA output can be configured to fail high or fail low.

**Self-Test**

The transmitter initiates self-tests to verify the health of the transmitter electronics. This test uses an internally generated frequency signal.

**Temperature Sensor Diagnostics**

Software running in the Vortex flowmeter provides temperature sensor continuity checks.

**Power Supply Requirements (Standard Power Versions)**

**Supply Current**

- ▶ Digital Mode: 10 mA dc nominal
- ▶ Analog Mode: 22 mA dc maximum
- ▶ Pulse Output: 20 mA dc maximum

**Supply Voltage**

- ▶ 15.5 to 42 V dc, depending on electrical safety approvals and certifications. Refer to Figure 2.

**NOTE**

When operating at ambient temperatures below -20°F (-29°C), it is important to maintain a minimum loop voltage of 15.75 V dc to maintain remote configurator communications capability.

*Figure 2. Supply Voltage vs Output Load for 4 to 20 mA Output*

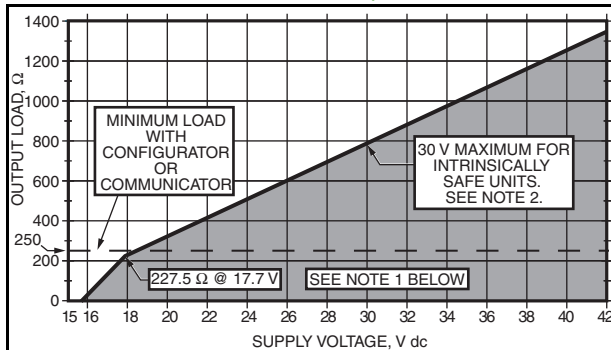

**NOTE**

1. The transmitter will function with an output load less than 250 Ω provided that a PC-based configurator or HART communicator is not connected to it. Connecting a PC-based configurator or HART communicator while operating in this area may cause output disturbances and/or communication problems.
2. With intrinsically safe certifications with a 24 V dc supply, an active barrier is required.

**Power Supply Requirements (Low Power Versions)**

**Supply Current**

- ▶ 10 mA dc nominal

**Supply Voltage Limits**

- ▶ 10 and 42 V dc

**NOTE**

For proper operation, 10 V dc must be maintained at the flowmeter terminals. For HART communications, a 250 Ω load resistor must be included in the power supply loop and a supply voltage of 12.5 V dc must be maintained. See installation MI for typical installation topologies.

**Output Damping**

Damping smooths the flow rate output, and optimizes the flowmeter's response time to the control system. Damping is an exponential filter, 85% recovery time to an input step that is 80% of span, with a selectable time constant; it can be set between 0 and 32 seconds. An eight second damping factor will pass 85% of the step change in this time period. Damping applies to all outputs except the Raw Pulse Output where no damping is applied to the direct vortex shedding frequency.

**Response Time (Without Damping)**

**Analog Mode**

0.5 second or the vortex shedding period for frequencies less than 2 Hz.

**Digital Mode**

0.5 second or the vortex shedding period for frequencies less than 2 Hz.

**Pulse Output**

- ▶ Raw mode: Vortex shedding frequency
- ▶ Frequency or Pulse mode: 0.25 s or the vortex shedding period for frequencies less than 2 Hz.

## Outputs

These flowmeters with full-featured electronics can support the following outputs:

- ▶ HART Version -T: Digital and 4 to 20 mA output, with a pulse output
- ▶ HART Version -L: Digital output with a pulse output

### Analog Output

Flow rate available as a 4 to 20 mA signal with the 20 mA value being set by the configured full range flow rate.

### Digital Output

Digital information is superimposed on a 4 to 20 mA signal (standard power versions) or the power supply loop (low power versions) at 1200 baud (see Table 1). For low power versions, output is fixed at 10 mA.

### Pulse Output

The pulse output can be configured with the full-function electronics in one of the following modes:

- ▶ Raw Mode: The vortex shedding frequency is directly passed through, providing an instantaneous, nondampened frequency output.
- ▶ Frequency mode: The frequency of this output is a 50% duty cycle pulse output with a frequency range of 0 to 10,000 Hz, proportional to zero flow to the full range flow rate/upper range value (URV).
- ▶ Pulse mode: The frequency of this output is also a 50% duty cycle pulse output that is configured to provide a pulse when a determined volumetric/totalized unit has flowed through the meter.

## Pulse Output Specifications

The pulse output is an externally powered 2-wire transistor switch type output. This output can be configured using any applicable configuration device to select one of three pulse output modes: raw, frequency, and pulse. The following specifications apply to all three types of pulse output modes:

- ▶ Isolated 2-Wire Transistor Switch
- ▶ Applied Voltage: 5 to 30 V dc
- ▶ Maximum "ON" State Voltage Drop: 1.0 V dc
- ▶ Maximum "ON" State Current: 20 mA
- ▶ Reverse polarity protected
- ▶ Short circuit protected
- ▶ Connectable to pulse counters.

## Output Combinations (4 to 20 mA Outputs)

Flowmeter wired as a 2-wire device without pulse output, and as a 4-wire device with pulse output.

## Flowmeter Ranges

Flowmeter is shipped with the flow range specified in the sales order or with a default flow range equal to the meter capacity. You can rerange the flowmeter and keep the same flow rate units, choose new flow rate units from a built-in menu-selectable list, or enter custom flow rate units. Table 2 is included for reference only.

To determine flow velocity limits and use other sizing tools, visit [www.FlowExpertPro.com](http://www.FlowExpertPro.com).

### Nominal Flow Velocity Limits

These limits can be calculated using Table 2. In the table,  $\rho_f$  is the fluid density at flowing conditions in lb/ft<sup>3</sup> for U.S. customary units, or in kg/m<sup>3</sup> for metric (SI) units. The specifications apply for most applications, but can deviate slightly for some combinations of density and line size.

Table 2. Nominal Flow Velocity Limits

Range Limit	Standard Temperature Range		Extended Temperature Range	
	ft/s	m/s	ft/s	m/s
Lower (a)	$2.5/\sqrt{\rho_f}$	$3.0/\sqrt{\rho_f}$	$5.0/\sqrt{\rho_f}$	$6.0/\sqrt{\rho_f}$
Upper	$250/\sqrt{\rho_f}$	$300/\sqrt{\rho_f}$	$250/\sqrt{\rho_f}$	$300/\sqrt{\rho_f}$

a. Values given for lower range velocity limit are at the lowest LFCI setting.

### Reference K-Factor

The reference K-factor is a coefficient that specifies the flowmeter calibration and is expressed as pulses per unit volume, where pulses/unit volume = pulses per second divided by volume flow per second.

The reference K-factor is the arithmetic mean value of K over the factory-calibrated flow range. It is determined at the factory by actual flow calibration with water by comparison to a master flowmeter calibration, or by actual static weight. Both calibrations are traceable to NIST. The reference K-factor is entered in the flowmeter database and stamped on the data plate. Once established, this K-factor is available to gas, liquid, or steam.

### Flowing K-Factor

The flowing K-factor is computed from the K-reference expressed in specified flowing units, and can be corrected for the following:

- ▶ Process Temperature
- ▶ Mating Pipe
- ▶ Upstream Disturbances

### Process Temperature Effect on K-Factor

There is an effect on the reference K-factor due to a diameter change of the flowtube bore with temperature. The effect is -0.3% of flow rate per 100°F (55°C) increase in temperature. These flowmeters will automatically recompute a flowing K-factor based on detected changes in process temperature.

### K-Factor Bias

Provisions are made in the configuration menu to bias the flowmeter K-factor by a percent (%) value. Flowing K-factor value will be automatically recalculated when the % bias is entered.

### Static Pressure Limits

#### Minimum Static Pressure

The minimum static pressure is that pressure which is sufficient to prevent flashing and meet the pressure drop requirements to attain maximum flow rate. For sizing tools, visit [www.FlowExpertPro.com](http://www.FlowExpertPro.com).

#### Maximum Static Pressure

3750 psig (258.6 bar) (25855 kPa) or that imposed by flange rating.

To determine the pressure drop for Model 84C Vortex flowmeters and use other sizing tools, visit [www.FlowExpertPro.com](http://www.FlowExpertPro.com).

**Minimum Back Pressure (Volatile Liquids or Low Pressure Conditions)**

Any condition that tends to contribute to the release of vapor from the liquid (flashing, which may also induce cavitation) shall be avoided by proper system design and operation of the flowmeter within the rated flow rate range. Location of the flowmeter should consider the need for using a back-pressure valve, or for increasing inlet pressure. To avoid flashing and to ensure stable vortex generation, the minimum back pressure should be:

$$P_G = (3)(\Delta P) + (1.25)(p_v) - (p_{atm})$$

where

- $P_G$  = Gauge pressure in kPa or psi five pipe diameters downstream of the flowmeter
- $\Delta P$  = Pressure loss in psi or kPa
- $p_v$  = Vapor pressure at line conditions in psi or kPa absolute
- $p_{atm}$  = Atmospheric pressure in psi or kPa absolute

**Flange Pressure-Temperature Ratings**

See MI 019-222 for ANSI and DIN flange pressure-temperature ratings. These ratings are also embedded in the FlowExpertPro sizing tool. Also note the temperature limit when fluorolube fill (200°F/90°C) or silicone fill (400°F/200°C) is used, or when no fill (500°F/260°C) is used with extended temperature applications.

**Functional Block Diagrams**

*Figure 3. HART 4 to 20 mA Topology*

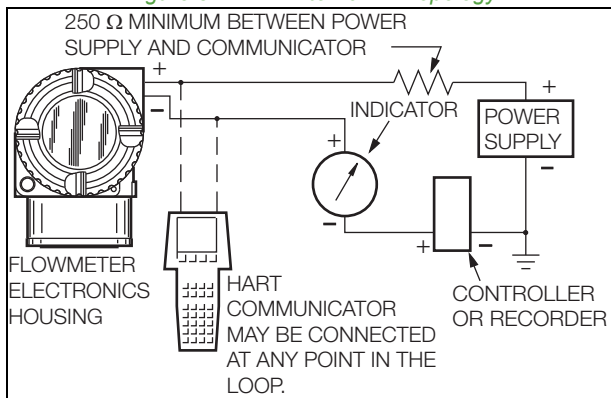

*Figure 4. HART Multidrop Topology*

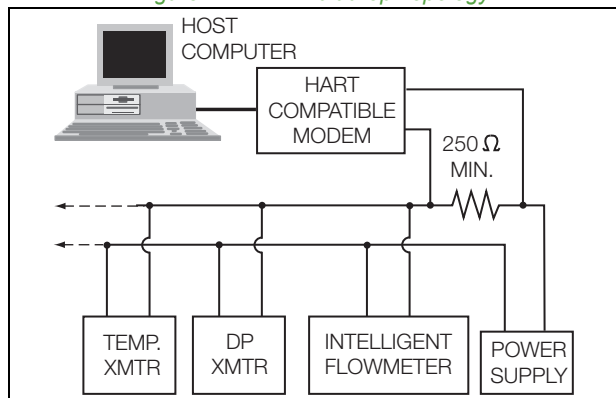

PHYSICAL SPECIFICATIONS

Process-Wetted Parts

Table 3. Flowmeter Body, Shedder Bar, and Flanges

Line Sizes	Body/Shedder Bar	Flange
3/4 to 4 inch (15 to 100 mm) (Codes 008 to 040)	Cast 316 SS, CF8M	316 SS
6 to 8 inch (150 to 200 mm) (Codes 060 to 080)	Cast 316 SS, CF8M	304 SS
10 and 12 inch (250 and 300 mm) (Codes 100 and 120)	Fabricated 304 SS per ASTM 312	304 SS per ASTM A182 Grade F304/F304L

Table 4. Gaskets and Flow Dam (Sensor Seals)

Sensor Type	Gasket Material	Flow Dam Material
Standard Temperature Sensor	PTFE	PTFE
High Temperature Sensor	316 SS	316 SS/grafoil
	Nickel alloy CW2M (a)	Nickel alloy CW2M/grafoil (a)

a. Equivalent to Hastelloy® C-4C.

Flowmeter Mounting

Flowmeter can be located in a pipeline which may run in any direction from the vertical (upward flow) to the horizontal. The electronics housing can also be rotated 270° (in 90° increments) with respect to the body. A vertical pipeline is preferred for batch operations to provide improved full line assurance. See "RECOMMENDED MOUNTING ARRANGEMENTS" on page 20.

Electrical Connections

Field wires enter through 1/2 NPT or M20 conduit threaded entrances on either side of the electronics housing. Wires terminate under screw terminals and washers on terminal block (see Figure 5) in the field terminal compartment. Unused entrance is plugged to ensure moisture and RFI/EMI protection.

Electronics Housing and Housing Covers

A two compartment housing separates the electronics from the field connections. Housing and covers are low copper, die-cast aluminum alloy with an epoxy finish. Buna-N O-ring seals are used to seal the housing covers, housing neck, and terminal block.

Figure 5. Terminal Block

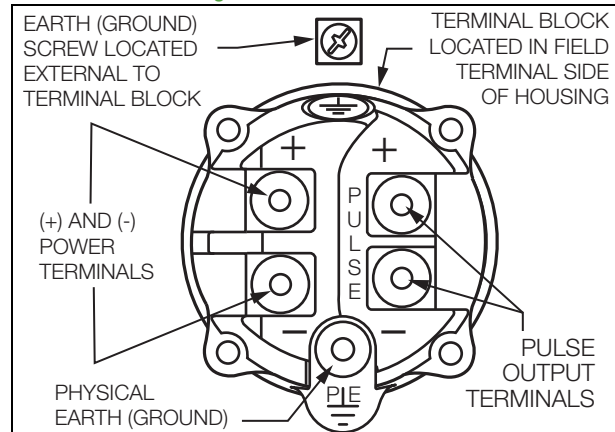

**Electronics Module**

Printed wiring assemblies (PWAs) are conformally coated for moisture and dust protection.

**Environmental Protection**

The electronics housing has the dust tight and weatherproof rating of IP66 as defined by IEC 60529, and provides the environmental and corrosion resistant protection rating of NEMA 4X.

**Data Plate**

Stainless steel data plate encircles and is secured to the lower part of the electronics housing. It includes conventional Model and operating data, such as the factory calibration factor (K-factor). If additional tag data space is required, an optional Stainless Steel Customer Tag is offered.

**NACE Certification**

The Model 84C flowmeters have been designed to meet the requirements of NACE Standard MR-0175-2003 for use in H<sub>2</sub>S Sour Oilfield environments. The design and process wetted materials also comply with NACE Standard MR-0103-2007 for use in corrosive petroleum refining environments. A NACE compliance certificate is available by selecting the -Q option.

**Dimensions**

Refer to “DIMENSIONS – NOMINAL” on page 26 for general outline data. For more dimensional details, refer to DP 019-127.

**Approximate Weight**

Refer to Table 5. Weights shown are approximate and are meant as a guide.

Standard temperature flowmeter weights are listed for integrally mounted electronics housings. There is a slight weight difference for high temperature flowmeters (adds about 1 lb (0.5 kg)), and for remote mounted housings (housing replaced by connector head assembly/junction box). The electronics housing itself weighs about 4 lbs (2 kg) and varies slightly depending on whether indicator/configurator, and/or extended housing covers are used.

**Table 5. Model 84C Appropriate Weight**

Nominal Line Size	Flange	Material	Weight, lb (kg)
0.75 in	Class 150	316 SS	10.4 (4.71)
0.75 in	Class 1500	316 SS	19.3 (8.75)
1 in	Class 150	316 SS	12.2 (5.53)
1 in	Class 1500	316 SS	24.3 (11.02)
1.5 in	Class 150	316 SS	16.7 (7.57)
1.5 in	Class 1500	316 SS	34.5 (15.65)
2 in	Class 150	316 SS	20.9 (9.48)
2 in	Class 1500	316 SS	54.2 (24.58)
3 in	Class 150	316 SS	43.0 (19.50)
3 in	Class 1500	316 SS	109.7 (49.76)
4 in	Class 150	316 SS	46.4 (21.05)
4 in	Class 1500	316 SS	155.9 (70.72)



Table 5. Model 84C Approximate Weight (Continued)

Nominal Line Size	Flange	Material	Weight, lb (kg)
6 in	Class 150	316 SS	77.6 (35.2)
6 in	Class 600	316 SS	178.1 (77.92)
6 in	Class 1500	316 SS	357.0 (161.93)
8 in	Class 150	316 SS	127.3 (57.74)
8 in	Class 600	316 SS	289.4 (131.26)
8 in	Class 1500	316 SS	657.2 (298.1)
10 in	Class 150	304 SS	160.0 (72.57)
10 in	Class 600	304 SS	476.2 (216.0)
12 in	Class 150	304 SS	252.4 (114.48)
12 in	Class 600	304 SS	540.4 (245.12)
DN15	PN40	316 SS	12.3 (5.58)
DN15	PN100	316 SS	16.2 (7.35)
DN25	PN40	316 SS	13.4 (6.08)
DN25	PN160	316 SS	19.1 (8.66)
DN40	PN40	316 SS	17.9 (8.12)
DN40	PN160	316 SS	28.2 (12.79)
DN50	PN40	316 SS	21.7 (9.84)
DN50	PN160	316 SS	38.4 (17.42)
DN80	PN40	316 SS	33.3 (15.10)
DN80	PN160	316 SS	58.6 (26.58)
DN100	PN40	316 SS	44.4 (20.14)
DN100	PN160	316 SS	81.2 (36.83)
DN150	PN16	316 SS	61.5 (27.89)
DN150	PN160	316 SS	195.8 (88.81)
DN200	PN16	316 SS	94.8 (43)
DN200	PN160	316 SS	356.7 (161.79)
DN250	PN16	304 SS	143.6 (65.13)
DN250	PN100	304 SS	421.6 (191.23)
DN300	PN16	304 SS	204.4 (92.71)
DN300	PN100	304 SS	618.0 (280.32)

Table 6. Body Internal Dimensions — Body Style F — Flanged for Schedule 80 Bore (a)

ANSI/DIN Nominal Line Size		Bore (ID)	
in	mm	in	mm
0.75	15	0.74	18.8
1.00	25	0.96	24.3
1.50	40	1.50	38.1
2.00	50	1.94	49.2
3.00	80	2.87	72.9
4.00	100	3.83	97.2
6.00	150	5.76	146.3
8.00	200	7.63	193.8
10.00	250	9.56	242.9
12.00	300	11.38	289.0

- a. Dimensions are for following flange offerings:
- 3/4"-1.5": ANSI Class 150-1500
  - DN15-DN40: PN40-PN160
  - 2"-4": ANSI Class 150-900
  - DN50-DN100: PN40-PN160
  - 6"-12": ANSI Class 150-600
  - DN150-300: PN16-PN100

Table 7. Body Internal Dimensions — Body Style F — Flanged for Schedule 160 Bore (a)

ANSI/DIN Nominal Line Size		Bore (ID)	
in	mm	in	mm
2.00	50	1.69	42.8
3.00	80	2.63	66.7
4.00	100	3.44	87.3
6.00	150	5.19	131.8
8.00	200	6.81	173.1

- a. Dimensions are for following flange offerings:
- 2"-4": ANSI Class 1500
  - 6"-8": ANSI Class 900-1500
  - DN150-200: PN160

**PRODUCT SAFETY SPECIFICATIONS**

**Pressure Safety**

Designed to withstand pressure within ANSI/ASME B16.5 Class 150, 300, 600, 900, or 1500 flange ratings, and DIN EN 1092-1, PN16, PN25, PN40, PN63, PN100, or PN160 flange ratings. See MI 019-222 for ANSI and DIN flange pressure-temperature ratings. For other flange ratings, centering spacers are provided.

**Personnel and Electrical Fire Safety**

This device is designed to be a minimum fire hazard by using low energy power and adequate insulation and separation of electrical circuits. The required standards of worldwide testing agencies such as FM, CSA, ATEX, IECEx, and OSHA have been fulfilled.

**ELECTRICAL SAFETY SPECIFICATIONS**

The Model 84C has been designed to meet the electrical safety descriptions listed below. For detailed information, or status of the testing laboratory approval/certification, contact Global Customer Service.

With intrinsically safe approvals and certifications with a 24 V dc supply, an active barrier is required.

Refer to MI 019-177 for FM and CSA Connection Diagrams; refer to MI 019-179 for ATEX and IECEx Safety Information.

**Table 8. Electrical Safety Specifications**

Agency, Types of Protection, and Area Classification	Application Conditions	Elect. Safety Design Code
<b>ATEX</b> Intrinsically safe: II 1GD; II 2D; Ex ia IIC T4 Ga Ex tb IIIC T103°C Db	Integrally mounted or remote mounted (electronics and junction box). Temperature Class T4; Ta = -40° to +80°C	AA
<b>ATEX</b> Flameproof: II 2/1 (1) GD; II 2D Ex d [ia Ga] ia IIC T4 Gb; Ex tb IIIC T85°C Db	Integrally mounted electronics. Temperature Class T4; Ta = -20° to +80°C	AD
<b>ATEX</b> Flameproof: II 2 (1) GD; II 2D Ex d [ia Ga] IIC T4 Gb; Ex tb IIIC T85°C Db	Electronics housing of remote mounted version. Temperature Class T4; Ta = -20° to +80°C	
<b>ATEX</b> Flameproof: II 1 GD; II 2D Ex ia Ga IIC T4 Gb; Ex tb IIIC T103°C Db	Flowtube junction box of remote mounted version. Temperature Class T4; Ta = -20° to +80°C	
<b>CSA</b> Intrinsically safe: Class I, II, III, Div. 1, Groups A, B, C, D, E, F, and G. Ex ia IIC T4	Temperature Class T4; Ta = -40° to +80°C	CA
<b>CSA</b> Explosion proof with Intrinsically Safe sensor connections: Class I, Div. 1, Groups A, B, C, and D; Class II, Div 1, Groups E, F, and G; Class III; [Ex ia]; T5; Ex d [ia] IIC T5 Dust-ignitionproof for Class II, Div. 1, Groups E, F, and G; Class III, Div. 1 Also Zone certified Ex d [ia] IIC.	Temperature Class T5; Ta = 60°C  Temperature Class T5; Ta = -40° to +80°C	CD
<b>CSA</b> Class I, Division 2: Class I, Div. 2, Groups A, B, C, and D; Class II, Div. 2, Groups E, F and G; Class III.	Temperature Class T4; Ta = 80°C	CN
<b>FM</b> Intrinsically safe: Class I, II, III, Div. 1, Groups A, B, C, D, E, F, G; T4 Class I Zone 0 AEx ia IIC T4	Temperature Class T4; Ta = 80°C	FA
<b>FM</b> Explosion proof with Intrinsically Safe sensor connection: Class I, Div.1, Groups B, C, and D; Dust-ignitionproof for Class II, Div. 1, Groups E, F, and G; Class III, Div. 1.	Temperature Class T5; Ta = 85°C	FD

Table 8. Electrical Safety Specifications (Continued)

Agency, Types of Protection, and Area Classification	Application Conditions	Elect. Safety Design Code
<b>FM</b> Nonincendive: Class I, Div. 2, Groups A, B, C, and D; Class II, Div. 2, Groups F and G Class III, Div. 2	Temperature Class T4; Ta = 80°C	FN
<b>INMETRO</b> Intrinsically safe	Temperature Class T4; Ta = +80°C	BA
<b>INMETRO</b> Flameproof	Temperature Class T5; Ta = +85°C	BD
<b>IECEx</b> Intrinsically safe: Ex ia IIC T4 Ga; Dust-ignitionproof Ex tD T103°C Db A20 IP66	Temperature Class T4; Ta = -40° to +80°C	EA
<b>IECEx</b> Flameproof: Ex d [ia] ia IIC T4 Gb Dust-ignitionproof Ex tD T85°C Db A20 IP66	Integrally mounted electronics. Temperature Class T4; Ta = -20° to +80°C	ED
<b>IECEx</b> Flameproof: Ex d [ia] IIC T4 Gb Dust-ignitionproof Ex tD T85°C Db A20 IP66	Electronics housing of remote mounted version. Temperature Class T4; Ta = -20° to +80°C	
<b>NEPSI</b> Intrinsically safe, Zone 0, Ex ia IIC	Temperature Class T4; Ta = -40° to +80°C	NA
<b>NEPSI</b> Flameproof, Zone 1, Ex d IIC (except acetylene)	Temperature Class T5; Ta = -20° to +85°C	ND
Unit with CE mark and PED controls and records		YY
Unit does not have CE mark; not to be installed in European Union (EU) countries		ZZ

RECOMMENDED MOUNTING ARRANGEMENTS

Table 9. Recommended Flowmeter Mounting

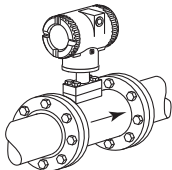
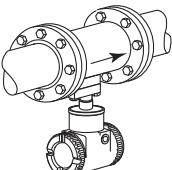
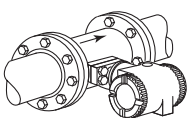
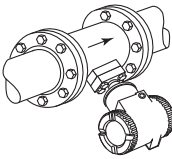
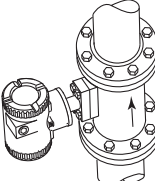
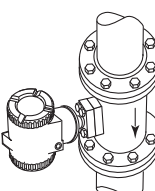
Flowmeter Mounting Arrangements		Flowmeter for Use With:			
		Liquid	Gas	Saturated Steam	Superheated Steam
	Housing Above Pipe	Yes (a)	Yes	No	Yes (b)
	Housing Below Pipe	Yes (c) (d) (e)	Yes (d)	Yes (b)	Yes (b)
	Housing to Side of Pipe	Yes	Yes	No	Yes (b)
	Housing to Side and Below Pipe	Yes (e)	Yes	No	Yes (b)
	Vertical Pipe, Flow upward	Yes	Yes	No	Yes (b)
	Vertical Pipe, Flow Downward	Yes (f)	Yes	No	Yes (b)

- a. Possibility of temporary start-up error due to trapped air.
- b. Requires adequate insulation. See MI 019-222.
- c. Best choice when errors due to start-up cannot be tolerated.
- d. Recommended only for clean fluids.
- e. Preferred for liquids with isolation valve.
- f. Not preferred; must maintain full pipe with no voids in fluid.

OPTIONAL SELECTIONS AND ACCESSORIES

**Options -B, -D, -E, -G: Cable Assembly to Remote Electronics Housing**

When selecting Code -R for a Remote Mounted Housing, a cable length must be selected. Four cable lengths are offered as follows:

Option	Cable Length
-B	20 ft (6 m)
-D	30 ft (9 m)
-E	40 ft (12 m)
-G	50 ft (15 m)

**Option -H: Cleaning for Oxygen or Chlorine Gas Service**

Process wetted parts are cleaned for oxygen or chlorine service in compliance with Compressed Gas Association's CGA-4.1 and ASTM G93. Cleaning is not offered when an isolation valve, or dual measurement or extended temperature meters are selected. Select Option -H.

**Option -A: Tamperproof and Custody Transfer**

This option is recommended if you need tamperproof sealing for housing and covers. Select Option -A.

**Option -J: Gold Plated Sensor**

This option is recommended for H<sub>2</sub> (Hydrogen) processes. Select Option -J.

**Options -L, -M, -Q: Foxboro Certificates of Conformance and Compliance**

Three material certificates are offered. Option -L provides a certificate of compliance to the specifications of the Foxboro Quality System, which conforms to ISO 9001. Option -M is a certification of material for process wetted metal (conforms to BS EN 10204 3.1). Option -Q certifies that process-wetted materials meet NACE Standards MR-0175-2003 and MR-0103-2007.

**Option -N: Certified Calibration Certificate**

A calibration and pressure test sheet come standard with each flowmeter. A certified flow calibrated K-factor and pressure test certificate is available by selecting Option -N.

**Options -F, -X: Welding Certificates – With Flanged Body Flowtubes Only**

Two certificates are available. Option -F certifies that the fabrication of flowtubes by welders is to ASME Boiler Code, Section IX. Option -X certifies that welding is per ASME Boiler Code, Section IX and Radiographic Examination.

**Option -P: Cable Connector - Hawke-Type Cable Gland**

A brass cable gland with 1/2 NPT external thread provides support for field cable. Ensure that this cable connector is qualified to meet the electrical safety specification selected. See "ELECTRICAL SAFETY SPECIFICATIONS" on page 18. Available with Electronics Housing Codes T and R only (1/2 NPT). Select Option -P.

**Option -R: Cable Connector - PG11 Cable Gland**

A PG11 cable gland with 1/2 NPT external thread provides strain relieved support for field cable. The PG11 is for cable diameters from 0.31 to 0.47 inches (8 to 12 mm). Ensure that this cable connector is qualified to meet the electrical safety specification selected. See "ELECTRICAL SAFETY SPECIFICATIONS" on page 18. Available with Electronics Housing Codes T and R only (1/2 NPT). Select Option -R.

**Option -T: Conduit Fitting**

A conduit fitting is available with Remote Mounting Code R only. It is provided when conduit is used to enclose the cable between the flowtube body and remote transmitter. Both ends of the fitting are 1/2 NPT and interconnect the conduit and transmitter at the housing and flowtube ends. Specify Option -T.

**AS Code MTS: Stainless Steel Customer Tag Accessory**

A 1.5 x 3.5 in (40 x 90 mm) stainless steel tag for customer data that does not fit on the standard plate. It is fastened to housing with wire. Accommodates 10 lines of data with 40 characters/spaces per line. Tag will also show customer's K-factor (information with flowing conditions being submitted with sales order). Specify AS Code MTS.

MODEL CODE

Description	Model
Vortex Flowmeter	84C
<b>Body Style</b>	
Flanged	F
<b>Nominal Line Size</b>	
3/4 in (DN15, 15 mm) Line Size	008
1 in (DN25, 25 mm) Line Size	010
1 1/2 in (DN40, 40 mm) Line Size	015
2 in (DN50, 50 mm) Line Size	020
3 in (DN80, 80 mm) Line Size	030
4 in (DN100, 100 mm) Line Size	040
6 in (DN150, 150 mm) Line Size	060
8 in (DN200, 200 mm) Line Size (a)	080
10 in (DN250, 250 mm) Line Size	100
12 in (DN300, 300 mm) Line Size	120
<b>Electronics Version</b>	
HART Communication Protocol	-T
Low Power with HART Communication Protocol, output fixed at 10 mA	-L
<b>Pulse Output</b>	
Standard pulse output capability	P
<b>Body, Flange, and Shedder Bar Material</b>	
316 SS and 316/304 SS:	R
▶ For line sizes 008 to 040, cast 316 SS (CF8M) body and shedder bar with 316 SS flanges	
▶ For line sizes 060 to 080, cast 316 SS (CF8M) body and shedder bar with 304 SS flanges	
304 SS:	E
▶ For line sizes 100 to 120, fabricated 304 SS body and shedder bar with 304 SS flanges	
316 SS with face-to-face lengths backward compatible with Style A Model 84 Vortex flowmeters: (b)	Y
▶ For line sizes 008 to 040, cast 316 SS (CF8M) body and shedder bar with 316 SS flanges	
(Line sizes 060 to 120 already have backward compatible face-to-face lengths)	



## MODEL CODE

## MODEL CODE (CONTINUED)

<u>Description</u>	<u>Model</u>
<b><u>End Connections and Flange Rating</u></b>	
ANSI Class 150 RF	F1
ANSI Class 300 RF	F2
ANSI Class 600 RF	F3
ANSI Class 900 RF (not available with line sizes 100 and 120)	F4
ANSI Class 1500 RF (not available with line sizes 100 and 120)	F5
ANSI Class 150 RTJ (not available with line size 008)	T1
ANSI Class 300 RTJ	T2
ANSI Class 600 RTJ	T3
ANSI Class 900 RTJ (not available with line sizes 100 and 120)	T4
ANSI Class 1500 RTJ (not available with line sizes 100 and 120)	T5
PN16 EN1092-1 Raised Face Type "D" Nut Groove (available with line sizes 060 to 120 only)	D1
PN25 EN1092-1 Raised Face Type "D" Nut Groove (available with line sizes 080 to 120 only)	D2
PN40 EN1092-1 Raised Face Type "D" Nut Groove	D3
PN63 EN1092-1 Raised Face Type "D" Nut Groove (available with line sizes 020 to 120) (c)	D6
PN100 EN1092-1 Raised Face Type "D" Nut Groove	D7
PN160 EN1092-1 Raised Face Type "D" Nut Groove (not available with line sizes 008, 100, 120)	D5
PN16 EN1092-1 Raised Face Finish Type B1 (available with line sizes 060 to 120 only)	B1
PN25 EN1092-1 Raised Face Finish Type B1 (available with line sizes 080 to 120 only)	B2
PN40 EN1092-1 Raised Face Finish Type B1	B3
PN63 EN1092-1 Raised Face Finish Type B2 (d)	B6
PN100 EN1092-1 Raised Face Finish Type B2	B7
PN160 EN1092-1 Raised Face Finish Type B2 (not available with line sizes 008, 100, 120)	B5
PN40 EN1092-1 Raised Face Finish Type F	C3
PN100 EN1092-1 Raised Face Finish Type F	C7
<b><u>Single or Dual Measurement and Isolation Manifold</u></b>	
Single Measurement; No Isolation Manifold	S
<b><u>Multivariable Selection</u></b>	
Temperature compensation only (up to 500°F/260°C maximum with Multivariable Selection T.) (e)	T
<b><u>Sensor Fill, Temperature Range, and Material (e)</u></b>	
<b><u>Standard Temperature Range (with Fill Fluid)</u></b>	
Fluorolube Fill, 0° to 200°F (-20° to +90°C) Nickel alloy CW2M (f)	D
Fluorolube Fill, 0° to 200°F (-20° to +90°C) Stainless Steel CF3M	F
Silicone Fill, 0° to 400°F (-20° to +200°C) Nickel alloy CW2M (f)	R
Silicone Fill, 0° to 400°F (-20° to +200°C) Stainless Steel CF3M	S
<b><u>Extended Temperature Range (No Fill Fluid)</u></b>	
Unfilled, 300° to 700°F (149° to 371°C) Nickel alloy CW2M (f)	A
Sensor Options A and B are rated to 500°F (260°C) maximum with Multivariable Selection T.	
Unfilled, 300° to 700°F (149° to 371°C) Stainless Steel CF3M	B
Sensor Options A and B are rated to 500°F (260°C) maximum with Multivariable Selection T.	
<b><u>Mounting and Conduit Openings for Electrical Housing</u></b>	
Aluminum Integral Top Mounted 1/2-NPT Conduit Connections	T
Aluminum Integral Top Mounted M20 Conduit Connections	V
Aluminum Remote Mounted 1/2-NPT Conduit Connections (g)	R
Aluminum Remote Mounted M20 Conduit Connections (g)	W

MODEL CODE (CONTINUED)

Description	Model
<b>Local Digital Indicator/Configurator</b>	
No Digital Indicator/Configurator	N
Full Function Digital Indicator/Configurator	J
<b>Electrical Safety (refer to Electrical Safety Specifications section for details) (h)</b>	
ATEX intrinsically safe	AA
ATEX flameproof	AD
CSA intrinsically safe	CA
CSA Division 2	CN
CSA explosion proof	CD
FM intrinsically safe	FA
FM nonincendive	FN
FM explosion proof	FD
IECEX intrinsically safe	EA
IECEX flameproof	ED
NEPSI intrinsically safe	NA
NEPSI flameproof	ND
INMETRO intrinsically safe	BA
INMETRO flameproof	BD
No Agency Electrical Certifications; with CE mark, PED Controls and Records	YY
No Agency Electrical Certifications; no CE mark; Units not to be installed in European Union (EU) countries	ZZ
<b>Optional Selections</b>	
<b>Cable Length Selection for Remote Electronics Housing</b>	
20 ft (6 m) Cable to Connect to Remote Electronics Housing	-B
30 ft (9 m) Cable to Connect to Remote Electronics Housing	-D
40 ft (12 m) Cable to Connect to Remote Electronics Housing	-E
50 ft (15 m) Cable to Connect to Remote Electronics Housing	-G
<b>Instruction Manual</b>	
Detailed Instruction Manual in hard copy format (i)	-C
<b>Foxboro Certificates of Compliance/Conformance</b>	
Standard Certificate of Compliance	-L
Foxboro Material Certification of Process Wetted Metal (Conforms to BS EN 10204 3.1.B)	-M
Process Wetted Parts Comply with NACE Standards MR-0175-2003 and MR-0103-2007	-Q
<b>Foxboro Calibration Certificate</b>	
Calibration and Pressure Test Certified Copy	-N
<b>Cable Connectors – with Electronics Housing Codes T and R only (1/2 NPT)</b>	
Hawke Cable Gland (available only with electrical safety codes YY and ZZ)	-P
PG11 Cable Gland, Trumpet Shaped (not available with explosion proof/flameproof certifications)	-R

MODEL CODE (CONTINUED)

Description	Model
<p><b>Welding Certificate (select only one option)</b>                      Welding certified to conform to ASME Boiler and Pressure Vessel Code, Section IX                      Welding certified to conform to ASME Boiler and Pressure Vessel Code, Section IX and Radiographic Examination (X-Ray) of welds</p>	<p>-F -X</p>
<p><b>Cleaning for Oxygen/Chlorine Service</b>                      Cleaning of Process Wetted Parts per Compressed Gas Association's CGA G-4.1 and ASTM G93                      - Available only with Body/Flange/Shedder Material Codes R and Y.                      - Contact Global Customer Support for availability with line sizes 100 to 120</p>	<p>-H</p>
<p><b>Tamperproof and Custody Transfer Options</b>                      Tamperproof sealing for housing and covers</p>	<p>-A</p>
<p><b>Sensor Plating</b>                      Gold Plated Sensor</p>	<p>-J</p>
<p><b>Optional Conduit Fitting</b>                      Adapter for use with 1/2 NPT conduit (Available only with Remote Mounted Housing Code R)</p>	<p>-T</p>
<p>Example: 84CF020-TPRF1STDTJYY-N</p>	

- a. For Line Size 008 with F4, F5, T4, T5, D5, B5 End Connections, Welding Certificate Option -X is included.
- b. Body, Flange, and Shedder Bar Material Selection Y is recommended only for replacement of Style A flowmeters.
- c. For Line Sizes 008, 010, and 015, select End Connection D7.
- d. For Line Sizes 008, 010, and 015, select End Connection B7.
- e. Multivariable Option T allows for up to 500°F (260°C). The temperature element of the RTD is rated only up to 500°F (260°C). Use caution when using a Vortex high temperature sensor, which may be rated to a higher temperature.
- f. Equivalent to Hastelloy® C-4C.
- g. For remote mounting, select optional cable length.
- h. The Model 84C has been designed to meet the electrical safety descriptions listed in this table. For detailed information, or status of the testing laboratory approval/certification, contact Global Customer Service.
- i. A DVD containing the full documentation set is shipped standard with the product.

DIMENSIONS – NOMINAL

84C FLANGED BODY FLOWMETER WITH INTEGRALLY MOUNTED ELECTRONICS

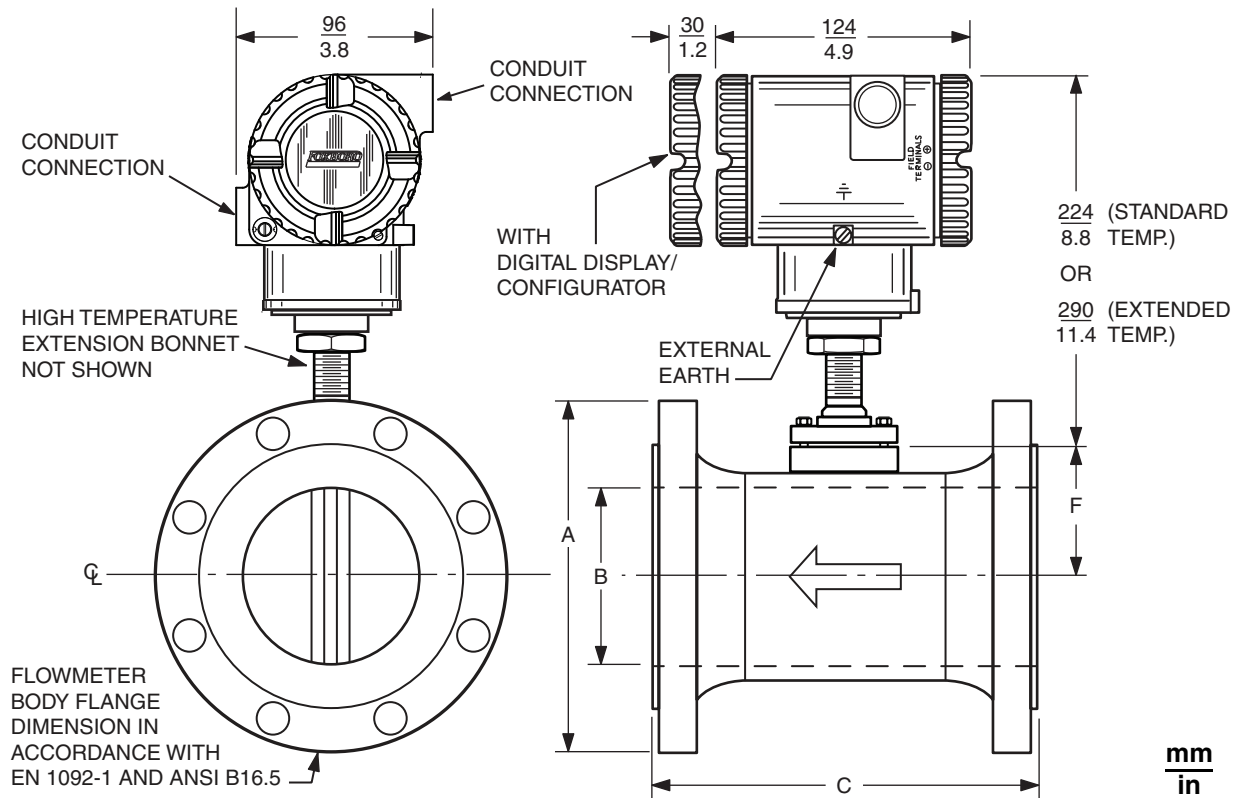

Refer to Table 10, Table 11, and Table 12 for dimensions A, B, C, and F.

REMOTELY MOUNTED ELECTRONICS HOUSING

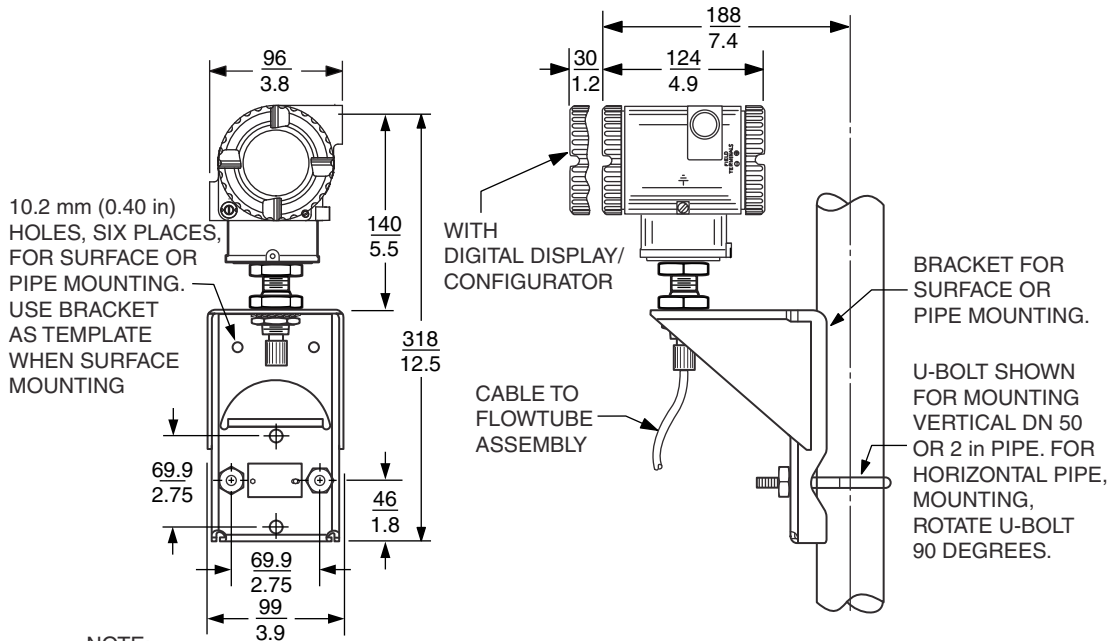

NOTE:

WHEN THE BRACKET IS USED FOR WALL MOUNTING, REPLACE U-BOLT WITH TWO (OR FOUR IF NECESSARY) 0.375 IN BOLTS OF SUFFICIENT LENGTH TO PASS THROUGH THE BRACKET AND SURFACE

INTEGRAL JUNCTION BOX AND REMOTELY MOUNTED ELECTRONICS HOUSING

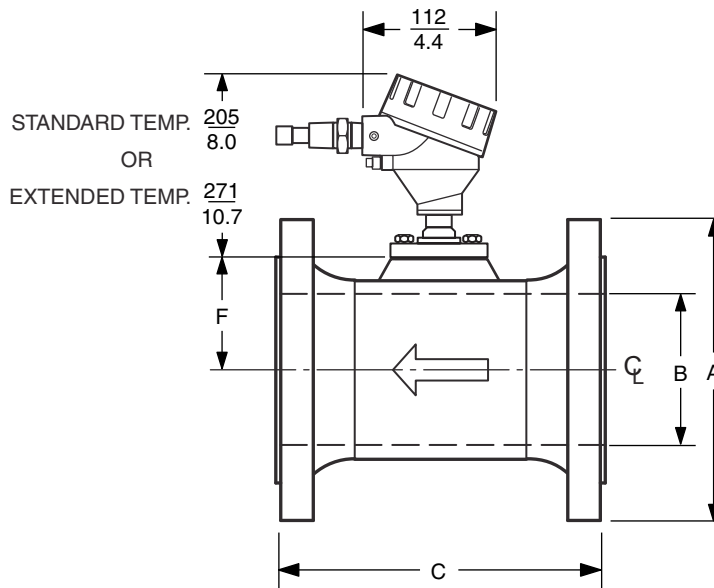

Refer to Table 10, Table 11, and Table 12 for dimensions A, B, C, and F.

### Face-to-Face Dimension “C”

Before installing your flowmeter, check its data plate to determine its style: A, B or C. The style indicator (ST) on the data plate is illustrated below.

Tables 10 and 11 provide face-to-face lengths of Model 84C flanged flowmeters with Body, Flange, and Shedder Bar Material model code selections R and E. The face-to-face lengths of these 84C flowmeters have matching face-to-face lengths as Model 84 Style B flanged flowmeters.

Table 12 provides face-to-face lengths of Model 84C flanged flowmeters with Body, Flange, and Shedder Bar Material model code selection Y. The face-to-face lengths of these 84C flowmeters have matching face-to-face lengths as Model 84 Style A flanged flowmeters. Model code selection Y should **only** be used to replace Style A flowmeters.

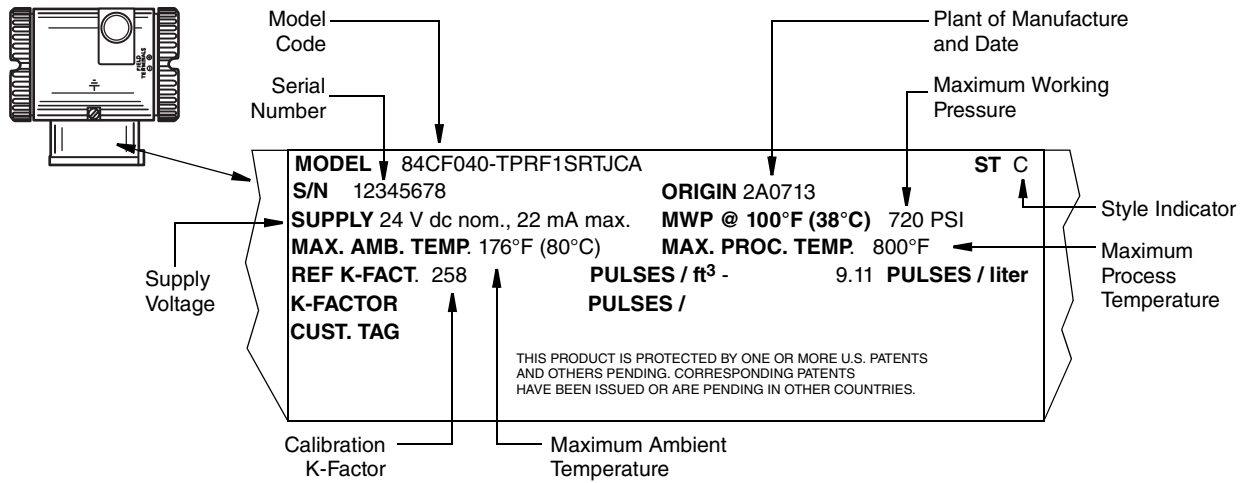

Table 10. 84C Single Measurement Configuration With ANSI Flanges and Integral Housing; Body, Flange, and Shedder Bar Material Model Code Selections R and E

Nominal Line Size	Flange Type	Dimensions in inches				
		A (O.D.)	B (I.D.)	C (a) RF	C (a) RTJ	F
3/4 in	Class 150	3.88	0.74	6.56	--	1.82
	Class 300	4.62	0.74	6.94	7.32	1.82
	Class 600	4.62	0.74	7.44	7.44	1.82
	Class 900	5.12	0.74	8.44	8.44	1.82
	Class 1500	5.12	0.74	8.44	8.44	1.82
1 in	Class 150	4.25	0.96	6.80	7.18	1.93
	Class 300	4.88	0.96	7.32	7.70	1.93
	Class 600	4.88	0.96	7.82	7.82	1.93
	Class 900	5.88	0.96	8.7	8.70	1.93
	Class 1500	5.88	0.96	8.7	8.70	1.93

Table 10. 84C Single Measurement Configuration With ANSI Flanges and Integral Housing; Body, Flange, and Shedder Bar Material Model Code Selections R and E (Continued)

Nominal Line Size	Flange Type	Dimensions in inches				
		A (O.D.)	B (I.D.)	C (a) RF	C (a) RTJ	F
1 1/2 in	Class 150	4.62	1.50	7.32	7.70	2.20
	Class 300	6.12	1.50	7.82	8.20	2.20
	Class 600	6.12	1.50	8.44	8.44	2.20
	Class 900	7.00	1.50	9.44	9.44	2.20
	Class 1500	7.00	1.50	9.44	9.44	2.20
2 in	Class 150	6.00	1.94	7.75	8.13	2.32
	Class 300	6.50	1.94	8.25	8.75	2.32
	Class 600	6.50	1.94	9.01	9.13	2.32
	Class 900	8.50	1.94	11.25	11.37	2.32
	Class 1500	8.50	1.69	11.25	11.37	2.20
3 in	Class 150	7.50	2.87	8.88	9.26	2.75
	Class 300	8.25	2.87	9.62	10.12	2.75
	Class 600	8.25	2.87	10.38	10.50	2.75
	Class 900	9.50	2.87	11.88	12.00	2.75
	Class 1500	10.50	2.63	13.12	13.25	2.62
4 in	Class 150	9.00	3.83	9.62	10.00	3.35
	Class 300	10.00	3.83	10.38	10.88	3.35
	Class 600	10.75	3.83	12.12	12.24	3.35
	Class 900	11.50	3.83	13.12	13.24	3.35
	Class 1500	12.25	3.44	13.88	14.00	3.35
6 in	Class 150	11.00	5.76	12.00	12.38	4.42
	Class 300	12.50	5.76	12.76	13.26	4.42
	Class 600	14.00	5.76	14.74	14.86	4.42
	Class 900	15.00	5.19	16.5	16.62	4.42
	Class 1500	15.50	5.19	19.00	19.25	4.42
8 in	Class 150	13.50	7.63	15.00	15.38	5.47
	Class 300	15.00	7.63	15.75	16.26	5.47
	Class 600	16.50	7.63	18.00	18.12	5.47
	Class 900	18.50	6.81	20.26	20.38	5.47
	Class 1500	19.00	6.81	24.26	24.64	5.47
10 in	Class 150	16.00	9.56	15.00	15.38	6.55
	Class 300	17.50	9.56	16.24	16.74	6.55
	Class 600	20.00	9.56	19.5	19.62	6.55
12 in	Class 150	19.00	11.37	17.00	17.38	7.55
	Class 300	20.50	11.37	18.24	18.74	7.55
	Class 600	22.00	11.37	20.74	20.76	7.55

a. Overall length "C" is  $\pm 0.250$  in ( $\pm 6.4$  mm).



Table 11. 84C Single Measurement Configuration With DIN Flanges and Integral Housing;  
Body, Flange, and Shedder Bar Material Model Code Selections R and E

Nominal Line Size	Flange Type	Dimensions in mm			
		A (O.D.)	B (I.D.)	C (a)	F
15 mm	PN 40 (b)	95.00	18.80	138.00	46.20
	PN 100	105.00	18.80	152.00	46.20
25 mm	PN 40 (b)	115.00	24.31	142.00	49.00
	PN 100	140.00	24.31	178.00	49.00
	PN 160	140.00	24.31	178.00	49.00
40 mm	PN 40 (b)	150.00	38.10	152.00	55.90
	PN 100	170.00	38.10	186.00	55.90
	PN 160	170.00	38.10	190.00	55.90
50 mm	PN 40 (b)	165.00	49.20	166.00	58.90
	PN 63	180.00	49.20	194.00	58.90
	PN 100	195.00	49.20	206.00	58.90
	PN 160	195.00	49.20	220.00	58.90
80 mm	PN 40 (b)	200.00	72.90	202.00	69.90
	PN 63	215.00	72.90	230.00	69.90
	PN 100	230.00	72.90	242.00	69.90
	PN 160	230.00	72.90	258.00	69.90
100 mm	PN 40 (b)	235.00	97.18	222.00	85.10
	PN 63	250.00	97.18	248.00	85.10
	PN 100	265.00	97.18	272.00	85.10
	PN 160	265.00	97.18	292.00	85.10
150 mm	PN 16	285.00	146.30	237.00	112.30
	PN 40 (b)	300.00	146.30	277.00	112.30
	PN 63	345.00	146.30	317.00	112.30
	PN 100	355.00	146.30	357.00	112.30
	PN 160	355.00	131.80	383.00	112.30
200 mm	PN 16	340.00	193.68	302.00	138.90
	PN 25	360.00	193.68	338.00	138.90
	PN 40	375.00	193.68	354.00	138.90
	PN 63	415.00	193.68	398.00	138.90
	PN 100	430.00	193.68	438.00	138.90
	PN 160	430.00	173.05	458.00	138.90
250 mm	PN 16	405.00	242.87	318.00	166.40
	PN 25	425.00	242.87	354.00	166.40
	PN 40	450.00	242.87	388.00	166.40
	PN 63	470.00	242.87	428.00	166.40
	PN 100	505.00	242.87	492.00	166.40

**Table 11. 84C Single Measurement Configuration With DIN Flanges and Integral Housing; Body, Flange, and Shedder Bar Material Model Code Selections R and E (Continued)**

Nominal Line Size	Flange Type	Dimensions in mm			
		A (O.D.)	B (I.D.)	C (a)	F
300 mm	PN 16	460.00	288.90	359.00	191.80
	PN 25	485.00	288.90	387.00	191.80
	PN 40	515.00	288.90	433.00	191.80
	PN 63	530.00	288.90	483.00	191.80
	PN 100	585.00	288.90	543.00	191.80

- a. Overall length “C” is  $\pm 0.250$  in ( $\pm 6.4$  mm).
- b. May be used with PN 25 mating flange.

**Table 12. 84C Single Measurement Configuration With ANSI Flanges and Integral Housing; Body, Flange, and Shedder Bar Material Model Code Selection Y; Backward Compatible with Style A (a)**

(Note: These versions should only be used when replacing a Model 84F Style A meter or for stocking purposes for Model 84F Style A meters.)					
Nominal Line Size	Flange Rating	Dimensions in inches			
		A (O.D.)	B (I.D.)	C (b)	F
3/4 in	Class 150	3.88	0.74	6.00	1.82
	Class 300	4.62	0.74	6.00	
	Class 600	4.62	0.74	6.50	
1 in	Class 150	4.25	0.96	6.50	1.93
	Class 300	4.88	0.96	6.50	
	Class 600	4.88	0.96	7.00	
1 1/2 in	Class 150	4.62	1.50	7.25	2.20
	Class 300	6.12	1.50	7.25	
	Class 600	6.12	1.50	7.88	
2 in	Class 150	6.00	1.94	7.75	2.32
	Class 300	6.50	1.94	7.75	
	Class 600	6.50	1.94	8.50	
3 in	Class 150	7.50	2.87	8.75	2.75
	Class 300	8.25	2.87	8.75	
	Class 600	8.25	2.87	9.50	
4 in	Class 150	9.00	3.83	9.50	3.35
	Class 300	10.00	3.83	9.50	
	Class 600	10.75	3.83	10.50	

- a. Style B Vortex flowmeters with ANSI flanges contain a model code option for face-to-face lengths that are backward compatible with Style A Vortex flowmeters. Style B model code selection “Y” matches Style A model code selection “S”.
- b. Overall length “C” is  $\pm 0.250$  in ( $\pm 6.4$  mm).

## ORDERING INSTRUCTIONS

1. Model Number.
2. Flow Data:
  - a. Maximum, minimum, and normal flow rate.
  - b. Fluid composition and viscosity at operating temperatures.
  - c. Fluid density or relative density (specific gravity).
  - d. Maximum, minimum, and normal operating temperatures.
  - e. Maximum, minimum, and normal operating pressures.
  - f. Mating pipe schedule.
  - g. Type and location (distance) of upstream disturbances.
3. Calibration Information (analog output only); maximum flow rate at 20 mA output.
4. Electrical Classification.
5. Optional Selections and Accessories (see "Optional Selections and Accessories" section).
6. Customer Tag Data.

## FLOWEXPERTPRO SIZING APPLICATION

FlowExpertPro.com



Mobile application



## OTHER FOXBORO PRODUCTS

The Foxboro product lines offer a broad range of measurement and instrument products, including solutions for pressure, flow, analytical, temperature, positioning, controlling, and recording. For a list of these offerings, visit our web site at:

[www.fielddevices.foxboro.com](http://www.fielddevices.foxboro.com)

**Foxboro**<sup>®</sup>  
by Schneider Electric

Invensys Systems, Inc.  
10900 Equity Drive  
Houston, TX 77041  
United States of America  
<http://www.invensys.com>

Global Customer Support  
Inside U.S.: 1-866-746-6477  
Outside U.S.: 1-508-549-2424  
Website: <http://support.ips.invensys.com>

Copyright 2015 Invensys Systems, Inc.  
All rights reserved.

Foxboro, ActiveTuning, *DirectSense*, and FlowExpertPro are trademarks of Invensys Limited, its subsidiaries, and affiliates. All other trademarks are the property of their respective owners.

Invensys is now part of Schneider Electric.

0615