

Relative and differential pressure switch type 630

Pressure range
6 ... 5500 mbar



Differential pressure, vacuum and overpressure switches of type series 630 are suitable for monitoring neutral and slightly aggressive liquids and gases. Switching element isolated from medium.

Ideal for use as flow monitor in sanitary piping/ heating installations or for level monitoring in general in process technology applications. Extremely rugged construction with high functionality due to 10/20 bar safety margin in both pressure chambers.

- High overpressure safety margin at both connections (P1 + P2) up to 10/20 bar
- Functionally simple, rugged mechanics with high operating reliability
- Also for slightly aggressive liquids and gases
- Specially economical version with switching points adjusted in the factory
- Repeatability up to $< \pm 0.4$ mbar

Technical overview

Pressure range

Relative und differential	6 ... 5500 mbar
---------------------------	-----------------

Operating conditions

Medium		Liquids and neutral gases
Temperature	NBR-based	0 ... +80 °C
	FPM	-10 ... +80 °C
	EPDM	-10 ... +80 °C
	Q (Silicone)	-40 ... +80 °C
	Ambient	+65 °C
	Storage	-40 ... +80 °C
Tolerable overload (P1 > P2)	Pressure range ≤ 200 mbar	10 bar
	Pressure range > 200 mbar	20 bar
Lowest turn-on pressure		≥ 6 mbar
Smallest switching difference		≥ 3 mbar

Materials in contact with the medium

Diaphragm	NBR based	
	EPDM	
	FPM	
	Silicone	
Case	Anodized aluminium	
	Brass	
	Brass chemically nickel plated	
Other components	X14CrMoS17	1.4104
	X5CrNi18-10	1.4301
	X10CrNi18-8	1.4310
	Steel category A2 for screws	
	Polyacetate-C, Polyamide	

Contact material / Loading

Nominal voltage, type of current	250 VAC
Nominal current for resistive loading	1 A
Nominal current for motor loading	0.5 A
Contact system	Changeover contact
Service life	Mechanically 10 ⁶ switching cycles ¹⁾

Protection standard

Without cover	IP 00
With cover (PG11) ²⁾	IP 54
With cover (PG9) ³⁾	IP 65

Repeatability

±5% of the switching point	with diaphragm NBR-based / silicone	minimum ±0.4 mbar
±10% of the switching point	with diaphragm FPM / EPDM	minimum ±0.8 mbar

Electrical connections

Screw terminals (Option)	
Tab connectors (AMP) 6.3 mm	
Cable gland PG9 / PG11	with cover

Pressure connections

Thread		G 1/8
Straight screwed connection	Zinc plated steel with NBR seal for pipe (Ø 6 mm)	G 1/8
Screwed Socket	CuZn nickel plated for tube (Ø 6 mm)	G 1/8

Mounting instructions

For switching points calibrated in the factory	Indicate installation arrangement
In case of liquid media	Connections down

Remark: By changing the mounting position the switching points also change. The adjustment ranges are in relation with the mounting position.

Weight

With aluminium base	~ 380 g
With base brass / nickel-plated brass	~ 1000 g

Packaging

Single packaging in cardboard boxes

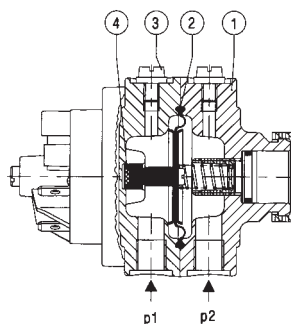

Legend to cross-section drawing

- 1 Pressure case
- 2 Diaphragm
- 3 Vent
- 4 Permanent magnet
- P1 Higher pressure / lower vacuum
- P2 Lower pressure / higher vacuum

¹⁾ Admissible switching difference has to be considered

²⁾ For installation arrangement electrical connections upward

³⁾ With O-Ring

Order code selection table		630.9	X	X	X	X	X	X
Pressure range ¹⁾	6 ... 20 mbar		1					
	15 ... 60 mbar		2					
	40 ... 200 mbar		3					
	150 ... 1000 mbar		4					
	1 ... 3 bar		5					
	2 ... 5.5 bar		6					
Contact material	AgCdO		0					
Pressure case	Anodized aluminium, black			0				
	Brass			1				
	Nickelplated brass			2				
	Anodized aluminium, black	with straight screwed connection G1/8 for pipe ø 6 mm			3			
	Brass	with straight screwed connection G1/8 for pipe ø 6 mm			4			
	Nickel plated brass	with straight screwed connection G1/8 for pipe ø 6 mm			5			
	Anodized aluminium, black	with screwed socket G½ for tube ø 6 mm			6			
	Brass	with screwed socket G½ for tube ø 6 mm			7			
	Nickel-plated brass	with screwed socket G½ for tube ø 6 mm			8			
Diaphragm material	NBR						0	
	FPM						1	
	EPDM						2	
	Q (silicone)						3	
Cover PG9 on side / Bracket	Without cover	without bracket						0
	Without cover	with bracket type A						1
	Without cover	with bracket type B						2
	With cover (plastic) (Fig.1) (PG11)	without bracket						3
	With cover (plastic) (Fig.1) (PG11)	with bracket type A						4
	With cover (plastic) (Fig.1) (PG11)	with bracket type B						5
	With spec. cover (Fig.2) (PG9)	without bracket						6
	With spec. cover (Fig.2) (PG9)	with bracket type A						7
	With spec. cover (Fig.2) (PG9)	with bracket type B						8
Switching points (optional)	Two factory set switching points	(please specify on order e.g.: W10/8mbar)						W
	One factory set switching point high	(please specify on order e.g.: R25mbar)						R
	One factory set switching point low	(please specify on order e.g.: U100mbar)						U

Setting ranges

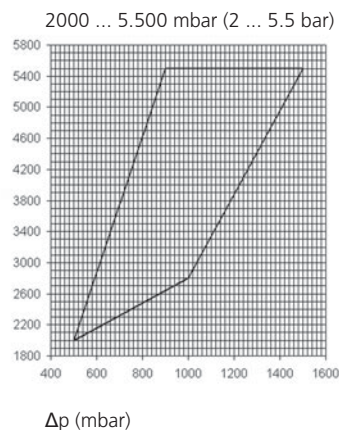
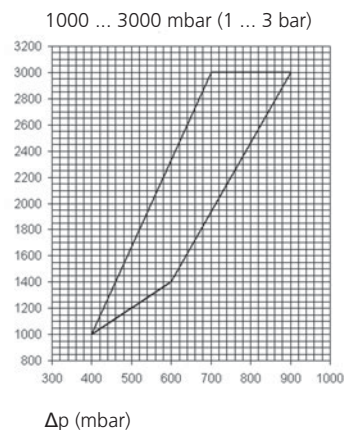
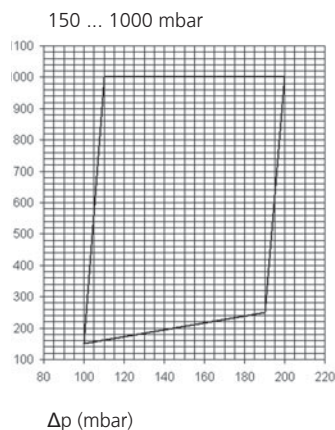
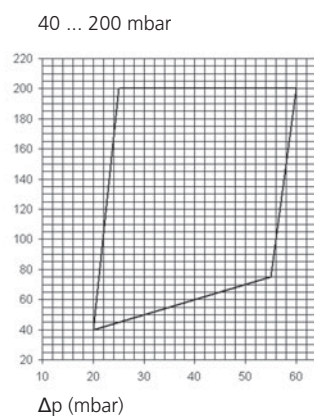
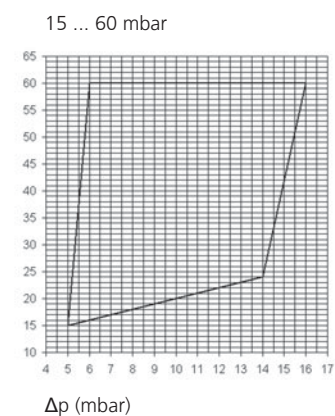
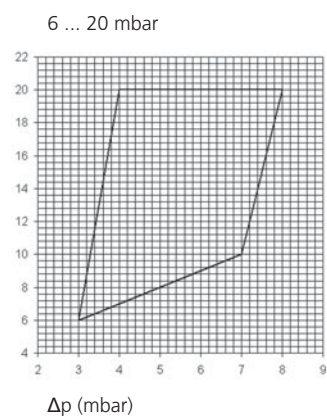

¹⁾ Other pressure range on request

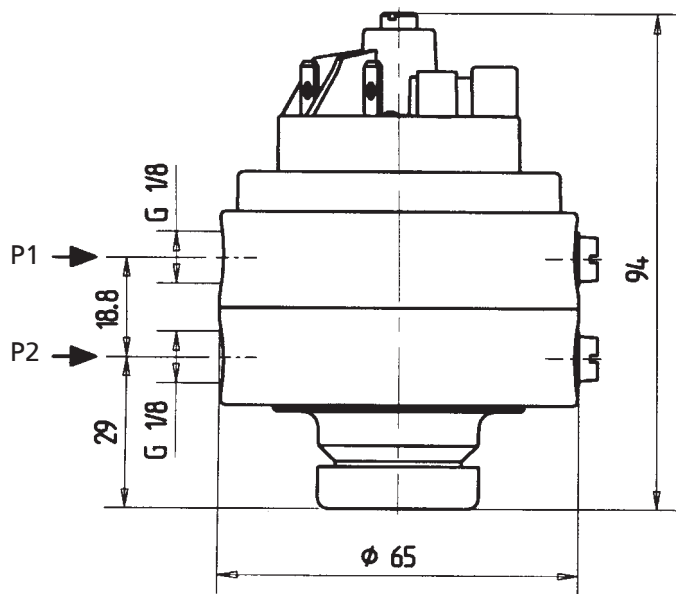
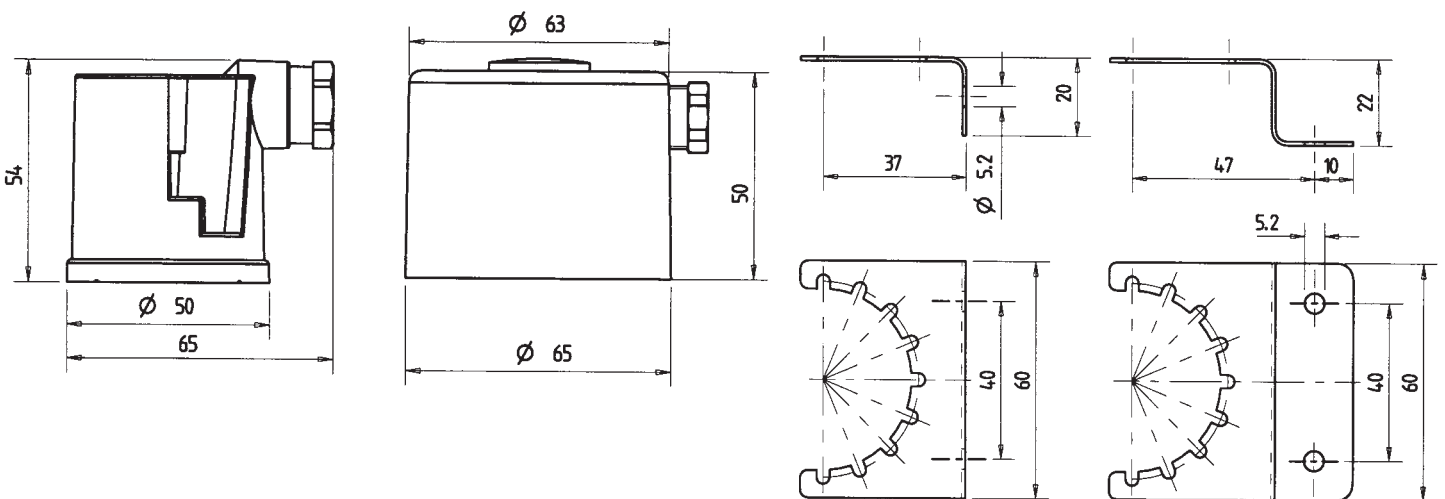

Fig. 1

Fig. 2

Type A

Type B



Straight screwed connector G 1/8

Screwed Socket G 1/8

