

Rosemount™ 389/389VP

General Purpose pH/ORP Sensors



Dependable pH/ORP measurements to solve your process needs

Rosemount 389/389VP sensors are suitable for use in a wide variety of applications. Reliably measure pH or Oxidation/Reduction Potential of aqueous solutions in pipelines, open tanks, and ponds. Rosemount 389/389VP sensors are ideal for use in process solutions containing poisoning ions.

ROSEMOUNT™



Overview



Reliability Meets Robustness

- A triple junction reference prolongs sensor life and protects against poisoning ions such as ammonia, chlorine, cyanides, and sulfides.
- Enhanced performance and increased life with cracking resistant glass.
- Available with a glass electrode option for high pH applications.
- Superior chemical resistance provided by a rugged Tefzel body with Viton O-rings.

Ease of Installation

- The molded sensor body features 1 in. MNPT front and rear facing process connections for insertion, submersion, and flow-through applications.
- Variopol (VP6) cable connection option, for quick cable-to-sensor release, eliminates cable twisting (389VP).

Maintenance Made Simple

- Automatic recognition of pH sensors by Rosemount transmitters: 56, 1056, 1057, and 1066 with integral SMART preamplifier.
- pH calibration data is stored which allows sensors to be calibrated in advance for “Plug and Play” installations in the field.

Contents

Overview	2	Product Certifications	7
Ordering Information	3	Dimensional Drawings	8
Specifications	5	Accessories	14

Ordering Information

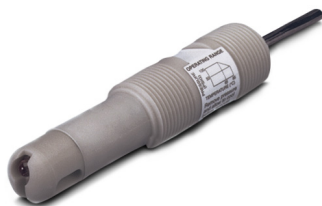

The Rosemount 389 and 389VP General Purpose pH/ORP Sensors are housed in a molded Tefzel body with 1 in. MNPT forward and rear facing threads suitable for insertion, submersion, or flow through installation. The sensors can be configured with a general purpose pH, high pH, or platinum ORP electrode. Rosemount 389/389VP sensors are offered with SMART preamplifiers for pH measurements and standard integral preamplifiers for ORP measurements. These sensors may be configured without a preamplifier but must be used with a remote preamplifier (j-box or transmitter). Automatic temperature compensation is standard. Sensors are available with either an integral cable connection (389) or Variopol (VP6) connector (389VP). Variopol cables sold separately (see [Accessories](#)).

Table 1. Rosemount 389 pH/ORP Sensor ordering information

Model	Sensor Type
389	pH/ORP Sensor
Preamplifier/Cable	
01	Integral Preamplifier, 25 ft Cable ⁽¹⁾
02	No Preamplifier, 15 ft Cable
Combination Electrode	
10	pH - GPLR Glass
11	pH - High pH Glass
12	ORP
Transmitter/TC Compatibility	
50	1181, 1050, 1060 (code -01 or -02)
54	1054A/B, 81, 2081 (code -01 or -02); for 54, 56, 1055, 1056, 1057, 1066, 5081, 6081, XMT (code -02 only)
55	54, 56, 1055, 1056, 1057, 5081, 6081, and XMT (code -01 only)
Optional	
_	No Selection
62	Cable without BNC for Models: 54, 54, 1055, 1056, 1057, 1066, 5081, 6081, XMT (codes -02 and -54 only)
Typical Model Number: 389-02-10-54-62	

1. Preamplifier is SMART if selected with pH electrode and option 55 only. Preamplifier is standard for ORP electrodes and for options 50 and 54.

Table 2. Rosemount 389VP pH/ORP Sensor ordering information

Model	Sensor Type
389VP	pH/ORP Sensor
Combination Electrode	
10	pH - GPLR Glass
11	pH - High pH Glass
12	ORP
Transmitter/TC Compatibility	
50	1181, 1050, 1060 (code -01 or -02)
54	1054A/B, 81, 2081 (code -01 or -02); for 54, 56, 1055, 1056, 1057, 1066, 5081, 6081, XMT (code -02 only)
55	54, 56, 1055, 1056, 1057, 5081, 6081, and XMT (code -01 only)
Preamplifier Option	
_	No Preamplifier
70	SMART Preamplifier ⁽¹⁾
Typical Model Number: 389VP-10-55-70	

1. Only available with -10, -11, and -55 options.

Specifications

Table 3. Percent Linearity Over pH Range

pH Range	GPLR Glass (-10)	High pH Glass (-11)
0 to 2 pH	94%	94%
2 to 12 pH	99%	97%
12 to 13 pH	97%	98%
13 to 14 pH	92%	98%

Table 4. Rosemount 389/389VP pH/ORP Sensor specification

Measurement Range	
pH	0 to 14
ORP	-1500 to +1500 mV
Temperature Range	
0 to 85 °C (32 to 185 °F)	
Automatic temperature compensation: 0 to 85 °C (32 to 185 °F)	
Maximum Pressure	
100 psig (790 kPa [abs]) at 65 °C (150 °F) – see Figure 1	
Materials of Construction	
Sensor Body	Tefzel
pH Electrode	Glass
ORP Electrode	Platinum
Junction	Ceramic
O-ring	Viton
Process Connections	
Front Facing	1 in. MNPT
Rear Facing	1 in. MNPT
Cable	
389	Integral Preamplifier – 25 ft (7.8 m); No Preamplifier – 15 ft (4.6 m)
389VP	Use 24281-XX, 2.5 ft (0.8 m) to 100 ft (31m) (see Accessories)
Weight/Shipping Weight	
0.45 kg/0.9 kg (1 lb/2 lbs)	

Figure 1. Pressure/temperature operating range for Rosemount 389/389VP

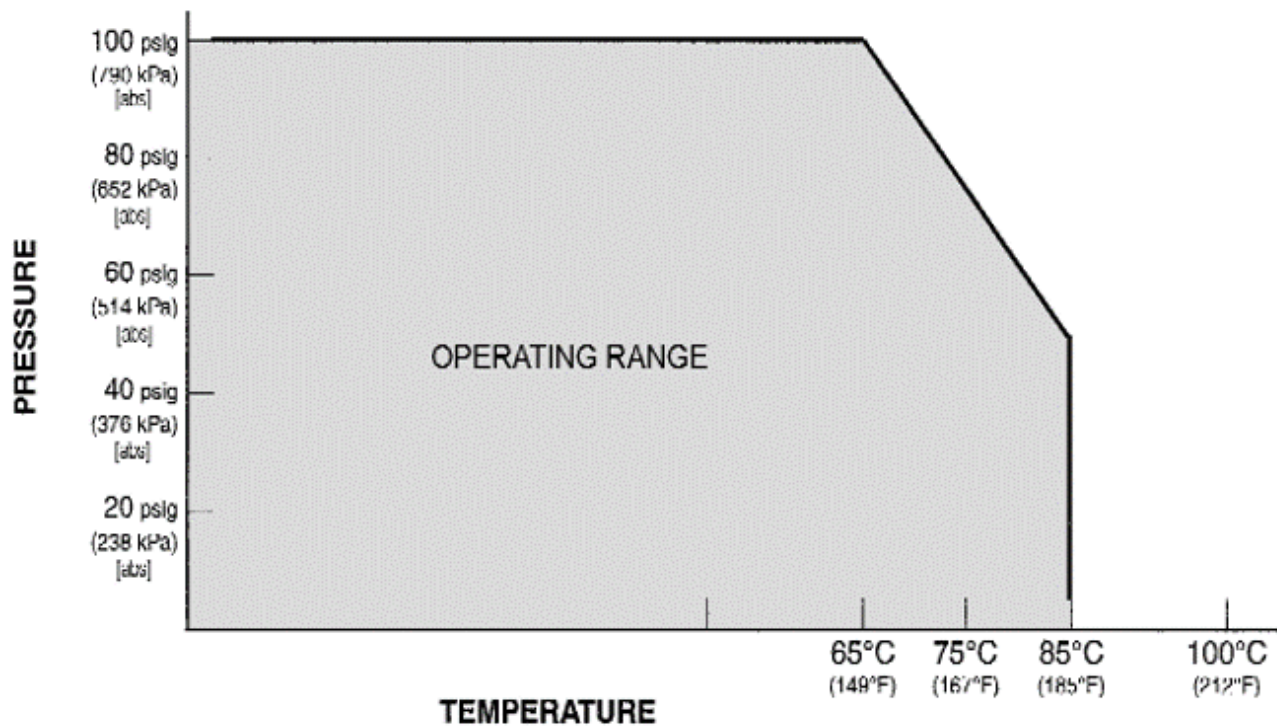

Product Certifications

IECEX

Sensors without preamp (pH and ORP) – Ex ia IIC T4 Ga (-20°C ≤ Ta ≤ +60°C)

Sensors with SMART preamp (pH only) – Ex ia IIC T4 Ga (-20°C ≤ Ta ≤ +60°C)

Sensors with standard preamp (ORP only) – Ex ia IIC T4 Ga (-20°C ≤ Ta ≤ +80°C) or Ex ia IIC T5 Ga (-20°C ≤ Ta ≤ +40°C)

Per standards IEC60079-0 : 2011, IEC 60079-11 : 2011

ATEX

Sensors without preamp (pH and ORP) –  II 1 G Ex ia IIC T4 Ga (-20°C ≤ Ta ≤ +60°C)

Sensors with SMART preamp (pH only) –  II 1 G Ex ia IIC T4 Ga (-20°C ≤ Ta ≤ +60°C)

Sensors with standard preamp (ORP only) –  II 1 G Ex ia IIC T4 Ga (-20°C ≤ Ta ≤ +80°C) or  II 1 G Ex ia IIC T5 Ga (-20°C ≤ Ta ≤ +40°C)

Per standards EN 60079-0: 2012+A11:2013, EN 60079-11:2012

FM

See online FM Certificate of Compliance for applicable sensor options:

Intrinsically Safe for use in Class I, II, and III, Division 1, Groups A, B, C, D, E, F, and G; Temperature Class T6 Ta = -20°C to +60°C

Intrinsically Safe for use in Class I, Zone 0, AEx ia IIC T6 Ta = -20°C to +60°C

Nonincendive for use in Class I, Division 2, Groups A, B, C, and D; Temperature Class T6 Ta = -20°C to +60°C

Suitable for use in Class II and III, Division 2, Groups E, F, and G; Temperature Class T6 Ta = -20°C to +60°C Hazardous (Classified) Locations IS/I,II,III/1/ABCDEFGH/T6 Ta = 60°C - 1400332; Entity; I/O/AEx ia IIC/T6 Ta = 60°C - 1400332; Entity; NI/I/2/ABCD/T6 Ta = 60°C; S/II,III/2/EFG/T6 Ta = 60°C; Entity Parameters

Per standards 3600:1998, 3610:2010, 3611:2004, 3810:2005

CSA

See online CSA Certificate of Compliance for applicable sensor options

Intrinsically Safe:

Class I, Division 1, Groups ABCD; Class II, Division 1, Groups EFG; Class III; Class I, Division 2, Groups ABCD; Ambient temperature rating -20°C to +60°C; Ex ia IIC; T6

Intrinsically Safe and Non-Incendive:

Class I, Division 1, Groups ABCD; Class II, Division 1, Groups EFG; Class III; Class I, Division 2, Groups ABCD; Ex ia IIC; T6; Ambient temperature rating -20°C to +60°C: (Simple Apparatus)

Per standards C22.2 No. 0-10, C22.2 No. 0.4-M2004, C22.2 No. 94-M1991, C22.2 No. 142 – M1987, C22.2 No. 157 – M1992, CAN/CSA E60079-0:07, CAN/CSA E60079 - 11:02, UL50 11th Ed, UL508 17th Ed, UL913 7th Ed, UL 60079-0: 2005, UL 60079-11: 2002

Dimensional Drawings

Figure 2. Rosemount 389 with integral cable connection dimensional drawing

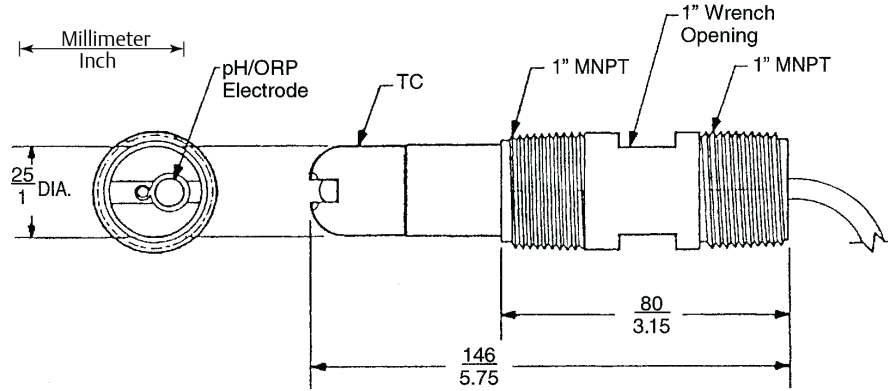

Figure 3. Rosemount 389VP with Variopole cable connection dimensional drawing

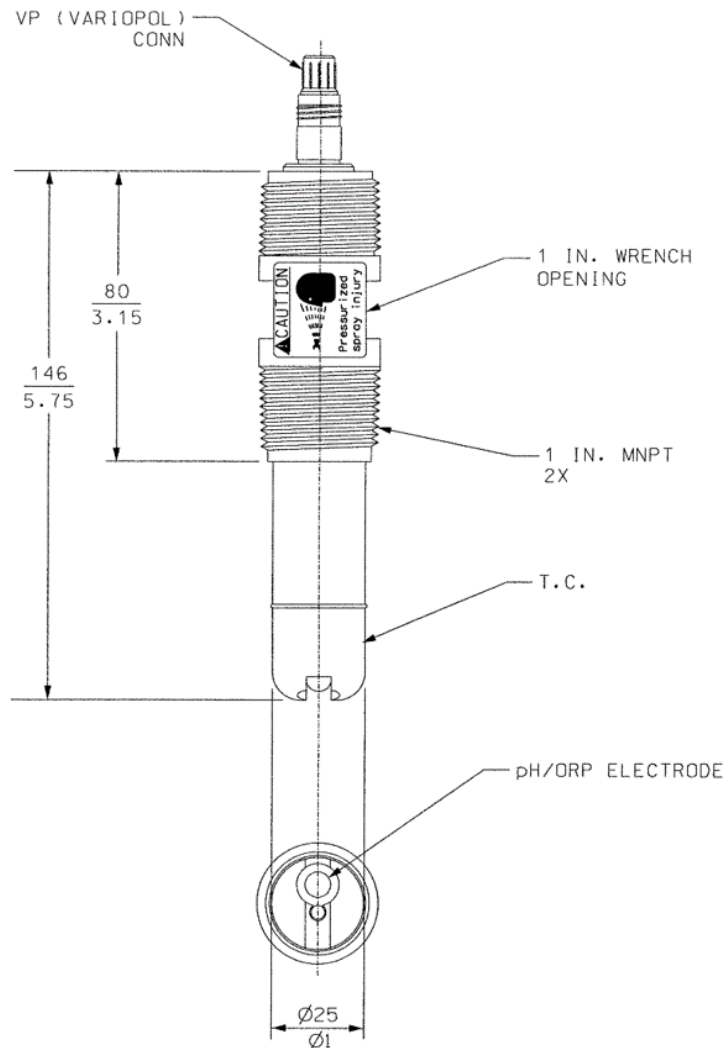

Figure 4. Flow through and insertion installations

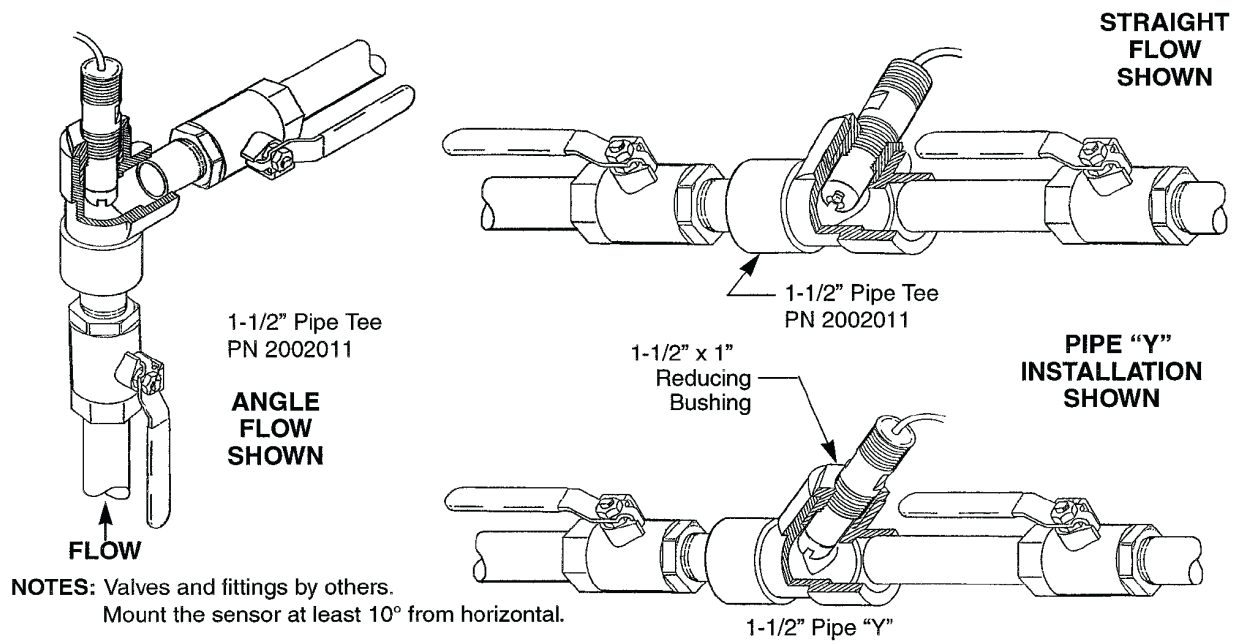

Figure 5. VP8 cable, instrument end

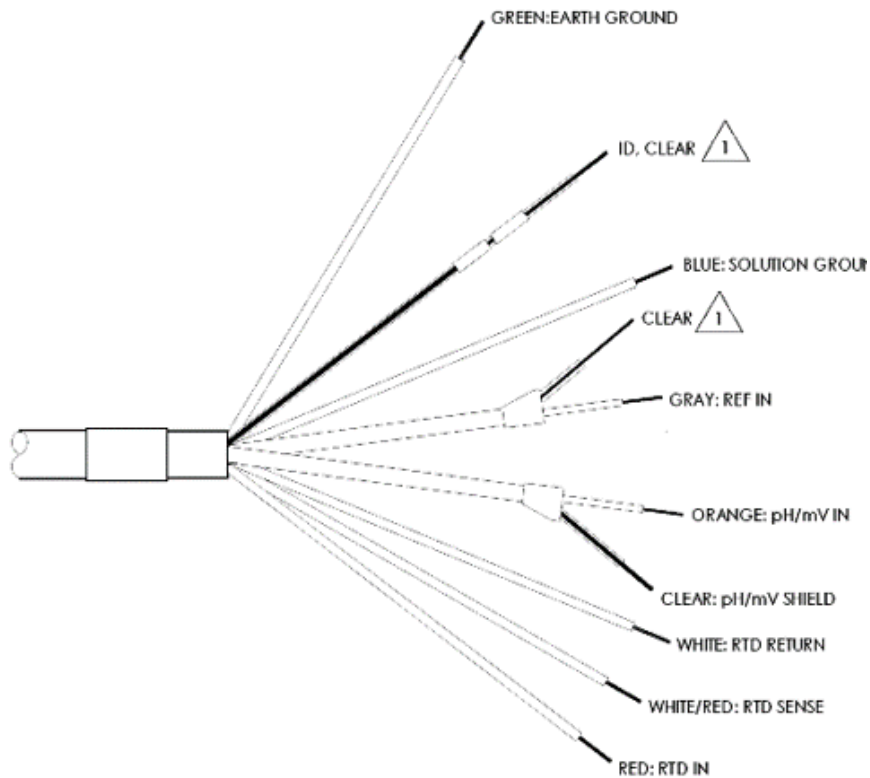

Figure 6. VP8 cable, sensor end

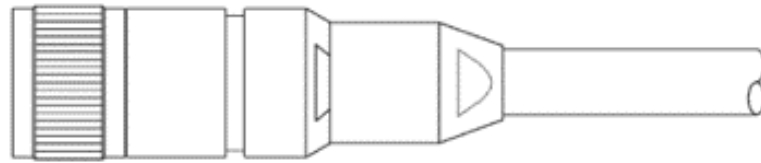
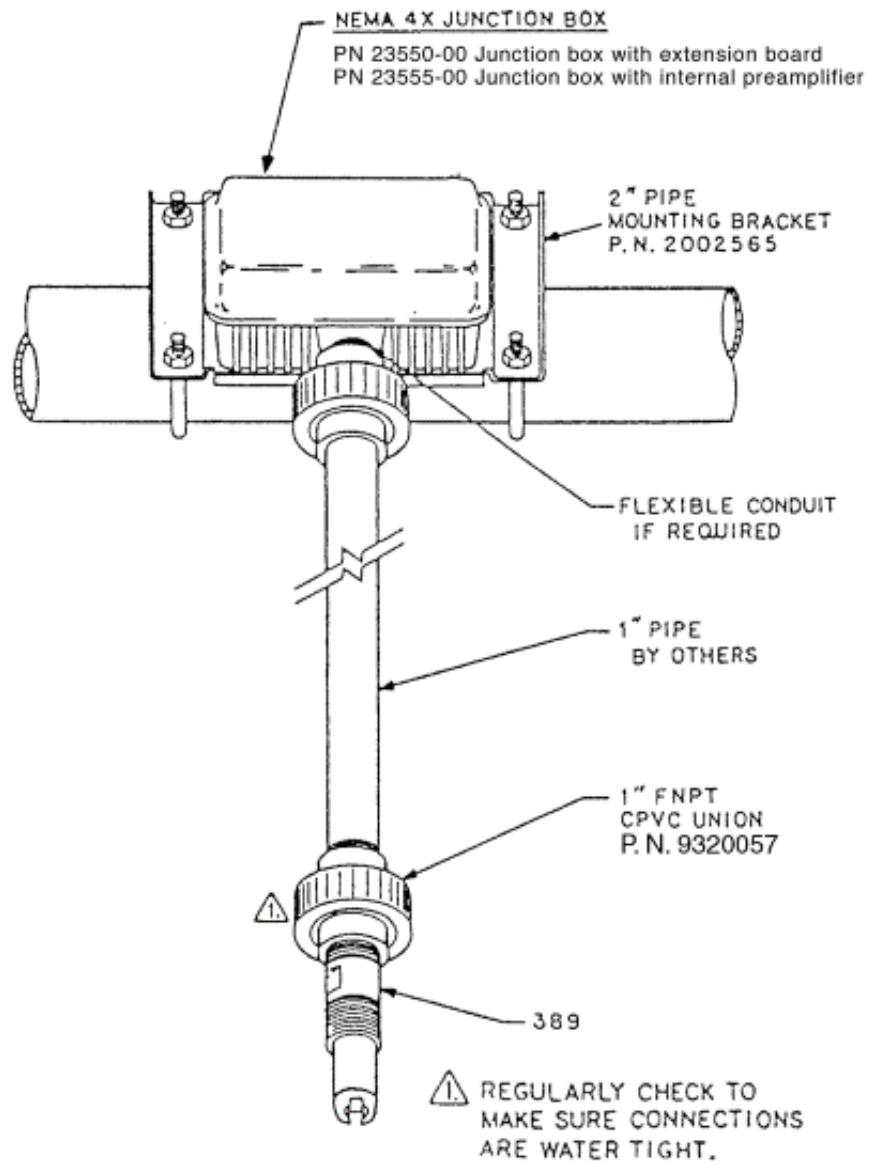

Figure 7. Submersion installation - Junction box and pipe mounting accessory



NOTES: UNLESS OTHERWISE SPECIFIED

Figure 8. Submersion installation - Handrail mounting accessory (PN 11275-01)

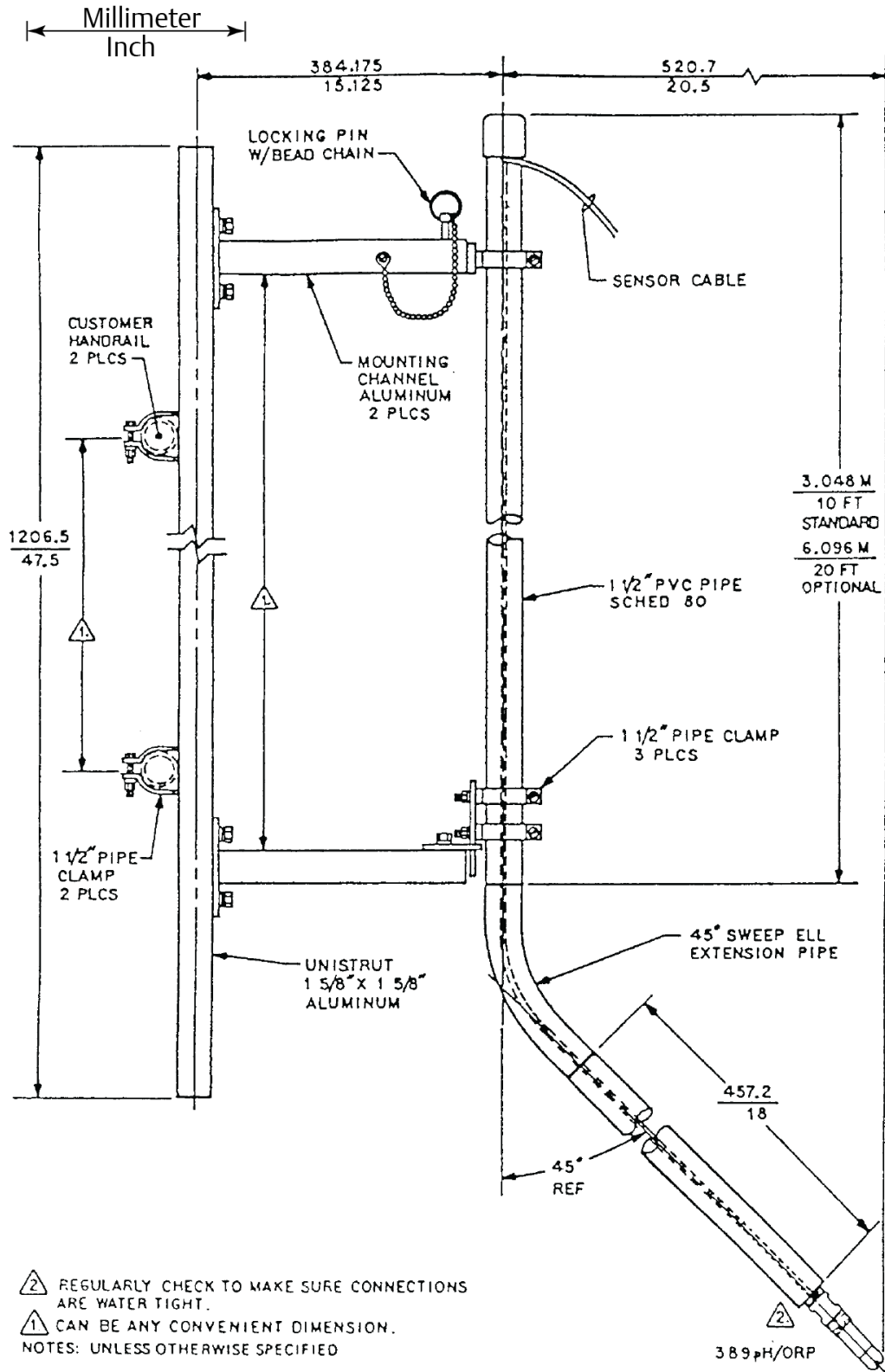
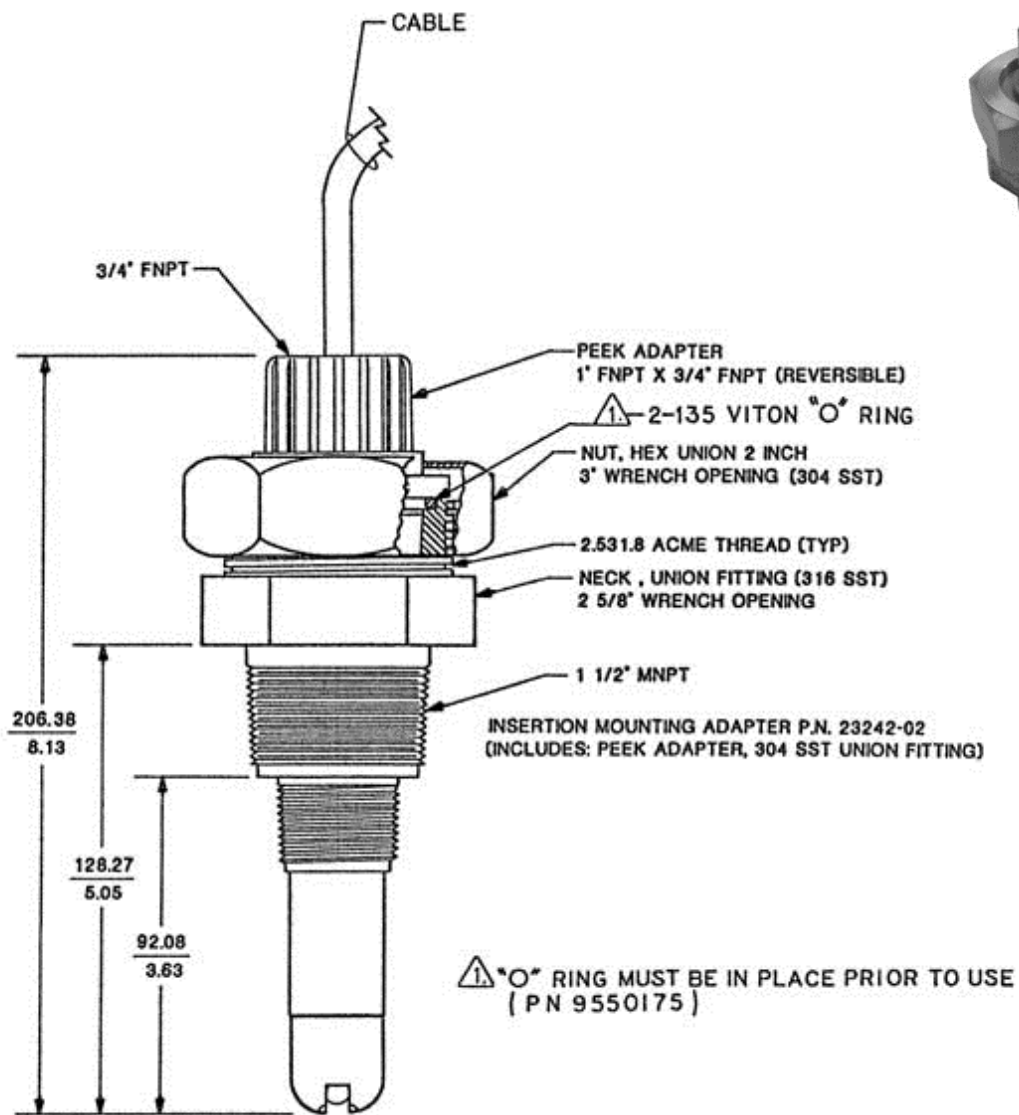
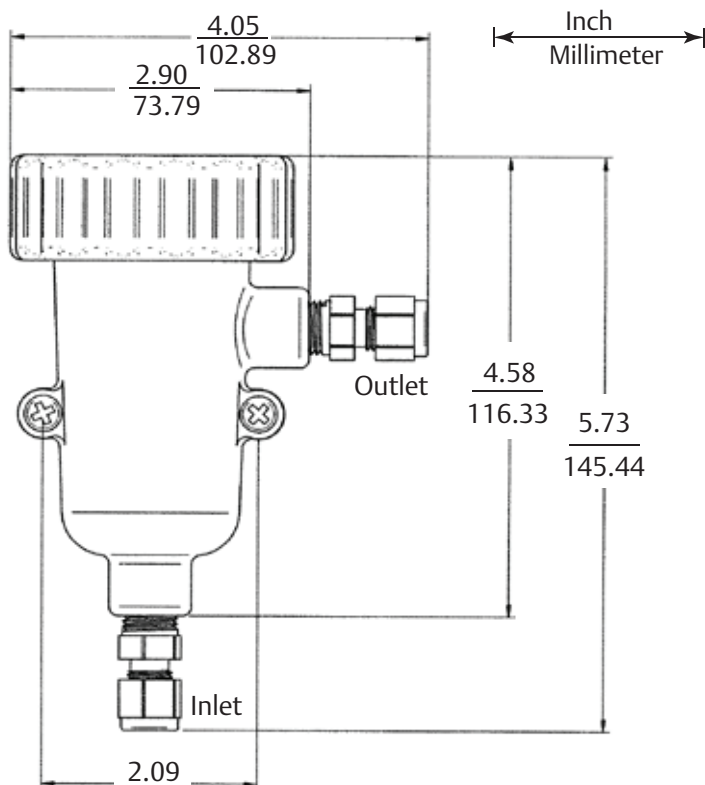

Figure 9. Rosemount 389 with insertion adapter (PN 23242-02)



The insertion adapter mounts the sensor into a 1½ in. NPT process pipe. Unscrewing the hex nut allows easy sensor removal without twisting the sensor cable.

Figure 10. Low flow cell (PN 24091-00)



Inlet and outlet connections are stainless steel and take ¼-in. OD tubing. Flow cell is polycarbonate with ¼-in. FNPT fittings.

Table 5. Low flow cell specifications (PN 24091-00)

Wetted Materials	
Body and Nut	Polyester/Polycarbonate
Fittings	316 SST
Seals	Silicone
Flow Cell Ratings	
Temperature	32 to 158 °F (0 to 70 °C)
Maximum Pressure	90 psig (721 kPa [abs])
Flow Rate	2 to 5 GPH (7.6 to 18.9 LPH)
Sensor Threaded Connection	
1 in. NPT Adapter	

Accessories

Table 6. Rosemount 389/389VP pH/ORP Sensor accessories information

Part number	Description
11275-01	Handrail Mounting Assembly
12707-00	Jet Spray Cleaner
2002011	CPVC In-Line Tee, 1.5 in. Size, 1.0 in. Threaded Process Connection Ends
915240-03	PVC In-Line Tee, 2.0 in. Size, ¾ in. Threaded Process Connection Ends
915240-04	PVC In-Line Tee, 2.0 in. Size, 1.0 in. Threaded Process Connection Ends
915240-05	PVC In-Line Tee, 2.0 in. Size, 1.5 in. Threaded Process Connection Ends
23242-02	Insertion Mounting Adapter, 1.5 in. MNPT Process Connection, 1 in. x ¾ in. FPT Sensor Adapter/Union Thread Size
33081-00	PEEK Adapter Insert, 1 x ¾ in., for 23242-02
23646-01	11-Conductor Extension Cable, Shielded and Prepped (for use with Remote Junction Box)
9200273	11-Conductor Extension Cable, Shielded and Unprepped (for use with Remote Junction Box)
24091-00	Low Flow Cell, 1 in. Sensor Threaded Connection, ¼ in. Process Connection
23555-00	Weatherproof Junction Box, with Preamplifier
2002565	Mounting Bracket Kit
9210012	pH 4.01 Buffer Solution, 16 oz
9210013	pH 6.86 Buffer Solution, 16 oz
9210014	pH 9.18 Buffer Solution, 16 oz
R508-8OZ	475 mV ORP Standard Solution, 8 oz
9320057	PVC Union Adapter, 1 in. FNPT
24281-00	15 ft. VP8 Cable
24281-01	25 ft. VP8 Cable
24281-02	2.5 ft. VP8 Cable
24281-03	50 ft. VP8 Cable
24281-04	100 ft. VP8 Cable
24281-05	4 ft. VP8 Cable
24281-06	10 ft. VP8 Cable
24281-07	20 ft. VP8 Cable
24281-08	30 ft. VP8 Cable