

PULSE VALVES

single stage, remote pilot
threaded body or compression fitting
3/4 to 1 1/2

FEATURES

- The diaphragm pulse valves are especially designed for dust collector service applications, combining high flow, long life and extremely fast opening and closing to produce reliable and economical operation
- The high flow, angle type bodies in combination with the special main diaphragm assemblies give the unique operating features required for dust collector service applications
- Integral compression fittings for fast, easy, secure installation
- Valves can be supplied according to ATEX Directive 2014/34/EU for non-electrical equipment
- The valves satisfy all relevant EC directives

GENERAL

Differential pressure (PS) 0,35 - 8,5 bar [1 bar = 100kPa]

Ambient temperature range -20 to +85°C

fluids (*)	temperature range (TS)	diaphragm (*)
air	-40 to +85 °C	TPE (3/4 and 1)
	-20 to +85 °C	CR (1 1/2)
	-20 to +120 °C	FPM

MATERIALS IN CONTACT WITH FLUID

(*) Ensure that the compatibility of the fluids in contact with the materials is verified

Body	Aluminium
Spring	Stainless steel
Diaphragm	TPE (thermoplastic polyester elastomer or CR (chloroprene) or FPM (fluoroelastomer)

PILOT SOLENOID VALVES (2/2 NC function)

main pulse valve catalogue number	remote pilot connection	recommended executions		
		orifice size (mm)	manifold pilot valves in a box (IP 65)	single pilot valves (IP20)
G353A041	G 1/8	3,6	pilot box series 110 2 to 12 pilots 1/8	series 257
G353-055				
G353A042				
G353-056				
G353A045	G 1/4	5,6	pilot box series C20 4 to 6 valves 1/4	series 262
G353-066				

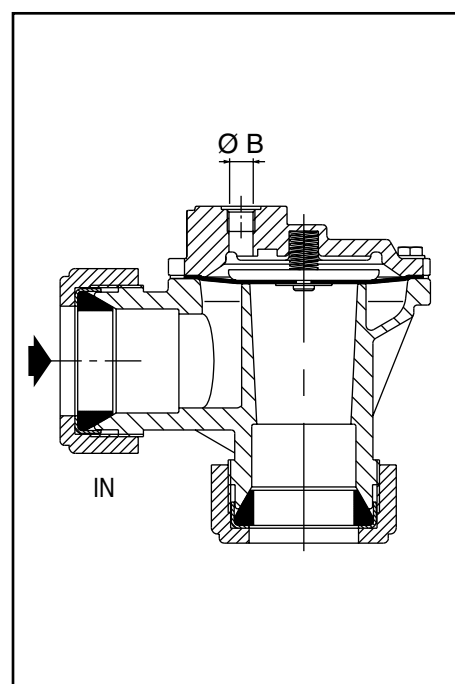

Figure shows catalogue number G353-066

SPECIFICATIONS

pipe size	remote pilot connection	orifice size (mm)	flow coefficient Kv		operating pressure differential (bar)		catalogue number	FPM
					min.	max. (PS) air (*)		
G	Ø B	(mm)	(m³/h)	(l/min)		~/=	aluminium ⁽¹⁾	
G - threaded pipe connection								
3/4	G 1/8	24	14	233	0,35	8,5	G353A041 (GD)	V
1	G 1/8	27	17	283	0,35	8,5	G353A042 (GD)	V
1 1/2	G 1/4	50	46	768	0,35	8,5	G353A045 (GD) ⁽²⁾	V
Ø - Compression fitting pipe connection								
3/4	G 1/8	24	14	233	0,35	8,5	G353-055 (GD)	V
1	G 1/8	27	17	283	0,35	8,5	G353-056 (GD)	V
1 1/2	G 1/4	50	43	717	0,35	8,5	G353-066 (GD) ⁽²⁾	V

(1) Suffix GD for ATEX II2G/D (2) Contains spring above the main diaphragm

OPTIONS

- Valves can also be supplied with FPM (fluoroelastomer) diaphragms and seals. Use the appropriate optional suffix letter for identification
- Sequential controller for pilot solenoid valves
- Pilot boxes containing 2 to 12 pilot solenoid valves
- Pilot solenoid valves can be equipped with explosionproof solenoids for hazardous locations according to “ATEX” and national standards

INSTALLATION

- The valves can be mounted in any position without affecting operation
- Threaded pipe connection is G (ISO 228/1) or compression fitting
- When connecting piping or tubing to the G1/8 connection in the valve bonnet, the remote ASCO pilot valve should be mounted as close as possible to the main pulse valve. Connection tubing lengths of 3 meter or less have little effect on the pulse response. Installations with over 3 meter of tubing must be tested under actual operating conditions. Tubing with Ø 6 mm O.D. is recommended for all installations
- For compression fitting types tightness is achieved by the compressed gasket on the blow tube
- Other pipe threads are available on request
- Installation/maintenance instructions are included with each valve
- Spare parts kits and replacement coils are available

DIMENSIONS (mm), WEIGHT (kg)

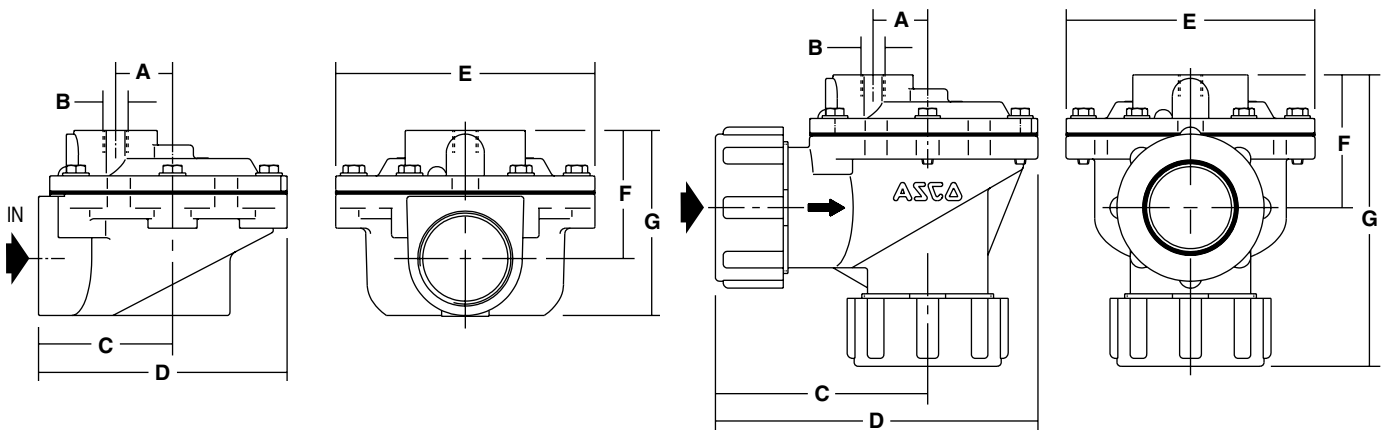

Fig. 1: Threaded pipe connection - aluminium

Fig. 2: Compression type fitting - aluminium

catalogue number	A	B	C	D	E	F	G	weight	(C)
G353A041 (GD)	-	G 1/8	51	89	75	41	65	0,45	Fig. 1
G353A042 (GD)	-	G 1/8	51	89	75	41	64	0,4	Fig. 1
G353A045 (GD)	30	G 1/4	71	130	136	71	98	1	Fig. 1
G353-055 (GD)	-	G 1/8	88	125	75	47	109	0,58	Fig. 2
G353-056 (GD)	-	G 1/8	88	124	75	47	129	0,61	Fig. 2
G353-066 (GD)	30	G 1/4	117	177	136	73	161	1,33	Fig. 2

(C) Construction type

SPARE PARTS KITS

catalogue number	spare parts kit no. ~/=
G353A041 (GD)	C113443
G353A042 (GD)	
G353-055 (GD)	
G353-056 (GD)	
G353A045 (GD)	C113825
G353-066 (GD)	