

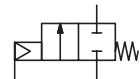

VALVES

pressure operated
bronze body
with flanges PN16, DN 25 to 50

NC



NO

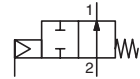

2/2
Series
T290

FEATURES

- Remote-controlled valves with disc for industrial fluids
- Anti-waterhammer design (fluid entry under the disc)
- Vacuum operation up to 10^{-2} mbar
- Wide range of piston-type operators (63 - 90 - 125 mm dia.) rotatable through 360°, for maximum performance at different minimum pilot pressures
- High performance, maintenance-free stuffing box
- The valves satisfy Pressure Equipment Directive 2014/68/EU, category 1 (DN > 25) or article 4.3 (DN 25)
- The valves in conformity with IEC 61508 Standard (2010 route 2_H version) certified with integrity levels: SIL 2 for HFT = 0

GENERAL

Differential pressure	See «SPECIFICATIONS» [1 bar = 100 kPa]
Maximum allowable pressure	16 bar
Ambient temperature range	-10°C to +60°C
Maximum viscosity	600 cSt (mm ² /s)
Pilot fluid	Filtered air or water ⁽¹⁾
Max. pilot pressure	10 bar
Min. pilot pressure	See below and following page
Pilot fluid temperature	-10°C to +60°C
Response time	See page 7 (www.asco.com)

fluids (*)	temperature range	disc seal (*)
air and gas groups 1 & 2 water, oil, liquids groups 1 & 2 and steam	- 10°C to + 184°C	PTFE

CONSTRUCTION

Connection Flange type 21 (ISO 7005) - PN 16
Facing Type A

MATERIALS IN CONTACT WITH FLUID

(*) Ensure that the compatibility of the fluids in contact with the materials is verified

Valve body	Bronze
Stuffing box housing	Brass
Stem	Stainless steel
Disc	Brass
Stuffing box packing	PTFE chevrons
Wiper seal	FPM
Disc seal	PTFE
Valve body seal	PTFE

OTHER MATERIALS

Operator Glass fibre filled PA
Optical position indicator PA 12, supplied standard on valves with 63, 90 and 125 mm operators

⁽¹⁾ For dia. 63, 90 and 125 mm operators: At service fluid temperatures inside the valve body above 100°C, it is prohibited to pilot the valve with water.

SPECIFICATIONS

DN	orifice size (mm)	flow coefficient Kv (m ³ /h) (l/min)		pilot pressure (bar) min. max.		operating pressure differential (bar)			operator diameter (mm)	catalogue number	
						min.	max.				
							air inert gas (*)	water, oil, liquids (*)			steam (*) (≤184°C)
NC - Normally closed, entry under the disc ⁽¹⁾											
25	25	12	200	4	10	0	10	10	10	63	T290A010
							16	16	10	90	T290A011
				2,5	10	0	6	6	6	63	T290A008
							12	12	10	90	T290A009
32	32	18	300	4	10	0	6	6	6	63	T290A016
							12	12	10	90	T290A017
				2,5	10	0	7	7	7	90	T290A015
							4	4	4	63	T290A020
40	40	32	530	4	10	0	8	8	8	90	T290A021
							16	16	10	125	T290A482
		35	583	2,5	10	0	10	10	10	125	T290A481
							2,5	2,5	2,5	63	T290A024
50	50	39	650	4	10	0	6	6	6	90	T290A025
							10	10	10	125	T290A485
		44	733	2,5	10	0	5	5	5	125	T290A484
							NO - Normally open, entry under the disc				
25	25	12	200	II (*)	10	0	16	16	10	63	T290A028
				III (*)	10	0	16	16	10	90	T290A029
32	32	18	300	II (*)	10	0	16	16	10	63	T290A030
		19	317	IV (*)	10	0	16	16	10	125	T290A643

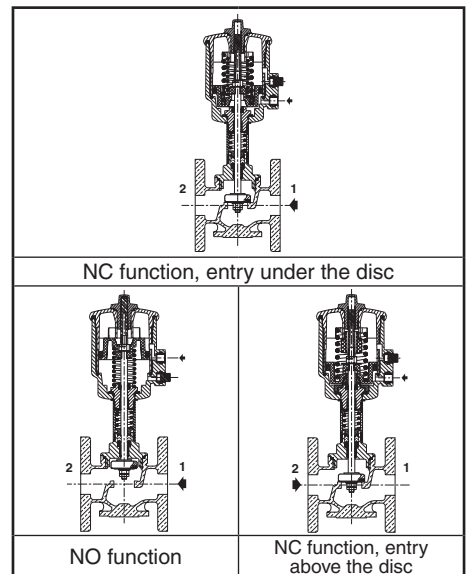

SPECIFICATIONS

DN	orifice size (mm)	flow coefficient Kv (m³/h) (l/min)		pilot pressure (bar) min. max.		operating pressure differential (bar)			operator diameter (mm)	catalogue number	
						min.	max.				
							air inert gas (*)	water, oil, liquids (*)			steam (*) (≤184°C)
NO - Normally open, entry under the disc											
40	40	32	530	II (*)	10	0	11	11	10	63	T290A032
				III (*)	10	0	16	16	10	90	T290A033
		35	583	IV (*)	10	0	16	16	10	125	T290A489
50	50	39	650	III (*)	10	0	13	13	10	90	T290A035
		44	733	IV (*)	10	0	16	16	10	125	T290A490
NC - Normally closed, entry above the disc (version recommended for rapid-cycling steam applications)											
25	25	12	200	VI (*)	10	0	10	-	10	63	T290A038
32	32	18	300	VI (*)	10	0	10	-	10	63	T290A039
				VII (*)	10	0	10	-	10	90	T290A136
40	40	32	530	VI (*)	10	0	10	-	10	63	T290A040
				VII (*)	10	0	10	-	10	90	T290A041
50	50	39	650	VI (*)	10	0	9	-	9	63	T290A042
				VII (*)	10	0	10	-	10	90	T290A043

(*) Minimum pilot pressure varies with differential pressure, see page: 7 (www.asco.com)

(1) Calculation of the minimum pilot pressure at a ΔP of max. 10 bar with allowable backpressure (backpressure not recommended with liquids as waterhammer may occur) - 63, 90 and 125 mm operators, 4 bar minimum pilot pressure version: add 1,5 bar to the minimum pilot pressure of chart VI, VII or VIII [see page: 7 (www.asco.com)]

OPTIONS AND ACCESSORIES [see pages: 37 (www.asco.com) / 43 (www.asco.com)]

- Signaling box or compact signaling unit
- Stroke limiter for opening
- Manual safety device
- Adapter plate for NAMUR pad mounting pilot
- Oxygen service, pressure limited to 15 bar, temperature limited to + 60°C
- Vacuum applications up to 1,33 10⁻³ mbar
- ATEX 2014/34/EU versions for potentially explosive atmospheres (www.asco.com)

INSTALLATION

- The valves can be mounted in any position without affecting operation
- Compatible with ASTM 1, 2 and 3 oils
- Check temperature range of valve body and solenoid pilot valves for suitability. For probability of failure, contact us
- Installation/maintenance instructions are included with each valve

SPARE PARTS KITS

DN	spare parts kit no.
	Ø 63-90-125 mm
25	C140017 ⁽²⁾
32	C140018 ⁽²⁾
40	C140019 ⁽²⁾
50	C140020 ⁽²⁾

(2) Standard suffix VM also applies to kits. [see page: 37 (www.asco.com)].

DIMENSIONS (mm), WEIGHT

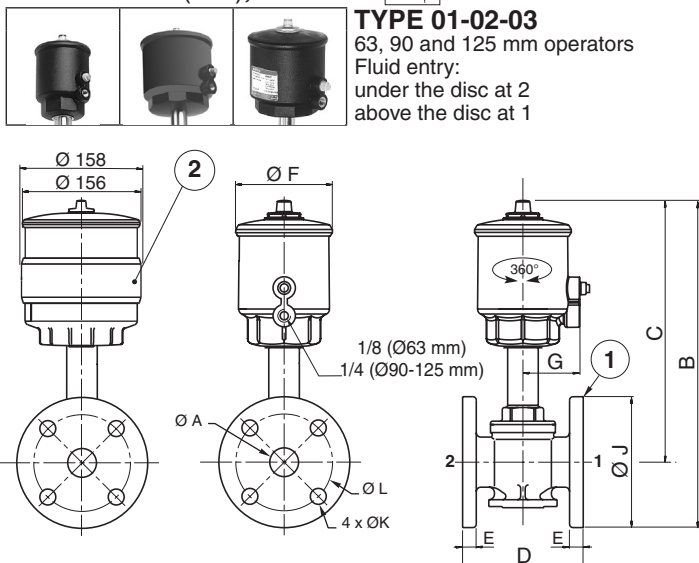

(1) Flange type 21 with flat faces, type A (ISO 7005)

(2) Operator dia. 125 mm, NO function

ORDERING EXAMPLES:

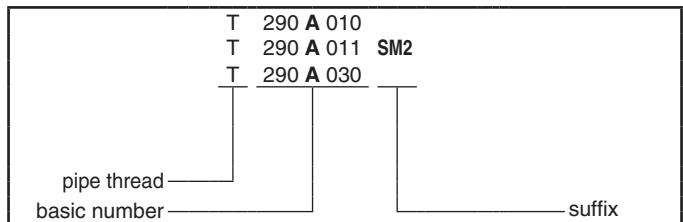

ORDERING EXAMPLES KITS:

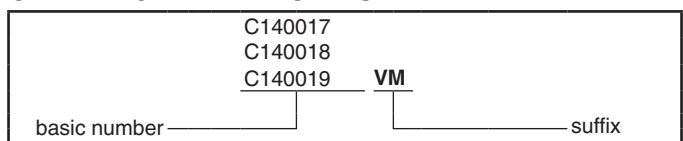

type	operator diameter	ØA	B	C	D	E	ØF	G	ØJ	ØK	ØL	weight ⁽³⁾
01	63	25	288	230	110	12	85	50,5	115	14	85	3,9
		32	313	243	130	14	85	50,5	140	18	100	5,9
		40	329	254	140	14	85	50,5	150	18	110	7,1
		50	354	271	160	16	85	50,5	165	18	125	10,5
02	90	25	303	246	110	12	118	67	115	14	85	4,5
		32	325	255	130	14	118	67	140	18	100	6,5
		40	341	266	140	14	118	67	150	18	110	7,7
03	125	50	365	283	160	16	118	67	165	18	125	11,1
		32	378	308	130	14	156	86	140	18	100	9
		40	394	319	140	14	156	86	150	18	110	10,2
		50	418	336	160	16	156	86	165	18	125	13,6

(3) Weight of valve without pilot. Add 0,2 for dia. 125 mm operator NO.

Solenoid pilot valves, see pages: 49 (www.asco.com) [63 mm operator]

51 (www.asco.com) [90 and 125 mm operators]

36 - Pressure Operated Valves (2/2)