

FEATURES

- Long service life
- Variable flow proportional to the control signal
- Ready-to-use valve
- High flow due to angled seat design
- Anti-waterhammer design (fluid entry under the disc)
- Actuator rotatable through 360°
- In option closing of the valve in case of power failure
- Fluid isolation between motorised actuator and valve body
- LED indicators for valve status display
- Valve tight at closing position (FCI 70-2 class V)
- Vacuum operation up to 10⁻² mbar
- The valves satisfy Pressure Equipment Directive 2014/64/EU, article 4.3
- The proportional motorised valves comply with the essential requirements of EMC Directive 2014/30/EU (EN-IEC 61000-6-2 et EN-IEC 61000-6-4)
- The valves satisfy all relevant EU Directives and with the provisions of the Directive RoHS 2

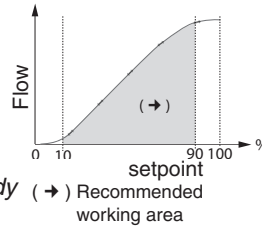

CONSTRUCTION

Differential pressure	See «SPECIFICATIONS» [1 bar =100 kPa]
Maximum allowable pressure	10 bar
Ambient temperature range	-10°C to +50°C
	-10°C to +40°C (for steam at 145°C)
Maximum viscosity	600 cSt (mm ² /s)
Actuating time	< 1,3 s (full opening) < 1,3 s (full closing)

fluids (*)	temperature range (TS)	seal materials (*)
air and gas groups 1 & 2	-10°C to +90°C	NBR (nitrile)
water, oil, liquids groups 1 & 2		
steam	up to +145°C	FPM (fluoroelastomer)

CONSTRUCTION

MATERIALS IN CONTACT WITH FLUID		
(*) Ensure that the compatibility of the fluids in contact with the materials is verified		
	NBR / PBT «K»	FPM / 316L «X»
Valve body	AISI 316L	AISI 316L
Stuffing box housing	PBT, GF reinforced	AISI 316L
Stem valve	AISI 316L	AISI 316L
Stuffing box packing	NBR	FPM
Wiper seal	NBR	FPM
Disc seal	NBR	FPM

OTHER MATERIALS

Top cover operator	Translucent polyamide (PA)
--------------------	----------------------------

ELECTRICAL CHARACTERISTICS

Connector	Spade plug (cable Ø 6-10 mm)
Connector specification	ISO 4400 / EN 175301-803, form A
Motor consumption	12 W in operation, < 2 W holding phase/set point position Max. peak current: 0,7 A
Visualisation valve (switching)	LED
Electrical enclosure protection	IP65 (EN 60529)
Standard voltages	DC (=) : 24V ±10 %, max. ripple 5%
Setpoint	0-10 V (input resistance = 10 kΩ) 4-20 mA (input resistance = 500 Ω)
Flow regulation characteristics	Linearity ±5%; hysteresis < 5%; accuracy <3%; sensitivity < 3%; repeatability <3%

(*) Ensure that the compatibility of the fluids in contact with the materials is verified.

(1) Contact us.

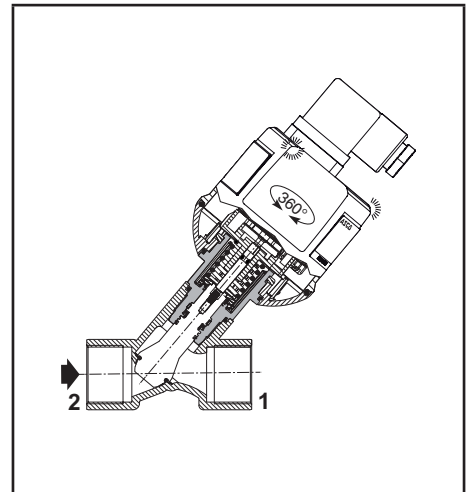

OPERATING CONDITIONS RECOMMENDATION FOR MAXIMUM DUTY CYCLE

NBR / PBT «K» version

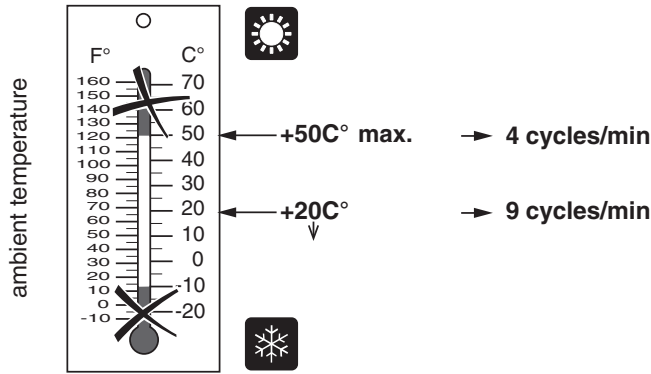

FPM / 316L «X» version

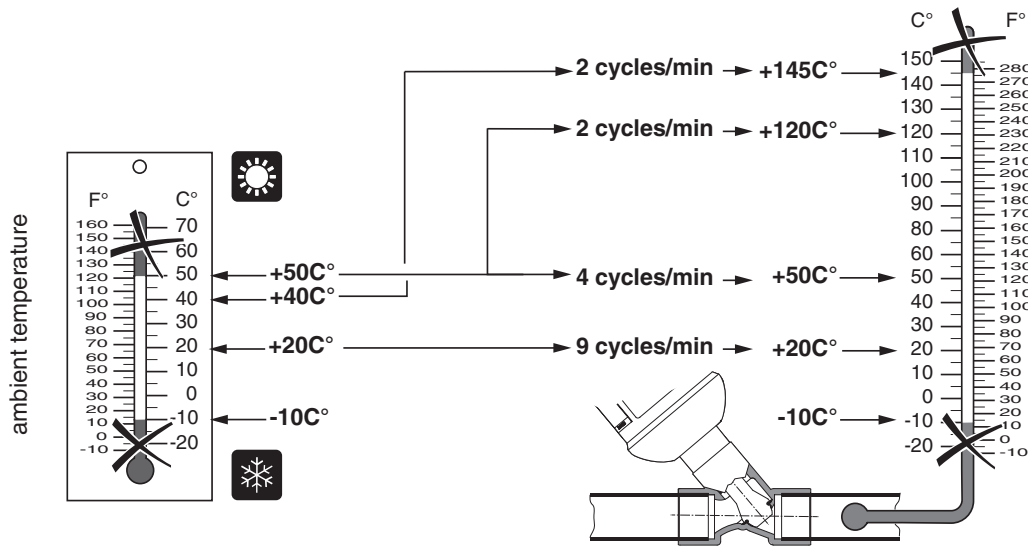

OPTIONS

Fail closed (closing of the valve in case of power failure)

SPECIFICATIONS

piping (ISO 6708)		flow coefficient Kvs (100% opening)		operating pressure differential (bar)			operator diameter (mm)	thread type	dimensions / type (2)	15-DIGIT PRODUCT CODE	
pipe size	DN	(m³/h)	(l/min)	min.	max.					basic code	voltage code
					air, water, oil (*)	steam					
Motorised valve, entry under the disc (4-20 mA) - NBR / PBT «K» version											
3/8	10	2,7	45	0	6	-	67	G*	1	E290CP2V0K4MA	V1
1/2	15	3,8	63	0	5	-	67	G*	1	E290CP3V0K4MA	
3/4	20	6	100	0	4	-	67	G*	1	E290CP4V0K4MA	
Motorised valve, entry under the disc (0-10 V) - NBR / PBT «K» version											
3/8	10	2,7	45	0	6	-	67	G*	1	E290CP2V0K00V	V1
1/2	15	3,8	63	0	5	-	67	G*	1	E290CP3V0K00V	
3/4	20	6	100	0	4	-	67	G*	1	E290CP4V0K00V	
Motorised valve, entry under the disc (4-20 mA) - FPM / 316L «X» version											
3/8	10	2,7	45	0	6	4	67	G*	1	E290CP2V0X4MA	V1
1/2	15	3,8	63	0	5	4	67	G*	1	E290CP3V0X4MA	
3/4	20	6	100	0	4	4	67	G*	1	E290CP4V0X4MA	
Motorised valve, entry under the disc (0-10 V) - FPM / 316L «X» version											
3/8	10	2,7	45	0	6	4	67	G*	1	E290CP2V0X00V	V1
1/2	15	3,8	63	0	5	4	67	G*	1	E290CP3V0X00V	
3/4	20	6	100	0	4	4	67	G*	1	E290CP4V0X00V	

(2) For dimensions, see drawing(s) for each construction type on the following page(s).

(*) Ensure that the compatibility of the fluids in contact with the materials is verified.

15-DIGIT PRODUCT CODE

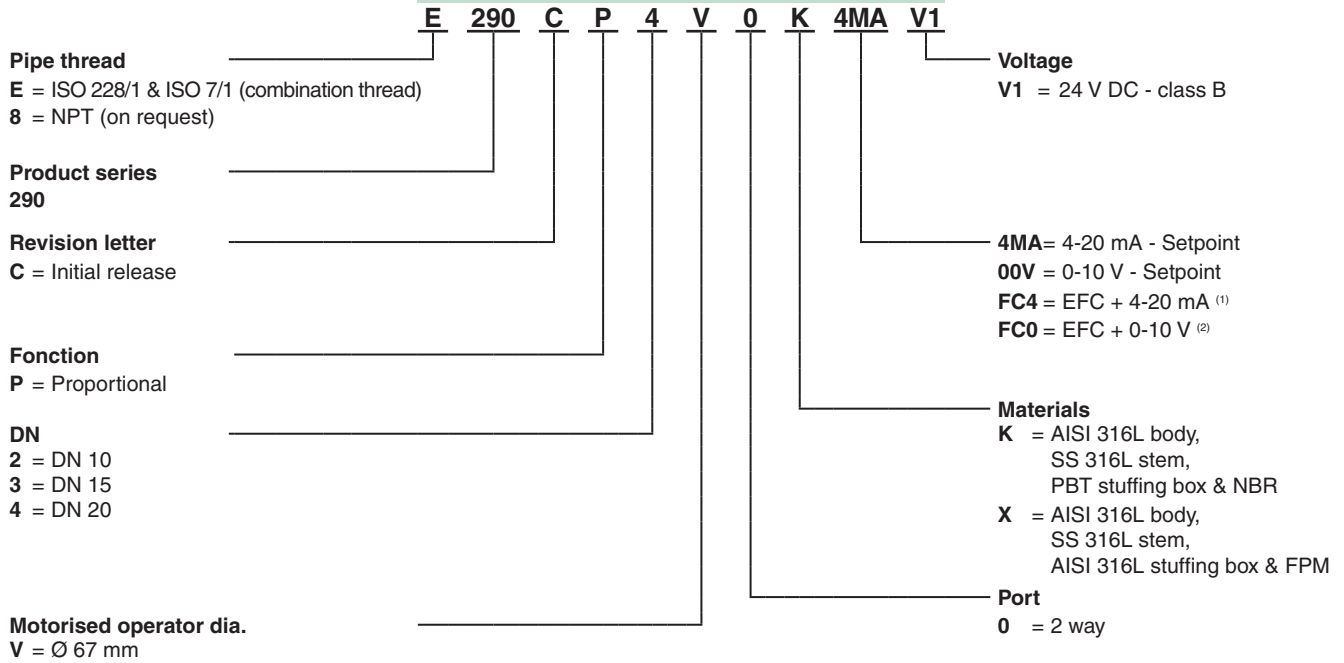





⁽¹⁾ Closing of the valve in case of power failure. Set point 4-20 mA.
⁽²⁾ Closing of the valve in case of power failure. Set point 0-10 V.

INSTALLATION

- The valves can be mounted in any position without affecting operation
- Pipe connections (G*) have standard combination thread according to ISO 228/1 and ISO 7/1
- Other pipe connections are available on request
- Installation/maintenance instructions are included with each valve
- LED indicators for operating status display

status	valve OPEN	green
	valve CLOSED	orange
	valve moves to open	green flashing
	valve moves to close	green flashing

WIRING DC

24 V ±10 % / DC	
	1 24 V / DC
	2 0 V
	3 setpoint (0-10 V or 4-20 mA)
	4 feedback signal (24 V switch)

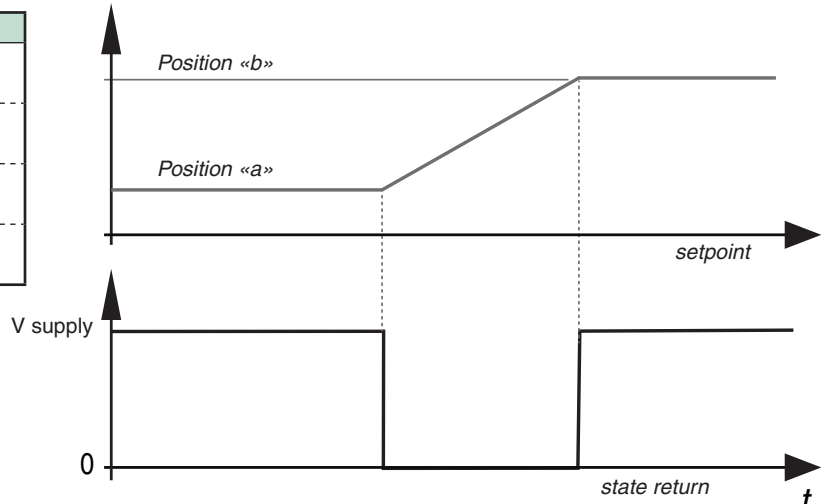

DIMENSIONS (mm), WEIGHT (kg)



[Configurator - CAD Files](#)



TYPE 01

DC version
67 mm motorised operator
Fluid entry: under the disc at 2
ISO 4400 connector

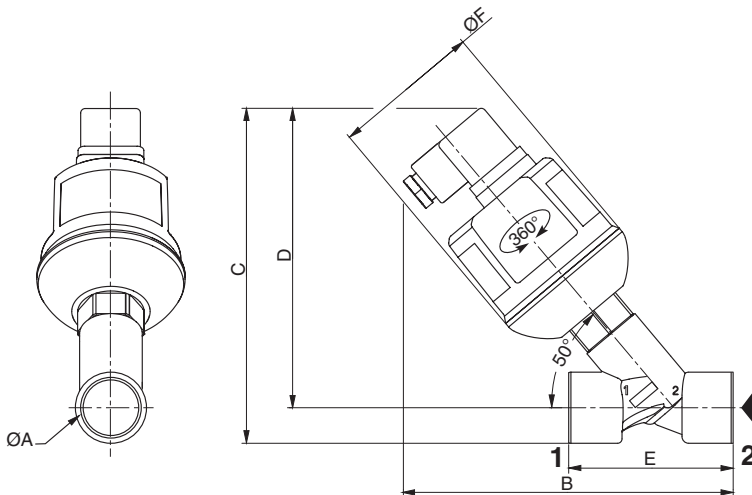

type	Ø A	B	C	D	E	Ø F	weight ⁽¹⁾	
							NBR / PBT «K»	FPM / 316L «X»
DC version								
01	3/8	135	141	129	55	67	0,40	0,45
	1/2	142	145	131	65	67	0,45	0,55
	3/4	150	152	136	75	67	0,55	0,65

⁽¹⁾ Incl. connector.