

Reliability and long service life

Anti-waterhammer design

Backpressure resistant

Angle-seat valves

series 290-390

- Excellent flow rate
- PN16
- Max. fluid temperature +180°C
- Max. ambient temperature +60°C

Easy assembly

Operator rotatable through 360° to position the piloting port

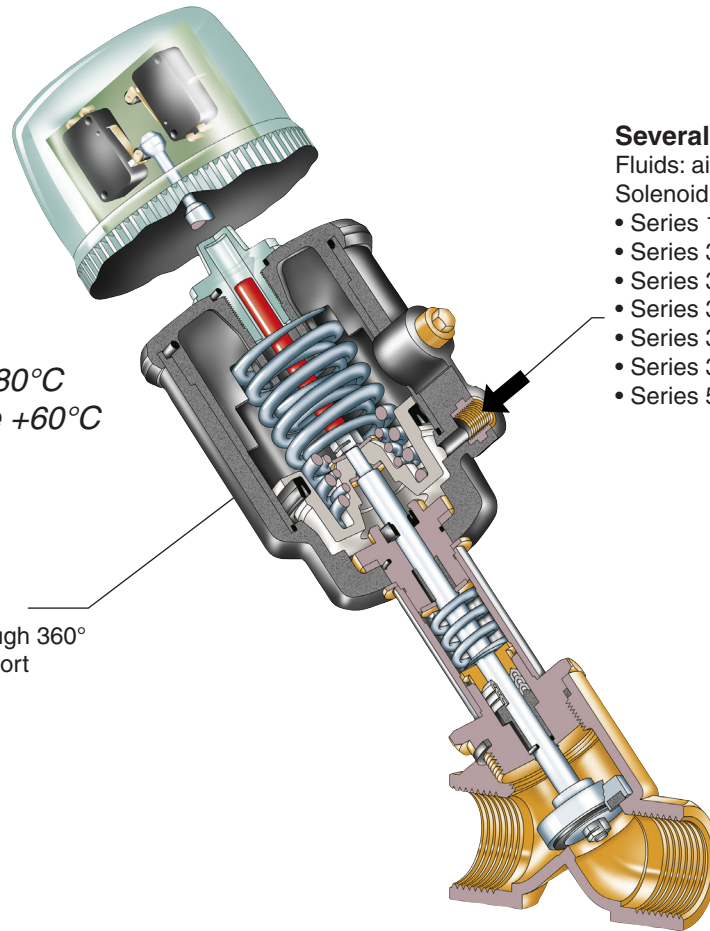

Several piloting choices:

Fluids: air or water from 1,5 to 10 bar

Solenoid pilot valves:

- Series 189 Banjo Ø 1,2 mm
- Series 356 Ø 1,6 mm G1/8-1/4
- Series 314 Ø 3,2 mm
- Series 325 Ø 1,2 mm
- Series 314 Ø 1,2 - 2,4 et 3,2 mm
- Series 320 Ø 3,2 mm
- Series 551 NAMUR with interface

Globe valves

series 298-398

- Thermal shock resistant
- PN40
- Max. fluid temperature +250°C
- Max. ambient temperature +180°C
- 3/2 Universal
- Simple and easy maintenance, fully disassemblable valve

Bi-directional fluid flow

Pressure can be applied to any orifice as required by the process

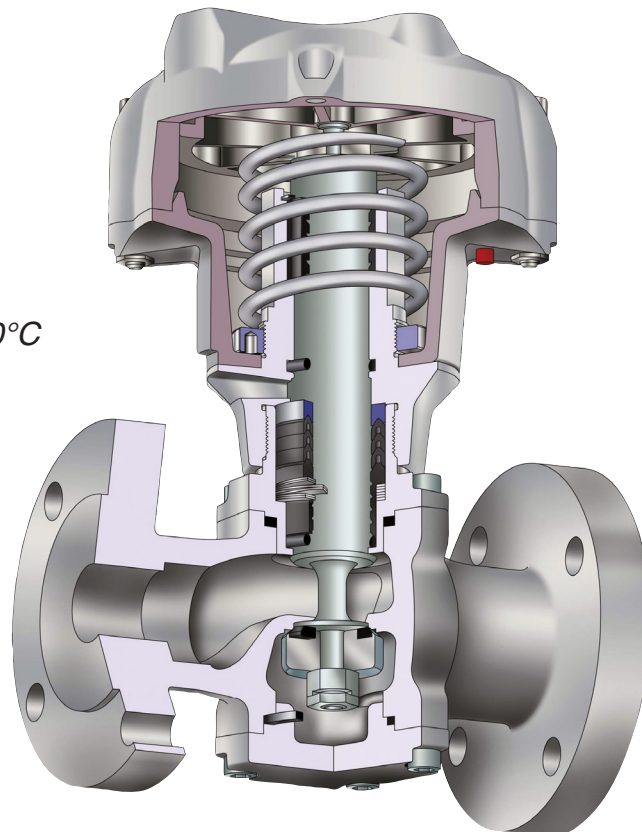

A wide range of valves for all fluid applications

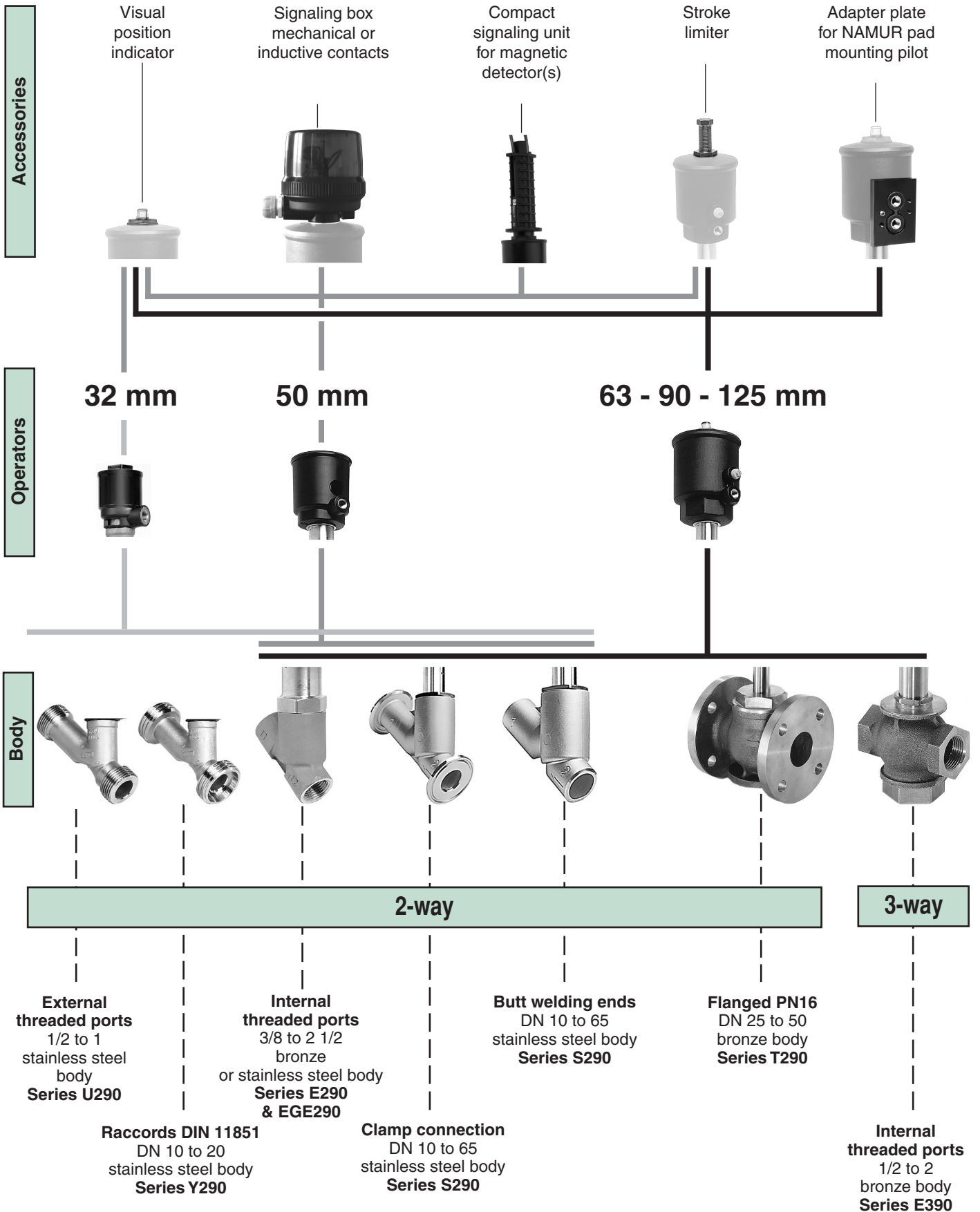

For exact material selection and combinations, refer to the appropriate catalogue pages.



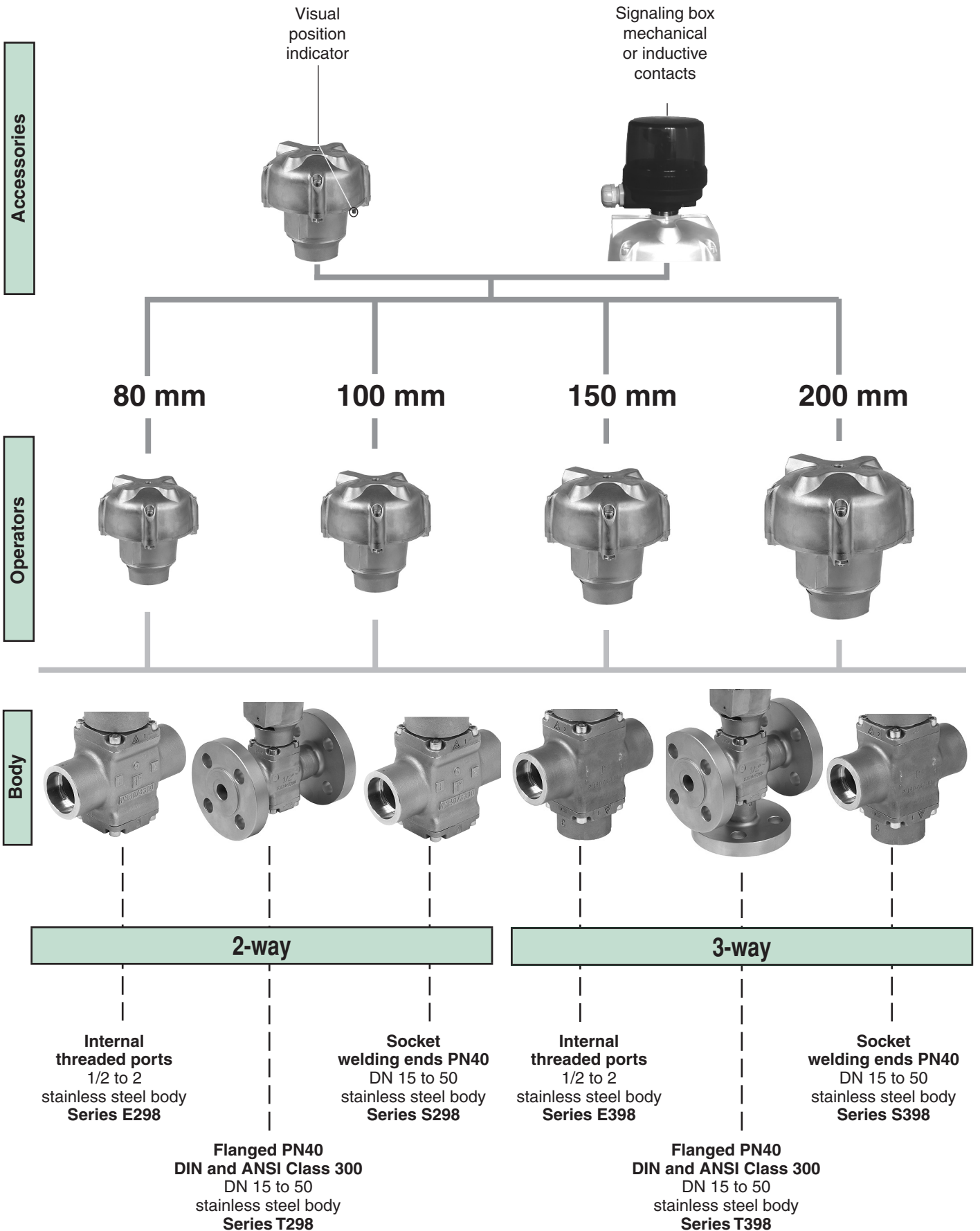

A wide range of valves for all fluid applications







00047GB-2017/R01
Availability, design and specifications are subject to change without notice. All rights reserved.

For exact material selection and combinations, refer to the appropriate catalogue pages.

GENERAL SPECIFICATIONS

2/2 VALVES (Functions NC - NO)						
series		E290	E290	U290	Y290	S290
connection		internal thread	internal thread	ext. thread	DIN 11851	Clamp / butt welding ends
body		1/2 to 2 1/2 bronze	3/8 to 2 1/2 stainless steel ⁽¹⁾	1/2 to 1 st. steel ⁽¹⁾	DN 10 to 20 all AISI 316L	DN 10 to 65 stainless steel ⁽¹⁾
FLUIDS:	neutral aggressive steam (10 bar max.)	• • •	• • •	• • •	• • •	• • •
FLUID TEMPERATURE		-10°C to +184°C				
DIFFERENTIAL PRESSURE		0 - 16 bar				
MAXIMUM ALLOWABLE PRESSURE		16 bar				
AMBIENT TEMPERATURE		-10°C to +60°C				
PILOT FLUID		filtered air or water				
PILOT FLUID TEMPERATURE		-10°C to +60°C				
OPERATOR		32, 50, 63, 90, 125 mm				
PILOT PRESSURE		2,5 / 4 to 10 bar ⁽²⁾				
	NC (fluid entry under disc)	see page: 7 ⁽²⁾				
	NO (fluid entry under disc)	see page: 7 ⁽²⁾				
	NC (fluid entry above disc)	see page: 7 ⁽²⁾				
CATALOGUE PAGE		15 (www.asco.com)	15 (www.asco.com) 19 (www.asco.com)	23 (www.asco.com) 25 (www.asco.com)	27 (www.asco.com) 31 (www.asco.com)	27 (www.asco.com) 31 (www.asco.com)





2/2 - 3/2 VALVES (Functions NC - NO)						
series		T290	E390	EGE290		
connection		2/2, flanged	3/2, internal thread	gas service	proportional	
body		DN 25 to 50 bronze	1/2 to 2 bronze	1/2 to 2 bronze / stainless steel	3/8 to 2 acier inox	
				1/2 to 1 1/2 acier inox		
FLUIDS:	neutral steam (10 bar max.) combustible gas (EN 161)	• • •	• • •	• • •	• • •	
FLUID TEMPERATURE		-10°C to +184°C	-10°C to +184°C	-10°C to +60°C	-10°C to +60°C	0°C to +50°C
DIFFERENTIAL PRESSURE		0 - 16 bar	0 - 16 bar	0 - 10 bar	0 - 1 bar	1 bar
MAXIMUM ALLOWABLE PRESSURE		16 bar	16 bar	-	-	16 bar
AMBIENT TEMPERATURE		-10°C to +60°C	-10°C to +60°C	-	-	0°C to +50°C
PILOT FLUID		filtered air or water	filtered air or water	air	air/inert gas	air/inert gas
PILOT FLUID TEMPERATURE		-10°C to +60°C	-10°C to +60°C	-10°C to +60°C	-	0°C to +50°C
OPERATOR		63, 90, 125 mm	63, 90, 125 mm	63 mm	32, 63 mm	63 mm
PILOT PRESSURE		2,5 / 4 to 10 bar ⁽²⁾	3 / 5 to 10 bar ⁽²⁾	-	5,5/3,5..9 bar	5 to 8 bar
	NC (fluid entry under disc)	see page: 7 ⁽²⁾	see page: 7 ⁽²⁾	-	-	-
	NO (fluid entry under disc)	see page: 7 ⁽²⁾	-	5 à 9 bar	-	-
	NC (fluid entry above disc)	see page: 7 ⁽²⁾	-	-	-	-
		Pressure Operated Valves (2/2) ▼	Pressure Operated Valves (3/2) ▼	Combustible Gas & Oil (3/2) ▼		
CATALOGUE PAGE		35 (www.asco.com)	www.asco.com	entry above the disc www.asco.com	entry under the disc www.asco.com	www.asco.com





⁽¹⁾ All stainless steel AISI 316L versions on request.

⁽²⁾ Pilot pressure lower than indicated minimum, contact us.

4 - Pressure Operated Valves (2/2)

GENERAL SPECIFICATIONS

2/2 VALVES (Functions NC - NO)					
series		E298	T298	S298	proportional
connection		internal thread	flanged	socket welding ends	E298/T298/W298
body		PN40	PN40, DIN and ANSI Class 300	PN40	all
		1/2 to 2	DN 15 to 50	DN 15 to 50	PN40
		stainless steel	stainless steel	stainless steel	stainless steel
FLUIDS:	neutral	•	•	•	•
	aggressive	•	•	•	•
	superheated water	•	•	•	•
	steam (10 bar max.)	•	•	•	•
FLUID TEMPERATURE			-10°C to +250°C		-10°C to +233°C
DIFFERENTIAL PRESSURE			0 - 40 bar		0 - 40 bar
MAXIMUM ALLOWABLE PRESSURE			40 bar		40 bar
ALLOWABLE BACKPRESSURE			up to 40 bar		-
AMBIENT TEMPERATURE			-25°C to +180°C (autoclavable valve)		0°C to +50°C
PILOT FLUID			filtered air		filtered air
PILOT FLUID TEMPERATURE			-10°C to +60°C		0°C to 20°C
OPERATOR			80, 100, 150, 200 mm		80, 100, 150, 200 mm
PILOT PRESSURE			max. 10 bar ⁽¹⁾		4 to 8 bar
					Proportional Valves
					▼
CATALOGUE PAGE		53 (www.asco.com)	57 (www.asco.com)	61 (www.asco.com)	www.asco.com

3/2 VALVES (U, mixer / distributor functions)					
series		E398	T398	S398	proportional
connection		internal thread	flanged	socket welding ends	E398/T398/W398
body		PN40	PN40, DIN and ANSI Class 300	PN40	all
		1/2 to 2	DN 15 to 50	DN 15 to 50	PN40
		stainless steel	stainless steel	stainless steel	stainless steel
FLUIDS:	neutral	•	•	•	•
	aggressive	•	•	•	•
	superheated water	•	•	•	•
	steam (10 bar max.)	•	•	•	•
FLUID TEMPERATURE			-10°C to +250°C		-10°C to +233°C
DIFFERENTIAL PRESSURE			0 - 40 bar		0 - 40 bar
MAXIMUM ALLOWABLE PRESSURE			40 bar		40 bar
AMBIENT TEMPERATURE			-25°C to +180°C		0°C to +50°C
PILOT FLUID			filtered air		filtered air
PILOT FLUID TEMPERATURE			-10°C to +60°C		0°C to 20°C
OPERATOR			80, 100, 150, 200 mm		80, 100, 150, 200 mm
PILOT PRESSURE			max. 10 bar ⁽¹⁾		4 to 8 bar
			Pressure Operated Valves		Proportional Valves
			(3/2)		
		▼	▼	▼	▼
CATALOGUE PAGE		www.asco.com	www.asco.com	www.asco.com	www.asco.com

⁽¹⁾ min. pilot pressure: See pilot pressure graphs on the respective catalogue page.

Selection and operation of a valve depend on two parameters:

- The maximum differential pressure (ΔP) across the valve in closed position
- The minimum pilot pressure necessary to control the valve

Series 290 - 390 valves can be equipped with diameter 32, 50, 63, 90 or 125 mm operators.

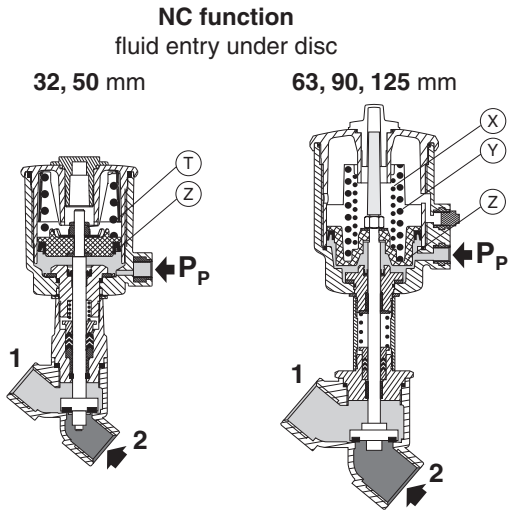

The valve is kept in the closed position by spring (T) (X) and/or (Y). It is opened by pilot pressure (Pp) under the piston (Z).

The operators are standard available as follows:

operators	return spring	pilot pressure (bar)		range of applications
		min.	max.	
32 - 50	T	4	10	high ΔP typical applications
63 - 90 - 125	X + Y	4	10	

To meet the requirements of different applications, 63-90-125 mm operators are available in two other versions:

63 - 90 - 125	Y	2,5	10	average ΔP low pilot pressure
	X	1,5	10	low ΔP very low pilot pressure

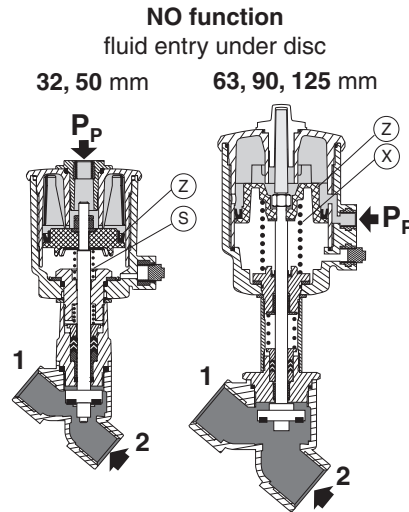

The valves are kept in the open position by return spring (S) or (X).

The valve is closed by pilot pressure (Pp) on piston (Z).

In the closed position, the pilot pressure must overcome the force of the return spring and that created by the ΔP under the disc.

The minimum pilot pressure varies as a function of the ΔP to which the valve is subjected.

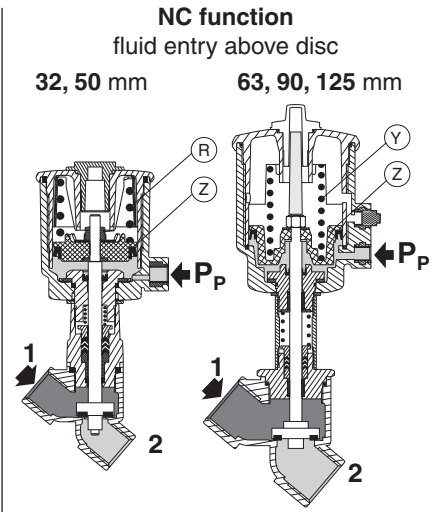

This function is recommended for steam systems (184°C max.) with high cycling rates.

Not to be used with liquids as waterhammer may occur.

Valves are maintained in the closed position by spring (R) or (Y).

The valve is opened by pilot pressure (Pp) under piston (Z). The pilot pressure must overcome the force of the return spring and that generated by the ΔP on the disc.

The minimum pilot pressure varies as a function of the ΔP to which the valve is subjected.

Series 298 - 398 valves can be equipped with diameter 80, 100, 150 or 200 mm operators.

The minimum pilot pressure varies as a function of the ΔP to which the valve is subjected. Low pilot pressure operation is standard on all 298 - 398 valves.

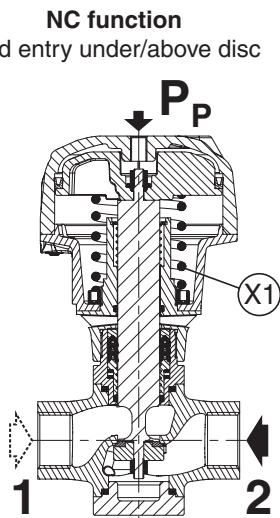

The valve is kept in the closed position by spring (X1). It is opened by pilot pressure (Pp).

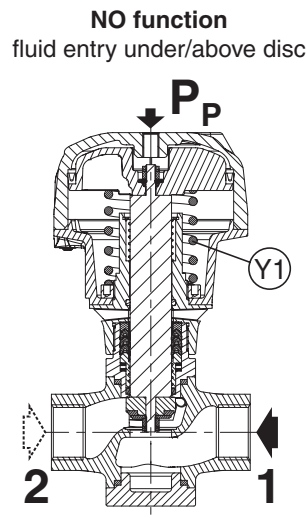

The valves are kept in the open position by return spring (Y1). It is closed by pilot pressure (Pp).

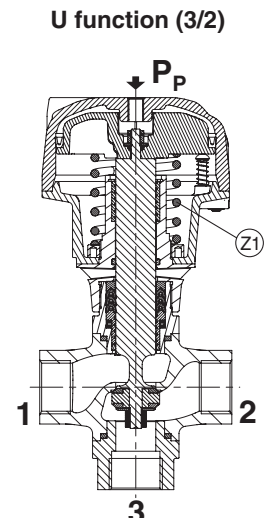

The valves are held in position by return spring (Z1). Pilot pressure (Pp).

SELECTION OF THE MINIMUM PILOT PRESSURE

series 290 / 390

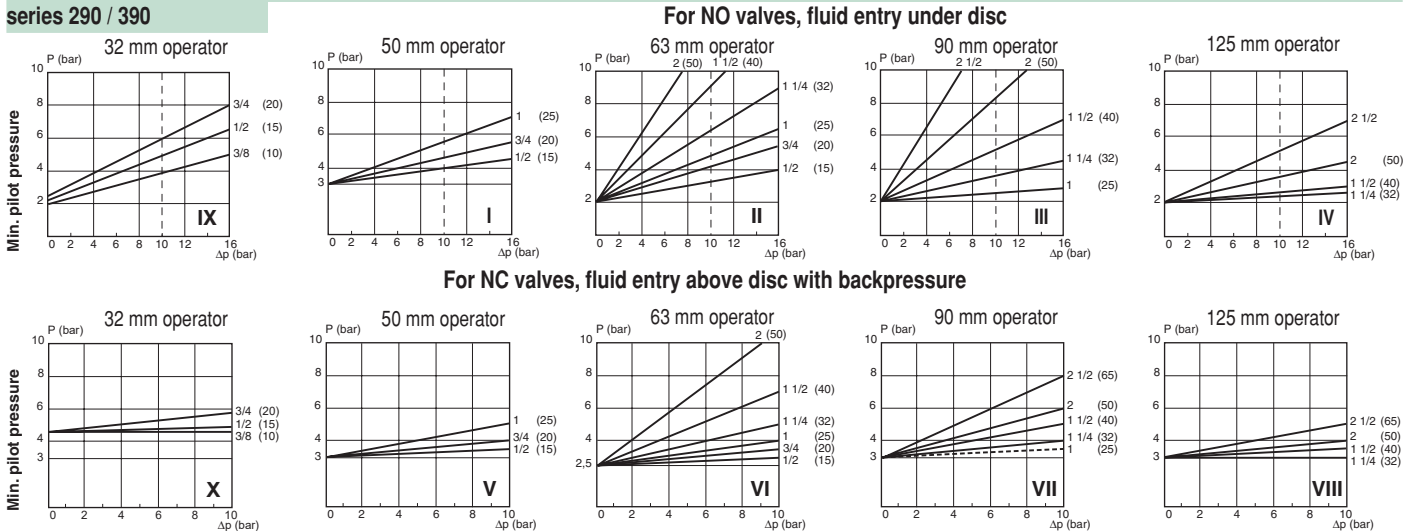

series 298 / 398

See graphs on pages: **2/2: 53** (www.asco.com), **57** (www.asco.com), **61** (www.asco.com)
3/2: 3 (www.asco.com), **7** (www.asco.com), **11** (www.asco.com)

SELECTION OF PILOT VALVE TYPE FOR REQUIRED RESPONSE TIMES

Response times of valves depend on the Kv of the pilot valve or positioner used and the size of the valve, as shown in the following tables.

series 290 / 390	Response time (in seconds) for NC valve series 290/390 (6 bar pilot air)																								
	32 mm operator			50 mm operator			63 mm operator			90 mm operator			125 mm operator												
	Ø (DN)	pilots		pilots		pilots		pilots		pilots		pilots		pilots											
	O ⁽¹⁾	C ⁽¹⁾	O ⁽¹⁾	C ⁽¹⁾	O ⁽¹⁾	C ⁽¹⁾	O ⁽¹⁾	C ⁽¹⁾	O ⁽¹⁾	C ⁽¹⁾	O ⁽¹⁾	C ⁽¹⁾	O ⁽¹⁾	C ⁽¹⁾											
	A	-	A	-	A	C1	F1	A	C1	F1	A	C1	F1	D	E	F1	D	E	F1	D	E	F1	D	E	F1
3/8 (10)	0,05	-	0,01	-	-	-	-	-	-	-	-	-	-	-	-	-	-	-	-	-	-	-	-	-	-
1/2 (15)	0,05	-	0,01	-	0,14	0,09	0,9	0,9	0,14	0,16	-	-	-	-	-	-	-	-	-	-	-	-	-	-	-
3/4 (20)	0,05	-	0,01	-	0,17	0,09	0,9	0,9	0,23	0,23	1	1	1	-	-	-	-	-	-	-	-	-	-	-	-
1 (25)	-	-	-	-	0,17	0,10	0,9	0,9	0,23	0,22	2	2	2	0,2	0,2	0,2	0,2	0,2	0,2	0,2	0,2	0,2	0,2	0,2	0,2
1 1/4 (32)	-	-	-	-	-	-	-	-	-	0,37	0,37	2	2	2	0,2	0,2	0,2	0,2	0,2	0,2	0,2	0,2	0,2	0,2	0,2
1 1/2 (40)	-	-	-	-	-	-	-	-	-	0,32	0,32	2	2	2	0,2	0,2	0,2	0,2	0,2	0,2	0,2	0,2	0,2	0,2	0,2
2 (50)	-	-	-	-	-	-	-	-	-	0,37	0,37	2	2	2	0,2	0,2	0,2	0,2	0,2	0,2	0,2	0,2	0,2	0,2	0,2
2 1/2 (65)	-	-	-	-	-	-	-	-	-	0,32	0,32	2	2	2	0,2	0,2	0,2	0,2	0,2	0,2	0,2	0,2	0,2	0,2	0,2

The times indicated for opening (O) and closing (C) of the valve corresponds to:

- 1/8, 32-50-63 mm operators, 3/2 pilots: [see page 49 (www.asco.com)]
- A: series 189 banjo - orifice size 1,2 mm, max. pilot pressure 10 bar
- C1: series 356 1/8 - Ø1,6 mm, max. pilot pressure 10 bar
- F1, Positioner²: max. pilot pressure 8 bar ⁽²⁾ (www.asco.com)

- 1/4, 90-125 mm operators, 3/2 pilots: [see page 51 (www.asco.com)]
- D: series 314 1/4 - Ø3,2 mm, max. pilot pressure 10 bar
- E: series 356 1/4 - Ø1,6 mm, max. pilot pressure 10 bar

series 298 / 398	Response time (in seconds) for NC valve series 298/398 (6 bar pilot air)																	
	80 mm operator				100 mm operator				150 mm operator				200 mm operator					
	O		C		O		C		O		C		O		C			
	pilots		pilots		pilots		pilots		pilots		pilots		pilots		pilots			
	C1	F1	C1	F1	C1	F1	C1	F1	D	E	F1	D	E	F1	D	E	F1	
Ø (DN)	2/2 NC ⁽¹⁾	3/2 U	2/2-3/2	2/2 NC ⁽¹⁾	3/2 U	2/2-3/2	2/2 NC ⁽¹⁾	3/2 U	2/2-3/2	2/2 NC ⁽¹⁾	3/2 U	2/2-3/2	2/2 NC ⁽¹⁾	3/2 U	2/2-3/2	2/2 NC ⁽¹⁾	3/2 U	2/2-3/2
2/2 VALVES NC/NO and 3/2 U																		
1/2 (15)	0,05	0,07	0,35	0,74	0,69	0,65	-	-	-	-	-	-	-	-	-	-	-	-
3/4 (20)	-	-	-	-	-	-	0,08	0,13	0,48	0,48	0,77	1,59	1,02	0,08	0,09	0,76	0,77	0,90
1 (25)	-	-	-	-	-	-	0,08	0,13	0,48	0,48	0,77	1,59	1,02	0,08	0,09	0,76	0,77	0,90
1 1/4 (32)	-	-	-	-	-	-	0,08	0,13	0,48	0,48	0,77	1,59	1,02	0,08	0,09	0,76	0,77	0,90
1 1/2 (40)	-	-	-	-	-	-	0,08	0,13	0,48	0,48	0,77	1,59	1,02	0,08	0,09	0,76	0,77	0,90
2 (50)	-	-	-	-	-	-	0,08	0,13	0,48	0,48	0,77	1,59	1,02	0,08	0,09	0,76	0,77	0,90

The times indicated for opening (O) and closing (C) of the valve corresponds to:

- 1/8, 80-100 mm operators, 3/2 pilots: [see page 71 (www.asco.com)] - 1/4, 150-200 mm, operators 3/2 pilots: [see page 73 (www.asco.com)]
- C1: series 356 1/8 - Ø1,6 mm, max. pilot pressure 10 bar
- (¹) Values for NC valves. For NO valves, interchange O and C values.
- F1, Positioner²: max. pilot pressure 8 bar ⁽²⁾ (www.asco.com)
- D: series 314 1/4 - Ø3,2 mm, max. pilot pressure 10 bar
- E: series 356 1/4 - Ø1,6 mm, max. pilot pressure 10 bar

⁽²⁾ See section: "Proportional Valves"

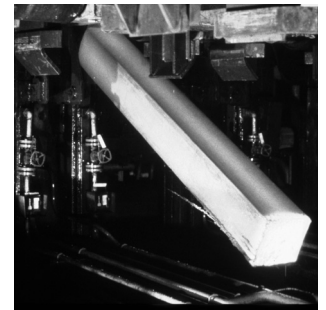
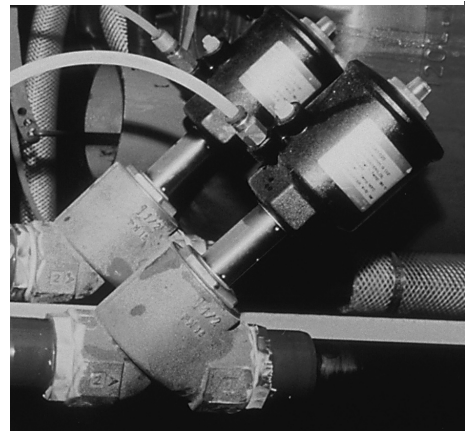
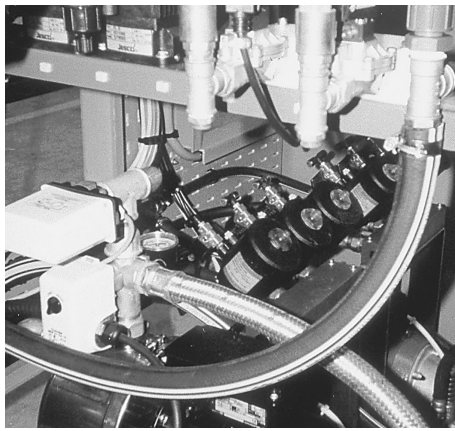
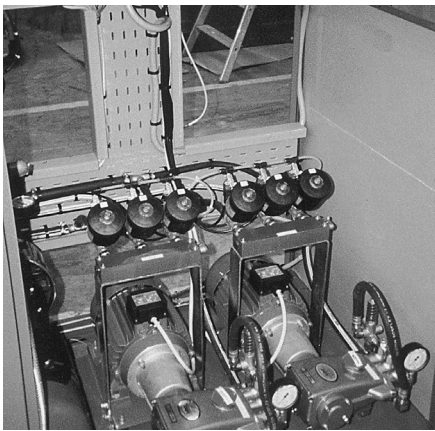
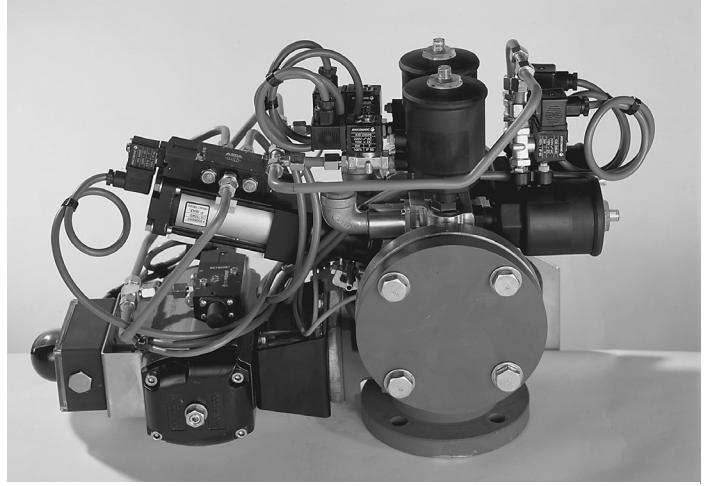
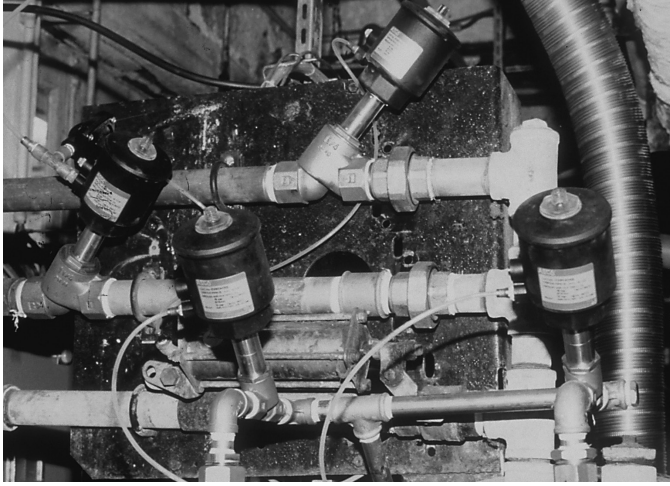

1	2
3	4 5
6	7 8

Series 290 - 390

- 1 Industrial laundry (steam circuit)
- 2 Special machinery
- 3 Special machinery with steam circuit
- 4 Food processing
- 5 Chemical product processing

Series 298 - 398

- 6 Autoclaves and industrial boilers
- 7 Tyre press or rubber parts applications (vulcanisation)
- 8 Iron and steel industry