

FEATURES

- Valves for combustible gas, bronze or stainless steel body
- Valves satisfy the Pressure Equipment Directive 2014/68/EU, EN 161 and satisfy the Regulation (EU) 2016/426 on gas appliances
EU type examination certificate no.: CERTIGAZ 1312CN5765
These valves are certified for operation up to 10 bar, instead of 4 bar as required under Standard EN 161
- All valves are for class A - Groupe 2 service and cover gas family 1 - 2 and 3
- All valves are suitable to withstand 150 mbar back pressure
- High flow due to angled seat design - fluid entry above the disc
- High performance maintenance-free stuffing box

GENERAL

fluids	temperature range (TS)	disc seal
gas family 1 - 2 - 3	-10°C to +60°C	PTFE

Differential pressure 0 to 10 bar [1 bar =100 kPa]
Time for closing / for opening 1 s max. with pilot solenoid valve directly connected to valve operator

Note: Opening and closing times depend on using pilot valves meeting the requirements in the table below

Pilot fluid Air
Max. pilot pressure 9 bar
Min. pilot pressure 5 bar - see graph following page
Pilot fluid temperatur -10°C to +60°C

CONSTRUCTION

Valve body Bronze or stainless steel
Stuffing b x packing PTFE chevrons
Disc seal PTFE
Operator Glass fibre filled PA
Pilot port insert Brass

PILOT SOLENOID VALVES SELECTION

- Must meet European low voltage directive and electromagnetic compatibility requirements
- Non-locking NC 3/2 versions
- Must allow the main valve to close automatically as per standard EN 161

operator diameter (mm)	Kv (m ³ /h) min. ⁽¹⁾ through pilot valve required to		response time (ms) through pilot valve required to		pilot valve recommended (without manual operator)	
	close the valve	open the valve	close the valve	open the valve	designation	catalogue number
63	0,04	0,04	10	7	356 G1/8 Ø1,2	SCG356B061V

⁽¹⁾ Including pipe up to main valve.

SPECIFICATIONS

piping (ISO 6708)		flow ⁽⁴⁾			pilot pressure ⁽⁵⁾ (bar)		operating pressure differential (bar)		operator diameter (mm)	catalogue number		
pipe size	DN	(m ³ /h)		(l/min)	min.	max.	min.	max.		bronze G*	stainless steel G* NPT	
NC - Normally closed, entry above disc												
1/2	1/2	15	19	320	5	9	0	10	63	EGE290B036	EGE290B079	EG8290B079
3/4	3/4	20	39	650	5	9	0	10	63	EGE290B037	EGE290B080	EG8290B080
1	1	25	54	900	5	9	0	10	63	EGE290B038	EGE290B081	EG8290B081
1 1/4	1 1/4	32	102	1700	5	9	0	10	63	EGE290A039	EGE290A082	EG8290A082
1 1/2	1 1/2	40	144	2400	5	9	0	10	63	EGE290A040	EGE290A083	EG8290A083
2	-	50	180	3000	5	9	0	9	63	EGE290A042	EGE290A085	-

⁽⁴⁾ For 2,5 mbar pressure drop air 1,0 s.g. at 1,013 mbar and 15°C.

⁽⁵⁾ Pilot pressure varies with differential pressure. See graph following page.

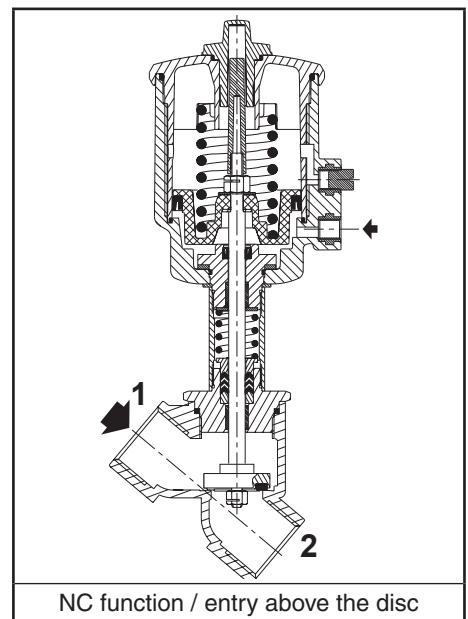

INSTALLATION

- Install strainer upstream of valve with a mesh size below 1.5 mm through which a 1 mm dia. rod cannot pass
- The valves can be mounted in any position without affecting operation
- Installation/maintenance instructions are included with each valve
- Spare parts kits are available

DIMENSIONS (mm), WEIGHT (kg)



TYPE 01

63 mm operator
Fluid entry:
above the disc at 1

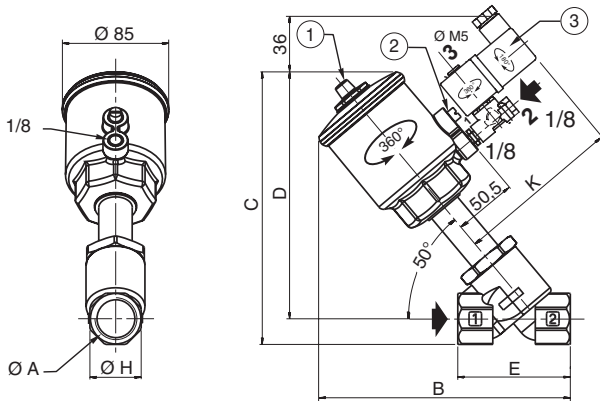

type	operator diameter	ØA	B	C	D	E	F	H ⁽¹⁾	weight	
									⁽²⁾	⁽³⁾
01	63 mm	1/2	170	182	169	65	27	125,5	1,2	1,37
		3/4	175	185	170	75	32	125,5	1,3	1,47
		1	179	192	172	90	41	125,5	1,7	1,87
		1 1/4	217	229	204	110	50	125,5	2,1	2,27
		1 1/2	224	245	215	120	60	125,5	2,9	3,07
		2	249	259	224	150	70	125,5	3,7	3,87

- ⁽¹⁾ Maximum size with pilot.
⁽²⁾ Weight of the valves without pilot.
⁽³⁾ Weight of the valves with pilot.

- ① Optical position indicator
② Filter-plug (non-removable)
③ Pilot solenoid valve despatched separately: see preceding page