



SOLENOID VALVES

direct operated
for high pressure fluids

1/8 - 1/4

15 mm compression fittings

NC

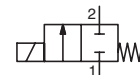

NO

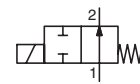

2/2
Series
262

FEATURES

- High operating pressure
- RoHS compliance
- AC/DC interchangeability of the coil possible only for NC (10,1 W/11,6 W and 17,1 W/22,6 W)
- Valves do not require a minimum operating pressure
- Large selection of seal materials providing wide chemical compatibility
- Compliance with UL and CSA standards
- The solenoid valves satisfy all relevant EU directives

GENERAL

Differential pressure
Maximum viscosity
Response time

See «SPECIFICATIONS» [1 bar = 100 kPa]
65 cSt (mm²/s)
5 - 25 ms

fluids (*)	temperature range (TS)	seal materials (*)
air, inert gas, water, oil	-25°C to +80°C	NBR (nitrile)
	0°C to +60°C	UR (cast urethane)

GENERAL

MATERIALS IN CONTACT WITH FLUID

(*) Ensure that the compatibility of the fluids in contact with the materials is verified

Body	Brass	Stainless steel, AISI 304
Shading coil	Copper	Silver
Core tube	Stainless steel, AISI 305	
Core and plugnut	Stainless steel, AISI 430F	
Springs	Stainless steel, AISI 302	
Seal	NBR	
Disc	NBR or UR	
Disc holder (NO function)	PA	

ELECTRICAL CHARACTERISTICS

Coil insulation class	F (AC) or H (DC)
Connector	Spade plug (cable Ø 6-10 mm)
Connector specification	ISO 4400 / EN 175301-803, form A
Electrical safety	IEC 335
Electrical enclosure protection	Moulded IP65 (EN 60529)
Standard voltages	DC (=) : 24V - 48V
(Other voltages and 60 Hz on request)	AC (~) : 24V - 48V - 115V - 230V/50 Hz

operator ambient temperature range (TS) (°C)	power ratings			replacement coil ⁽¹⁾	
	inrush ~ (VA)	holding ~ (VA)	hot/cold = (W)	~ 230 V/50 Hz	= 24 V DC
-25 to +55	30	16	8,1	7,7/ 10,6	238213-059 238513-006
	45	20	11,1	12,5/18,6	238213-157 238513-106
	50	25	10,1	8,5/11,6	238613-059 238913-006
	70	40	17,1	15,1/22,6	238613-159 238913-106

⁽¹⁾ All 238 basic numbers are UL & CSA approved and marked with the UR (recognised component) & CSA logos.

OPTIONS

Seals and disc (*) ⁽²⁾ (fluid temperature range)	FPM (fluoroelastomer): -15°C to +100°C (coil class F) -15°C to +120°C (coil class H) EPDM (ethylene-propylene), 0°C to +100°C CR (chloroprene), 0°C to +80°C PTFE: -15°C to +100°C (coil class F) -15°C to +120°C (coil class H)
Oxygen service, FPM disc and seals, see "15-DIGIT PRODUCT CODE"	
WRAS approval, EPDM disc and seals, see "15-DIGIT PRODUCT CODE"	
Magnetic latching versions, reverse polarity DC voltages, see "15-DIGIT PRODUCT CODE FOR MAGNETIC LATCHING VERSION ONLY"	
15 mm compression-fitting body, supplied with nut and olive, see "15-DIGIT PRODUCT CODE"	
Plug with visual indication and peak voltage suppression or with cable length of 2 m (see Solenoids, Coils & Accessories section)	
Explosionproof enclosures for use in zones 1/21-2/22, categories 2-3 to ATEX Directive 2014/34/EU (See page 4)	

(*) Ensure that the compatibility of the fluids in contact with the materials is verified.

⁽²⁾ The minimum ambient temperature of the solenoid valve is determined by the limitations of minimum temperature indicated.

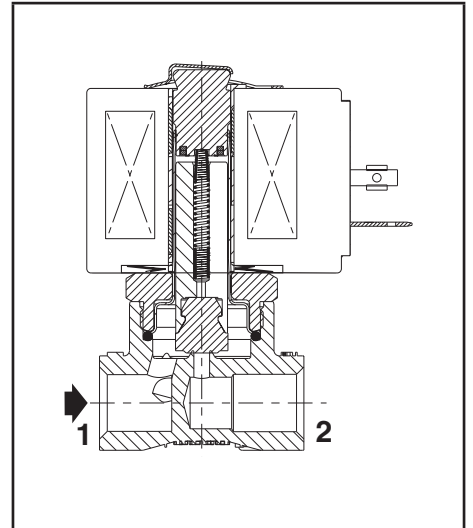

NC function

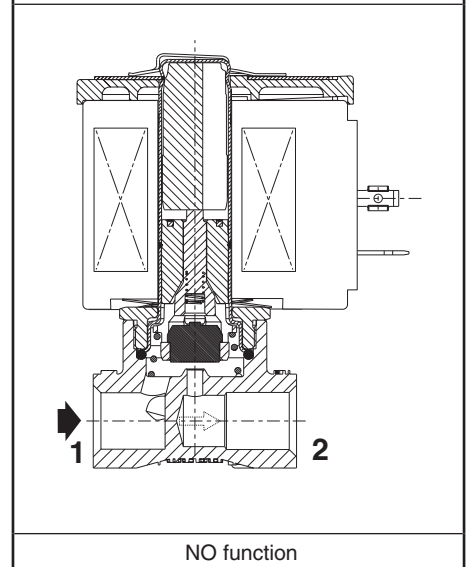

NO function

SPECIFICATIONS

pipe size	orifice size (mm)	flow coefficient Kv (m ³ /h)/(l/min)		operating pressure differential (bar) max. (PS)									power coil (W)		thread type	dimensions / type	15-DIGIT PRODUCT CODE		voltage code								
				min.			air (*)			water (*)							oil (*)			brass	stainless steel	24 V/50 Hz	48 V/50 Hz	115 V/50 Hz	230 V/50 Hz	24 V/DC	48 V/DC
				~	=	~	~	=	~	=	~	=					~	=									
				~	=	~	~	=	~	=	~	=					~	=									
WITHOUT MANUAL OPERATOR																											
NC - Normally closed, NBR seal and disc																											
1/8	1,2	0,05	0,8	0	51	51	51	41	50	34	8,1	10,6	G 01	01	G262K001S1N00	-	FL	FR	FT	F8	H1	H9					
														NPT 01	01	-							8262K012S1N00				
		2,4	0,18	3	0	25	14	22	10	13	10	8,1	10,6	G 01	01	G262K014S1N00							-				
													NPT 01	01	-	8262K015S1N00											
	3,2	0,3	5	0	12	8	12	6,5	8	6	8,1	10,6	G 01	01	G262K002S1N00	-											
													NPT 01	01	-	8262K006S1N00											
					18	10	17	8	13	8	11,1	18,6	G 01	01	G262K016S1N00	-											
					103	68	103	66	103	58	10,1	11,6	G* 02	02	E262K200S1W00 ⁽²⁾	-											
					151	68	151	66	117	58	10,1	11,6	G* 02	02	-	E262K214S1W00 ⁽²⁾											
													NPT 02	02	-	8262K214S1W00 ⁽²⁾											
					51	51	51	41	50	34	8,1	10,6	G* 01	01	E262K019S1N00	-											
													NPT 01	01	-	8262K080S1N00											
1/4	1,2	0,05	0,8	0	25	14	22	10	11	10	8,1	10,6	G* 01	01	E262K020S1N00	-											
																NPT 01	01	-	8262K086S1N00								
					34	19	24	13	18	13	11,1	18,6	G* 01	01	E262K021S1N00	-											
																	NPT 01	01	-	8262K086S1N00							
					40	16	28	16	28	15	10,1	11,6	G* 02	02	E262K108S1N00	E262K182S1N00											
																	NPT 02	02	-	8262K182S1N00							
	2,4	0,18	3	0	49	41	28	28	28	27	17,1	22,6	G* 02	02	E262K109S1N00	E262K183S1N00											
																NPT 02	02	-	8262K183S1N00								
					12	8	12	6,5	6	5,5	8,1	10,6	G* 01	01	E262K022S1N00	-											
																	NPT 01	01	-	8262K007S1N00							
					18	10	17	8	10	7,5	11,1	18,6	G* 01	01	E262K023S1N00	-											
																	NPT 01	01	-	8262K007S1N00							
3,2	0,3	5	0	23	7,5	20	7	14	6,5	10,1	11,6	G* 02	02	E262K232S1N00	E262K184S1N00												
															NPT 02	02	-	8262K184S1N00									
				34	17	26	17	24	15	17,1	22,6	G* 02	02	E262K110S1N00	E262K185S1N00												
																NPT 02	02	-	8262K185S1N00								
				14	3,5	13	3,5	10	3,5	10,1	11,6	G* 02	02	E262K202S1N00	E262K220S1N00												
																NPT 02	02	-	8262K220S1N00								
4	0,45	7,5	0	20	7,5	14	7,5	14	7,5	17,1	22,6	G* 02	02	E262K112S1N00	E262K187S1N00												
															NPT 02	02	-	8262K187S1N00									
				6,5	2	6,5	2	6,5	2	10,1	11,6	G* 02	02	E262K208S1N00	E262K226S1N00												
																NPT 02	02	-	8262K226S1N00								
				8,5	4	8,5	4	8,5	4	17,1	22,6	G* 02	02	E262K114S1N00	E262K188S1N00												
																NPT 02	02	-	8262K188S1N00								
5,6	0,63	10,5	0	3,5	2	3,5	2	2,5	1,9	8,1	10,6	G* 01	01	E262K013S1N00	-												
															NPT 01	01	-	8262K036S1N00									
				2	1,6	2	1,5	2	1,3	8,1	10,6	G* 01	01	E262K090S1N00	-												
																NPT 01	01	-	8262K038S1N00								
				4	1,5	5	1,5	4	1,3	10,1	11,6	G* 02	02	E262K210S1N00	E262K189S1N00												
																NPT 02	02	-	8262K189S1N00								
7,1	0,76	12,7	0	6	3	6	3	6	3	17,1	22,6	G* 02	02	E262K212S1N00	E262K230S1N00												
															NPT 02	02	-	8262K230S1N00									
				79	44	62	33	55	22	10,1	11,6	G 02	02	G262K155S1W00 ⁽²⁾	G262K168S1W00 ⁽²⁾												
																NPT 02	02	-	8262K168S1W00 ⁽²⁾								
				51	44	51	38	51	27	10,1	11,6	G 02	02	G262K156S1N00	G262K169S1N00												
																NPT 02	02	-	8262K169S1N00								
1/8	2,4	0,18	3	0	18	11	15	9	12	6,5	10,1	11,6	G 02	02	G262K128S1N00	G262K236S1N00											
																	NPT 02	02	-	8262K236S1N00							
	3,2	0,3	5	0	11	6,5	10	6,5	8,5	4,5	10,1	11,6	G 02	02	G262K129S1N00	G262K237S1N00											
1/4	1,2	0,05	0,8	0	79	44	62	33	55	22	10,1	11,6	G* 02	02	E262K161S1W00 ⁽²⁾	E262K199S1W00 ⁽²⁾											
	2,4	0,18	3	0	18	11	15	9	12	6,5	10,1	11,6	G* 02	02	E262K260S1N00	E262K130S1N00											
3,2	0,3	5	0	11	6,5	10	6,5	8,5	4,5	10,1	11,6	G* 02	02	E262K261S1N00	E262K134S1N00												
4	0,47	7,8	0	6	4	6	3,5	4,5	3	10,1	11,6	G* 02	02	E262K262S1N00	E262K138S1N00												
5,6	0,72	12	0	3	2	3	1,7	2,5	1,7	10,1	11,6	G* 02	02	E262K263S1N00	E262K142S1N00												
7,1	0,83	13,8	0	2	1,3	2	1,1	2	1,1	10,1	11,6	G* 02	02	E262K264S1N00	E262K148S1N00												

(1) For dimensions, see drawing(s) for each construction type on the following page(s).

(*) Ensure that the compatibility of the fluids in contact with the materials is verified.

(2) UR disc only, fluid temperature 0°C to +60°C, no other elastomer can be used.

SPECIFICATIONS

													15-DIGIT PRODUCT CODE										
pipe size	orifice size (mm)	flow coefficient Kv (m ³ /h)(l/min)		operating pressure differential (bar)						power coil (W)		thread type	dimensions / type (1)	brass		stainless steel		voltage code					
				max. (PS)														24 V/50 Hz	48 V/50 Hz	115 V/50 Hz	230 V/50 Hz	24 V/DC	48 V/DC
				min.	air (*)		water (*)		oil (*)														
~	=	~	=	~	=	~	=	~	=	~	=												
WITH MAINTAINED MANUAL OPERATOR																							
NC - Normally closed, NBR seal and disc																							
1/4	2,4	0,18	3	0	40	16	28	16	28	15	10,1	11,6	G* 02	E262K108S1N01	E262K182S1N01	FL	FR	FT	F8	H1	H9		
					49	41	28	28	28	27	17,1	22,6	NPT 02	-	8262K182S1N01								
	3,2	0,3	5	0	23	7,5	20	7	14	6,5	10,1	11,6	G* 02	E262K109S1N01	E262K183S1N01								
					34	17	26	17	24	15	17,1	22,6	NPT 02	-	8262K183S1N01								
	4	0,45	7,5	0	14	3,5	13	3,5	10	3,5	10,1	11,6	G* 02	E262K232S1N01	E262K184S1N01								
					20	7,5	14	7,5	14	7,5	17,1	22,6	NPT 02	-	8262K184S1N01								
	5,6	0,63	10,5	0	6,5	2	6,5	2	6,5	2	10,1	11,6	G* 02	E262K110S1N01	E262K185S1N01								
					8,5	4	8,5	4	8,5	4	17,1	22,6	NPT 02	-	8262K185S1N01								
	7,1	0,76	12,7	0	4	1,5	5	1,5	4	1,3	10,1	11,6	G* 02	E262K202S1N01	E262K220S1N01								
					6	3	6	3	6	3	17,1	22,6	NPT 02	-	8262K220S1N01								
						6,5	2	6,5	2	6,5	2	10,1	11,6	G* 02	E262K112S1N01							E262K187S1N01	
						8,5	4	8,5	4	8,5	4	17,1	22,6	NPT 02	-							8262K187S1N01	
						4	1,5	5	1,5	4	1,3	10,1	11,6	G* 02	E262K208S1N01							E262K226S1N01	
						6	3	6	3	6	3	17,1	22,6	NPT 02	-							8262K226S1N01	
						4	1,5	5	1,5	4	1,3	10,1	11,6	G* 02	E262K114S1N01							E262K188S1N01	
						6	3	6	3	6	3	17,1	22,6	NPT 02	-							8262K188S1N01	
					4	1,5	5	1,5	4	1,3	10,1	11,6	G* 02	E262K210S1N01	E262K189S1N01								
					6	3	6	3	6	3	17,1	22,6	NPT 02	-	8262K189S1N01								
					4	1,5	5	1,5	4	1,3	10,1	11,6	G* 02	E262K212S1N01	E262K230S1N01								
					6	3	6	3	6	3	17,1	22,6	NPT 02	-	8262K230S1N01								

(1) For dimensions, see drawing(s) for each construction type on the following page(s).

(2) UR disc only, fluid temperature 0°C to +60°C, no other elastomer can be used.

(*) Ensure that the compatibility of the fluids in contact with the materials is verified.

15-DIGIT PRODUCT CODE

- **262 K 001 S1 N00 H1**

Thread connection

- G** = ISO 228/1 (1/8)
- E** = ISO 228/1 & ISO 7/1 (combination thread, G*)
- 8** = NPT (SAE 71051)
- H** = 15 mm compression fittings ⁽²⁾

Product series
262

Revision letter
K = Initial release

Valves version

Voltage - class

- FL** = 24 V / 50 Hz - class F
- FR** = 48 V / 50 Hz - class F
- FT** = 115 V / 50 Hz - class F
- F8** = 230 V / 50 Hz - class F
- H1** = 24 V DC - class H
- H9** = 48 V DC - class H

Options

Without manual operator

- N00** = NBR disc and seals
- V00** = FPM disc and seals
- VN0** = FPM disc and seals for Oxygen service
- EM0** = EPDM disc and seals, WRAS approved ⁽²⁾
- E00** = EPDM disc and seals
- J00** = CR disc and seals
- T00** = PTFE disc and seals ⁽¹⁾

⁽¹⁾ (Max. operating pressure limited to 75% of standard value)

With maintained manual operator

- N01** = NBR disc and seals
- V01** = FPM disc and seals
- VN1** = FPM disc and seals for Oxygen service
- E01** = EPDM disc and seals
- J01** = CR disc and seals

Electrical interface & explosion proof options

- S1** = With spade plug connector
- FN** = Aluminium enclosure, 1/2 NPT conduit, IECEX/ATEX
II 2G/D Ex d IIC T6..T4 Gb / Ex tb IIIC Db IP66/IP67, zone 1-21 (equivalent to [NF](#) prefix)⁽³⁾
- FT** = Aluminium enclosure, 20 mm conduit, IECEX/ATEX
equivalent to [NFET](#) prefix)⁽³⁾
- FS** = AISI 316L enclosure, 1/2 NPT conduit, IECEX/ATEX
II 2G/D Ex d IIC T6..T4 Gb / Ex tb IIIC Db IP66/IP67, zone 1-21 (equivalent to [WSNF](#) prefix)⁽³⁾
- FU** = AISI 316L enclosure, 20 mm conduit, IECEX/ATEX
II 2G/D Ex d IIC T6..T4 Gb / Ex tb IIIC Db IP66/IP67, zone 1-21 (equivalent to [WSNFET](#) prefix)⁽³⁾
- MV** = Steel enclosure, M20 cable gland, IECEX/ATEX
II 2G Ex e mb IIC Gb T3, II2D Ex tb IIIC Db IP66/IP67, zone 1-21 (equivalent to [EM](#) prefix)⁽³⁾
- MT** = Steel enclosure, 20 mm conduit, IECEX/ATEX
II 2G Ex e mb IIC Gb T3, II2D Ex tb IIIC Db, zone 1-21 (equivalent to [EMET](#) prefix)⁽³⁾
- MN** = Steel enclosure, 1/2 NPT conduit, IECEX/ATEX
II 2G Ex e mb IIC Gb T3, II2D Ex tb IIIC Db IP66/IP67, zone 1-21 (equivalent to [EMT](#) prefix)⁽³⁾
- MW** = AISI 316 enclosure, M20 cable gland, IECEX/ATEX
II 2G Ex e mb IIC Gb T3, II2D Ex tb IIIC Db IP66/IP67, zone 1-21 (equivalent to [WSEM](#) prefix)⁽³⁾
- MU** = AISI 316 enclosure, 20 mm conduit, IECEX/ATEX
II 2G Ex e mb IIC Gb T3, II2D Ex tb IIIC Db IP66/IP67, zone 1-21 (equivalent to [WSEMET](#) prefix)⁽³⁾
- MS** = AISI 316 enclosure, 1/2 NPT conduit, IECEX/ATEX
II 2G Ex e mb IIC Gb T3, II2D Ex tb IIIC Db IP66/IP67, zone 1-21 (equivalent to [WSEMT](#) prefix)⁽³⁾
- A7** = Moulded enclosure, epoxy encapsulated, integrated cable, IECEX/ATEX
II2G Ex mb IIC Gb T3(-)/T4(=), II2D Ex mb IIIC Db IP67, zone 1-21 (equivalent to [PV](#) prefix)⁽³⁾
- SG** = Moulded coil with connector, epoxy encapsulated, ATEX
II 3 D Ex tc IIIC T115°C Dc IP65X, zone 22 (equivalent to [SG](#) prefix)⁽³⁾

⁽²⁾ Check the online configurator for available versions on: www.asco.com

⁽³⁾ Search prefix in asco.com to get detailed technical information.

Please note that the valve pressure ratings with some of the ATEX enclosures will be reduced.

To obtain the correct pressure rating please check the landing pages of the ["2-Way Solenoid Valve DIN Configurator"](#).

SPARE PARTS KITS CODE (*)



	AC (-)										DC (=)									
	NBR	FPM	FPM (oxygen)	EPDM	EPDM (+WRAS)	CR	PTFE	NBR + UR		NBR	FPM	FPM (oxygen)	EPDM	EPDM (+WRAS)	CR	PTFE	NBR + UR			
E262K013/019/020/021/022/023/090	M200001	N00	V00	VN0	E00	EM0	J00	T00	-	M200005	N00	V00	VN0	E00	EM0	J00	T00	-		
E262K108/109/110/112/114	M200007	N00	V00	VN0	E00	EM0	J00	T00	-	M200007	N00	V00	VN0	E00	EM0	J00	T00	-		
E262K130	M200017	N00	V00	VN0	E00	EM0	J00	T00	-	M200033	N00	V00	VN0	E00	EM0	J00	T00	-		
E262K134	M200018	N00	V00	VN0	E00	EM0	J00	T00	-	M200033	N00	V00	VN0	E00	EM0	J00	T00	-		
E262K138/142/148/152	M200018	N00	V00	VN0	E00	EM0	J00	T00	-	M200034	N00	V00	VN0	E00	EM0	J00	T00	-		
E262K161	M200021	-	-	-	-	-	-	-	W00	-	-	-	-	-	-	-	-			
E262K182/183/184/185/187/188/189	M200008	N00	V00	VN0	E00	EM0	J00	-	-	M200008	N00	V00	VN0	E00	EM0	J00	-	-		
E262K200	M200007	-	-	-	-	-	-	-	W00	M200007	-	-	-	-	-	-	-	W00		
E262K202/208/210/212	M200007	N00	V00	VN0	E00	EM0	J00	T00	-	M200007	N00	V00	VN0	E00	EM0	J00	T00	-		
E262K214	M200008	-	-	-	-	-	-	-	W00	M200008	-	-	-	-	-	-	-	W00		
E262K220/226/230	M200008	N00	V00	VN0	E00	EM0	J00	-	-	M200008	N00	V00	VN0	E00	EM0	J00	-	-		
E262K232	M200007	N00	V00	VN0	E00	EM0	J00	T00	-	M200007	N00	V00	VN0	E00	EM0	J00	T00	-		
E262K260	M200015	N00	V00	VN0	E00	EM0	J00	T00	-	M200031	N00	V00	VN0	E00	EM0	J00	T00	-		
E262K261	M200016	N00	V00	VN0	E00	EM0	J00	T00	-	M200031	-	-	-	-	-	-	-	W00		
E262K262/263/264/265	M200016	N00	V00	VN0	E00	EM0	J00	T00	-	M200032	N00	V00	VN0	E00	EM0	J00	T00	-		
G262K001/002/014/016	M200001	N00	V00	VN0	E00	EM0	J00	T00	-	M200005	N00	V00	VN0	E00	EM0	J00	T00	-		
G262K128	M200016	N00	V00	VN0	E00	EM0	J00	T00	-	M200031	N00	V00	VN0	E00	EM0	J00	T00	-		
G262K129	M200016	N00	V00	VN0	E00	EM0	J00	T00	-	M200032	N00	V00	VN0	E00	EM0	J00	T00	-		
G262K155	M200021	-	-	-	-	-	-	-	W00	-	-	-	-	-	-	-	-			
G262K156	M200015	N00	V00	VN0	E00	EM0	J00	T00	-	M200031	N00	V00	VN0	E00	EM0	J00	T00	-		
G262K168	M200021	-	-	-	-	-	-	-	W00	-	-	-	-	-	-	-	-			
G262K169	M200017	N00	V00	VN0	E00	EM0	J00	T00	-	M200033	N00	V00	VN0	E00	EM0	J00	T00	-		
G262K199	M200021	-	-	-	-	-	-	-	W00	-	-	-	-	-	-	-	-			
G262K236	M200018	N00	V00	VN0	E00	EM0	J00	T00	-	M200033	N00	V00	VN0	E00	EM0	J00	T00	-		
G262K237	M200018	N00	V00	VN0	E00	EM0	J00	T00	-	M200034	N00	V00	VN0	E00	EM0	J00	T00	-		
8262K006/007/012/015/036/038	M200003	N00	V00	VN0	E00	EM0	J00	T00	-	M200005	N00	V00	VN0	E00	EM0	J00	T00	-		
8262K080/086	M200003	N00	V00	VN0	E00	EM0	J00	T00	-	M200005	N00	V00	VN0	E00	EM0	J00	T00	-		
8262K130	M200017	N00	V00	VN0	E00	EM0	J00	T00	-	M200033	N00	V00	VN0	E00	EM0	J00	T00	-		
8262K134	M200018	N00	V00	VN0	E00	EM0	J00	T00	-	M200033	N00	V00	VN0	E00	EM0	J00	T00	-		
8262K138/142/148/152	M200018	N00	V00	VN0	E00	EM0	J00	T00	-	M200034	N00	V00	VN0	E00	EM0	J00	T00	-		
8262K168	M200021	-	-	-	-	-	-	-	W00	-	-	-	-	-	-	-	-			
8262K169	M200017	N00	V00	VN0	E00	EM0	J00	T00	-	M200033	N00	V00	VN0	E00	EM0	J00	T00	-		
8262K182/183/184/185/187/188/189	M200008	N00	V00	VN0	E00	EM0	J00	-	-	M200008	N00	V00	VN0	E00	EM0	J00	-	-		
8262K199	M200021	-	-	-	-	-	-	-	W00	-	-	-	-	-	-	-	-			
8262K220/226/230	M200008	N00	V00	VN0	E00	EM0	J00	-	-	M200008	N00	V00	VN0	E00	EM0	J00	-	-		
8262K236	M200018	N00	V00	VN0	E00	EM0	J00	T00	-	M200033	N00	V00	VN0	E00	EM0	J00	T00	-		
8262K237	M200018	N00	V00	VN0	E00	EM0	J00	T00	-	M200034	N00	V00	VN0	E00	EM0	J00	T00	-		

(*) Ensure that the compatibility of the fluids in contact with the materials is verified.

MAGNETIC LATCHING VERSION

fluids (*)	temperature range (TS)	seal materials (*)
water	0°C to +85°C	EPDM

ELECTRICAL CHARACTERISTICS

Coil insulation class	F (DC)
Standard voltages	DC (=) : 3V - 6V - 9V - 12V

operator ambient temperature range (TS) (°C)	power ratings		replacement coil ⁽¹⁾	
	hot/cold =		=	
	(W)			
	640	641/642/643/644	6 V DC	12 V DC
0 to +40	2,5	-	400927-003	400927-005
	-	6	400927-007	400927-014

⁽¹⁾ All coils 400 series are not UL & CSA approved.

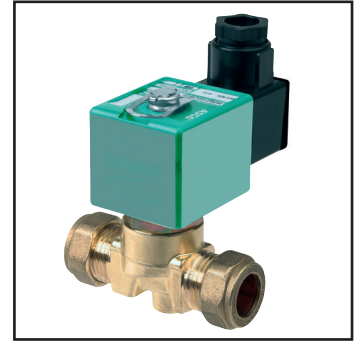

SPECIFICATIONS

pipe size	orifice size (mm)	flow coefficient Kv (m³/h) (l/min)		operating pressure differential (bar)		power coil (W)	thread type	dimensions / type ⁽²⁾	15-DIGIT PRODUCT CODE									
				max. (PS)					brass	voltage code								
				water (*)						3 V/DC	6 V/DC	9 V/DC	12 V/DC	24 V/DC				
WITHOUT MANUAL OPERATOR																		
EPDM seal and disc																		
15 mm compression fittings	1,2	0,05	0,8	0	10	2,5	H	03	H262K640S1EM0									
	2,0	0,15	2,5	0	10	6	H	03	H262K641S1EM0									
	3,2	0,30	5,0	0	3	6	H	03	CD	E7	E8	F3	F1					
	4	0,45	7,5	0	2	6	H	03						H262K642S1EM0				
	6,7	0,82	13,7	0	0,7	6	H	03						H262K643S1EM0				
					H262K644S1EM0													

⁽²⁾ For dimensions, see drawing(s) for each construction type on the following page(s).

(*) Ensure that the compatibility of the fluids in contact with the materials is verified.

15-DIGIT PRODUCT CODE FOR MAGNETIC LATCHING VERSION ONLY

[Configurator - CAD Files](#)

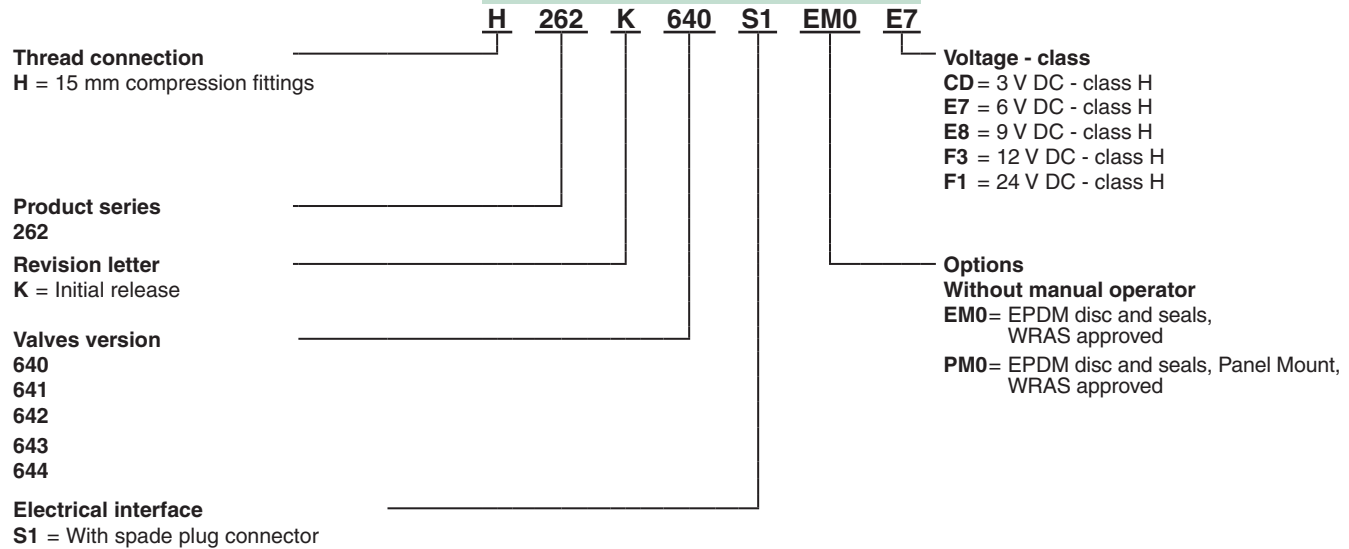

SPARE PARTS KITS CODE (*)

		DC (=)	
		EPDM (+ WRAS)	
	H262K640 / H262K641	M200001	EM0
	H262K642 / H262K643		
	H262K644		

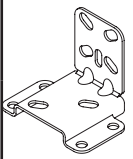
		ACCESSORIES CODE
	Mounting bracket Steel version (AISI 1010 / 1.1121)	M200094A00
	Mounting bracket Stainless steel version (AISI 304 / 1.4301)	M200095A00

INSTALLATION

- The solenoid valves can be mounted in any position without affecting operation
- Solenoid valves have 2 mounting holes in body
- Thread connection “E” applicable for 1/4 have standard thread according to ISO 228/1 and ISO 7/1. Thread connection “G” applicable for 1/8, have standard thread according to ISO 228/1
- Thread connection “8” have standard thread = NPT (SAE 71051)
- Thread connection “H” have 1/2” male ‘G’ thread according to BS 2779 plus cap-nut and olive
- Installation/maintenance instructions are included with each valve

DIMENSIONS (mm), WEIGHT (kg)

[Configurator - CAD Files](#)



TYPE 01

Electrical interface “S1”
Epoxy moulded
IEC 335 / ISO 4400
IP65

1/8, power coil 8,1 W / 10,6 W and 11,1 W / 18,6 W

1/4, power coil 8,1 W / 10,6 W and 11,1 W / 18,6 W

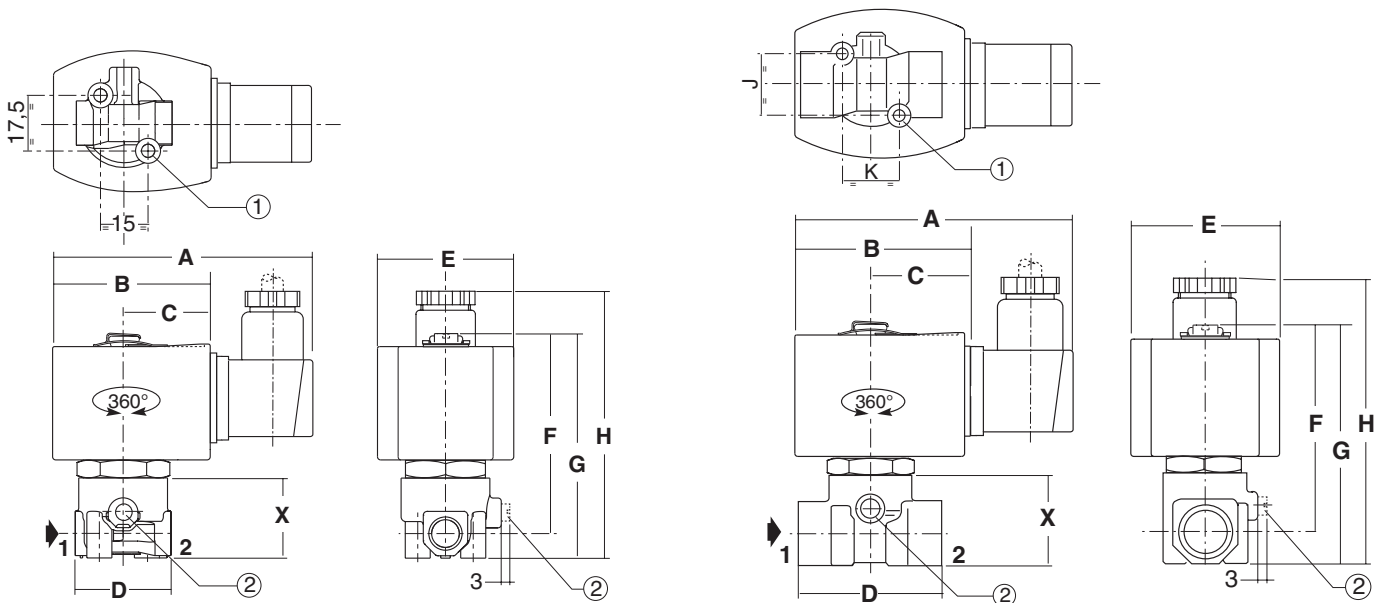

type	pipe size	A	B	C	D	E	F	G	H	X	weight ⁽¹⁾
01	1/8	88	51	30	30	43	62	71	88	26	0,30
	1/4	88	51	30	40	43	65	75	92	30	0,42

- ① 2 mounting holes:
M5 dia., depth 6,5 mm (1/8)
M5 dia., depth 7,5 mm (1/4)

- ② Manual operator location

⁽¹⁾ Incl. coil(s) and connector(s).

DIMENSIONS (mm), WEIGHT (kg)

[Configurator - CAD Files](#)



TYPE 02
 Electrical interface "S1"
 Epoxy moulded
 IEC 335 / ISO 4400
 IP65

NC: 1/4, power coil 10,1 W / 11,6 W and 17,1 W / 22,6 W

NO: 1/8-1/4, power coil 10,1 W / 11,6 W

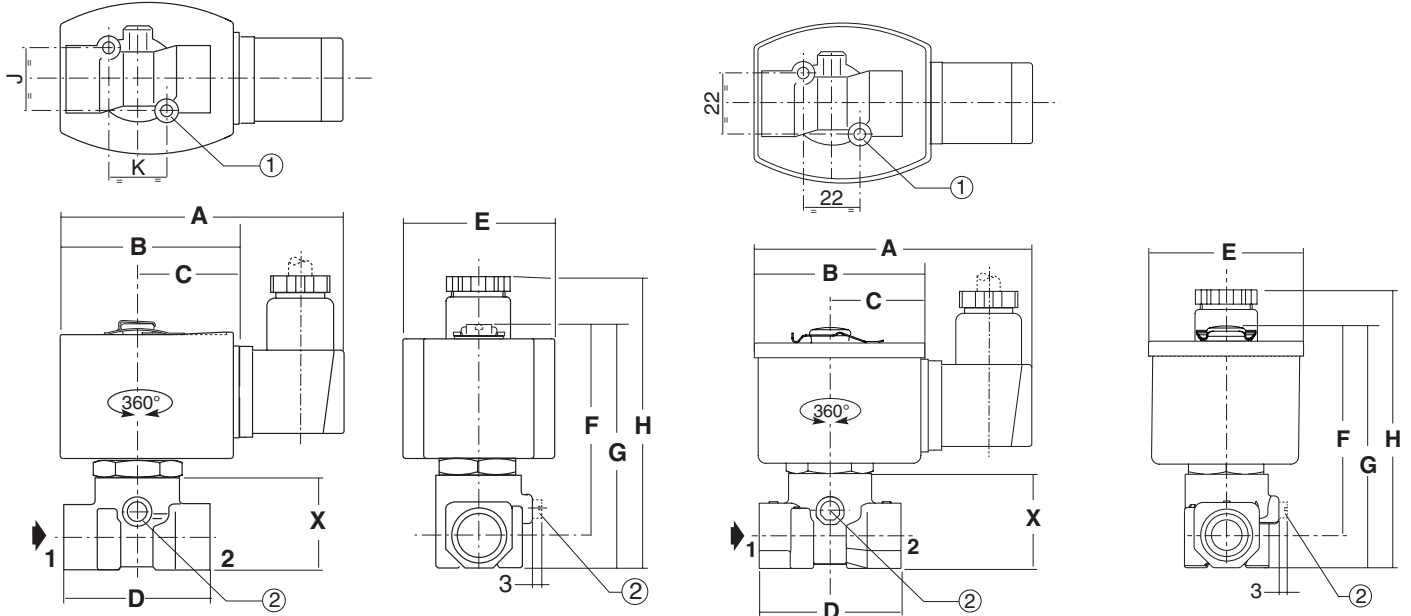

type	pipe size	A	B	C	D	E	F	G	H	J	K	X	weight ⁽¹⁾
02	1/8 (NO)	96	59	34	30	52	67	75	88	17,5	15	26	0,50
	1/4 (NC)	95	57	33	40	50	69	78	96	22	22	30	0,60
	1/4 (NO)	96	59	34	40	52	69	78	96	22	22	30	0,62

- ① 2 mounting holes:
M5 dia., depth 7,5 mm (1/4)
- ② Manual operator location.

⁽¹⁾ Incl. coil(s) and connector(s).



TYPE 03
 Electrical interface "S1"
 Epoxy moulded
 IEC 335 / ISO 4400
 IP65

Magnetic latching coil 2,5 W / 6 W

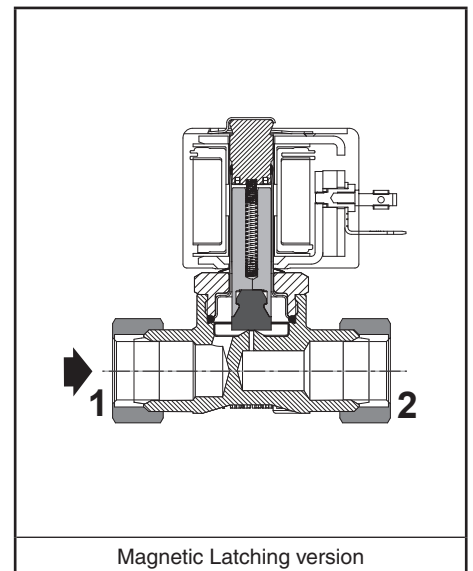
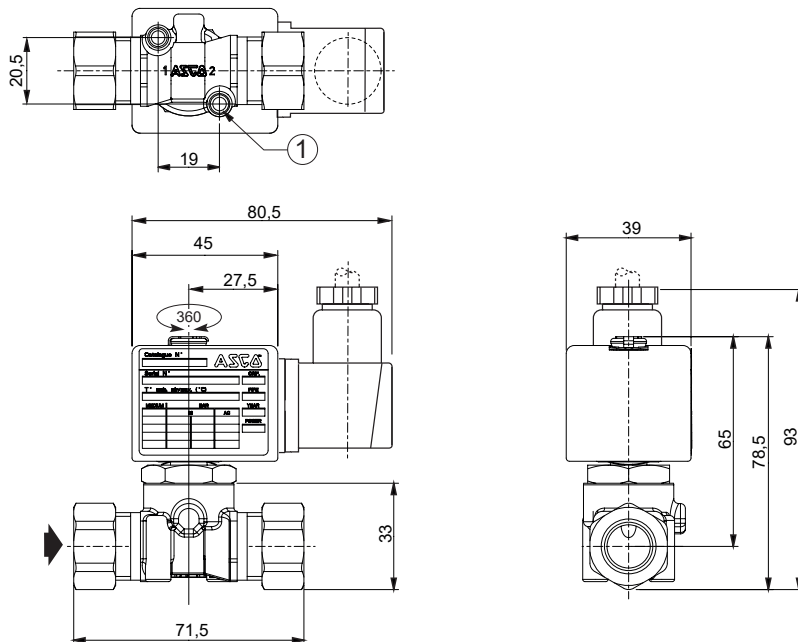

- ① 2 mounting holes:
190-24 UNC-2B, depth 6 mm

weight ⁽¹⁾
0,45

⁽¹⁾ Incl. coil(s) and connector(s).

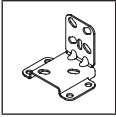

Mounting bracket
Steel or stainless steel

M200094A00 / M200095A00

