

244LVP *Levelstar* Intelligent Buoyancy Transmitter for Liquid Level, Interface and Density - Communication HART and Foundation Fieldbus -



The intelligent transmitter 244LVP is designed to perform continuous measurements for liquid level, interface or density of liquids in the process of all industrial applications. The measurement is based on the proven Archimedes buoyancy principle and thus extremely robust and durable. Measuring values can be transferred analog and digital. Digital communication facilitates complete operation and configuration via PC or control system. The 244LVP measures with consistent reliability and high precision. For installations in contact with explosive atmospheres up to Zone 0, certificates are available. The 244LVP combines the abundant experience of FOXBORO ECKARDT with most advanced digital technology.

FEATURES

- HART Communication, 4 to 20 mA, or FOUNDATION Fieldbus
- Configuration via FDT-DTM
- Multilingual full text graphic LCD
- IR communication as a standard
- Easy adaptation to the measuring point without calibration at the workshop
- Linear or customized characteristic with 32 points
- Approved for SIL applications (with HART)
- Local display in %, mA or physical units
- Signal noise suppression by Smart Smoothing
- Continuous self-diagnostics
- Linear or customized characteristic
- Process temperature from $-50\text{ }^{\circ}\text{C}$ to $+150\text{ }^{\circ}\text{C}$
- Static pressure up to PN 150, class 900
- Micro sintermetal sensor technology

Foxboro[®]
by **Schneider Electric**

TECHNICAL DATA

Data refer to the sensor material Type 316L (1.4404)

Explosion protection certificates must be observed!

Input / Output

Measuring ranges 50 mm to 15 m, upper and
lower range value continuously adjustable

Standard lengths of

Displacer (204DE) 300 .. 3000 mm, 12 .. 118 in;
further lengths on request

	PN 40	PN 40 (> 2.5 kg), PN 150
Weight force lower range value	25 N	40 N
Weight force upper range value	5 N	5 N
Measuring span	2 .. 20 N	3.4 .. 34 N
on request		2 N

Span ratio

Turn-down 1:1 .. 1:10 (1:20 on request)

Accuracy ¹⁾ $\pm 0.2\%$; increased accuracy
with customized adjustment

Transfer function linear or customized with up
to 32 setpoints

Configuration

- with FDT-DTM per HART protocol
 - via 2-wire connection 4 .. 20 mA
 - via IR communication
- with multi-lingual, full graphic LCD display with %, mA,
physical units and 2 from the outside-to-use buttons

Load $R_{Bmax} = (U_S - 12 V) / 23 mA$

Communication HART

Connection Two-wire system

Supply voltage U_S ²⁾ $> 12 V + R_b \cdot 0.024 A$

R_b is the total burden resistor for lines, HART measurement resistor and communication.

Current sink max. 24 mA

Signal range 4 to 20 mA

Operating range 3.8 to 20.5 mA (acc. NE 43)

Critical error alarms in the

2-wire Communication $< 3.6 mA$ and $> 21 mA$

HART Protocol

- 2-wire 1200 Baud, HART compliant
- IR communication 19200 Baud

Communication Hardware

- Handterminal HT 375/475
- PC Software WIN xx and FDT/DTM

Communication FOUNDATION Fieldbus H1

Connection twisted and shielded two wire
cable acc.to recommendation based on IEC 1158-2

Supply voltage U_S : 9 .. 30 V DC ³⁾, $V_{pp} \leq 1\%$

Operating current $10.5 mA \pm 0.5 mA$
(base current)

Digital communication FF specification ITK Profile 6,
Link-Master (LAS), funktion blocks 2AI, PID, IS, OS, AR

Signal amplitude $\pm 8 mA$

Fault current $\leq 13 mA$

Operating values according to IEC 1158-2

Bus connection Fieldbus interface based on
IEC 1158-2

Power supply Power supply is achieved de-
pendant on the application by means of segment coupler

File the actual file can be down-
loaded from our homepage

Configuration

Software National Instruments
NI-FBUS Configurator

Hardware FBUS interfaces from

National Instruments (USB-FBUS and PCMCIA-FBUS)

Control systems FOUNDATION Fieldbus H1
compatible

Failure handling

Substitute value last value or safety value

Safety value adjustable -110 .. +110 % of out

Reset substitute value automatically or manual

1) Accuracy acc. ANSI / ISA - S51.1 - 1979

2) U_S (max) with explosionproof device $< 30 V$, otherwise $< 42 V$

3) With explosionproof device 9 .. 24 V DC

Operating conditions ¹⁾

Process temperature -50 °C ... +150 °C
 Pressure rating
 acc. to DIN PN 16, 40, 63, 100, 150
 acc. to ANSI Class 150, 300, 600, 900
 Ambient temperature ²⁾ -40 °C ... +70 °C ³⁾
 Relative humidity up to 100 %
 Condensation permitted
 Transportation-
 storage temperature -40 °C ... +85 °C
 Protection IP 66 (acc. DIN 40 050)
 The device can be operated at a class D2 location in
 accordance with DIN IEC 654, part 1.

Operation condition effects

Ambient temperature -10 °C ... +70 °C
 Zero < 0.1 % / 10 K ⁴⁾
 Span < 0.07 % / 10 K
 Total

$$\left(0.1 \frac{\text{max. sp.}}{\text{adjusted sp.}} \pm 0.07 \frac{\text{measured value}}{\text{adjusted sp.}}\right) \% / 10\text{K}$$
 (sp. = measuring span)
 < -10 °C / > +70 °C twice the value
 Process temperature < 0.1 % / 10 K ⁹⁾
 Operating pressure no influence (vacuum resistant)

Transitional behavior

Dynamic behavior
 Damping (90 %-time) 0 ... 32 s
 Switch-on time 7 s
 Step response (63 %-time)
 with damping 0 s 250 ms
 Update rate 10 / s
 Long term stability < 0.2 % / 6 months at 20°C ⁹⁾
 Noise suppression
 Common mode voltage < AC 250 V_{eff}
 Common mode rejection 120 dB
 Series mode rejection 50 dB
 Filter Smart Smoothing

1) Not with all materials - see Table of Comparison of Materials page 6
 2) -50 °C on request
 3) Display not readable at T < -20 °C or T > +70 °C
 4) For max. measuring span

Materials (Table of Comparison see page 6)

Sensor	
Measuring cell	316L (1.4404 / 1.4435)
Fill fluid	silicone oil
Filling volume	approx. 0.3 cm ³
Displacer 104DE	316L (1.4404 / 1.4435), PTFE, PTFE with 25% carbon or Hastelloy C
Suspension	316L (1.4404 / 1.4435 / 1.4436)
Connection flange	316Ti (1.4571) (other on request)
Amplifier housing	Aluminium (Alloy No GD-Al Si 12), Polyurethan coated, or Stainless Steel 316L (1.4404)
For Sour Gas applications according to NACE Standard MR-0175-2003:	
Diaphragm	316L (1.4404 / 1.4435)
Flange	316Ti (1.4571)

Mounting

Mounting method	flange mounted
acc. DIN	DN 50, DN 80, DN 100
acc. ANSI	2 inch, 3 inch, 4 inch

Weight

Transmitter	see table page 6
Displacer	see table page 10

Electrical connection

Cable entry thread	M20x1.5 or 1/2-14 NPT
Cable gland and screwed sealing plug	have to be ordered separately under model code BUSG ...
For equipment in Ex d version,	1 screwed sealing plug made of stainless steel is included in delivery.
Screw terminals	wire cross-section up to 2.5 mm ²
Test sockets	Ø 2 mm

Electromagnetic compatibility EMC

Operating conditions	industrial environment, measuring instruments, living area
Immunity and Emission according to	
EN 55011 / IEC - CISPR 11	2011-4 fulfilled
EN / IEC 61000-4-2, 3, 4, 5, 6, 11	2011-9 fulfilled
EN / IEC 61000-6-2, 3, 4	2011-9 fulfilled
EN / IEC 61326-1	2006-10 fulfilled
NAMUR recommendation NE 21	2012 fulfilled

SAFETY REQUIREMENTS**CE Label**

Electromagnetic compatibility	2004/108/EG
Low-voltage regulation	not applicable
Explosion protection acc to ATEX	94/9/EG

Safety

According to EN 61010-1 (resp. IEC 1010-1)	safety class III
Internal fuses	none (or not replaceable by customer)
External fuses	Limitation of power supplies for fire protection have to be observed due to EN 61010-1, appendix F (rsp. IEC 1010-1)

Electrical classification ATEX ^{1) 2)}**Explosion-proof:**

AD 931	Housing	II 2 G Ex d IIC T6 Gb	PTB 02 ATEX 1025 X	Zone 1
--------	---------	-----------------------	--------------------	--------

Intrinsic safe and auxiliary protection:

AID421	Housing	II 2 G Ex d ia IIC T6 Gb	PTB 04 ATEX 2011 X	Zone 1
--------	---------	--------------------------	--------------------	--------

Zone 2:

AID 421	HART electronics	II 3 G Ex ia/ib IIC T4 Gc	Manufacturer's Declaration	Zone 2
---------	------------------	---------------------------	----------------------------	--------

International Certificates**FM Certification ***

Intrinsically Safe

Nonincendive

Explosion proof

Dust-Ignitionproof / II, III / 1 / EFG / T6

- Further protection types of on request -

* pending

1) With appropriate order only

2) National requirements have to be observed

TABLE OF MATERIALS

Comparison of Material

Code	Wnr	DIN	Remarks	equivalent to
X6 CrNiMoTi 17 12 2	1.4571	17 440		~ ASTM Typ 316Ti
X2 CrNiMo 17 13 2	1.4404			ASTM Typ 316L
X2 CrNiMo 18 14 3	1.4435			
X5 CrNiMo 17 13 3	1.4436			
NiMo 16 Cr 15 W	2.4819	17 744	equivalent to Hastelloy C-276 VdTÜV - Wbl. 400	UNS N 12 276
GD - AISi 12	3.2582.05	17 007	Al - Diecasting	

Service Limits 244LVP

Nominal pressure		316 / 316L (1.4404 / 1.4571)		
		Max. operating pressure in bar at temperature in °C		
		-50 ... -10	-10 ... +50	+150
DIN	PN 40 DIN 2635	40	40	34
	PN 63	63	63	53
	PN 100	100	100	86
	PN 160	150	150	134
ANSI	Class 150	19	18	15
	Class 300	49	49	40
	Class 600	99	99	75
	Class 900	148	148	114

Table of Weights

Transmitter, with flange	Weight [kg]									
	DIN PN						ANSI Class			
	16	25	40	63	100	160	150	300	600	900
DN 50 / 2 inch	4.9	4.9	4.9	-	-	-	4.5	5.5	-	-
DN 80 / 3 inch	7.2	7.2	7.2	7.6	9.7	10.3	7.4	9.2	9.2	13.7
DN 100 / 4 inch	-	7.7	7.7	10.7	14.2	15.5	7.6	7.6	18.3	22.6

CONNECTIONS, OPERATIONAL ELEMENTS

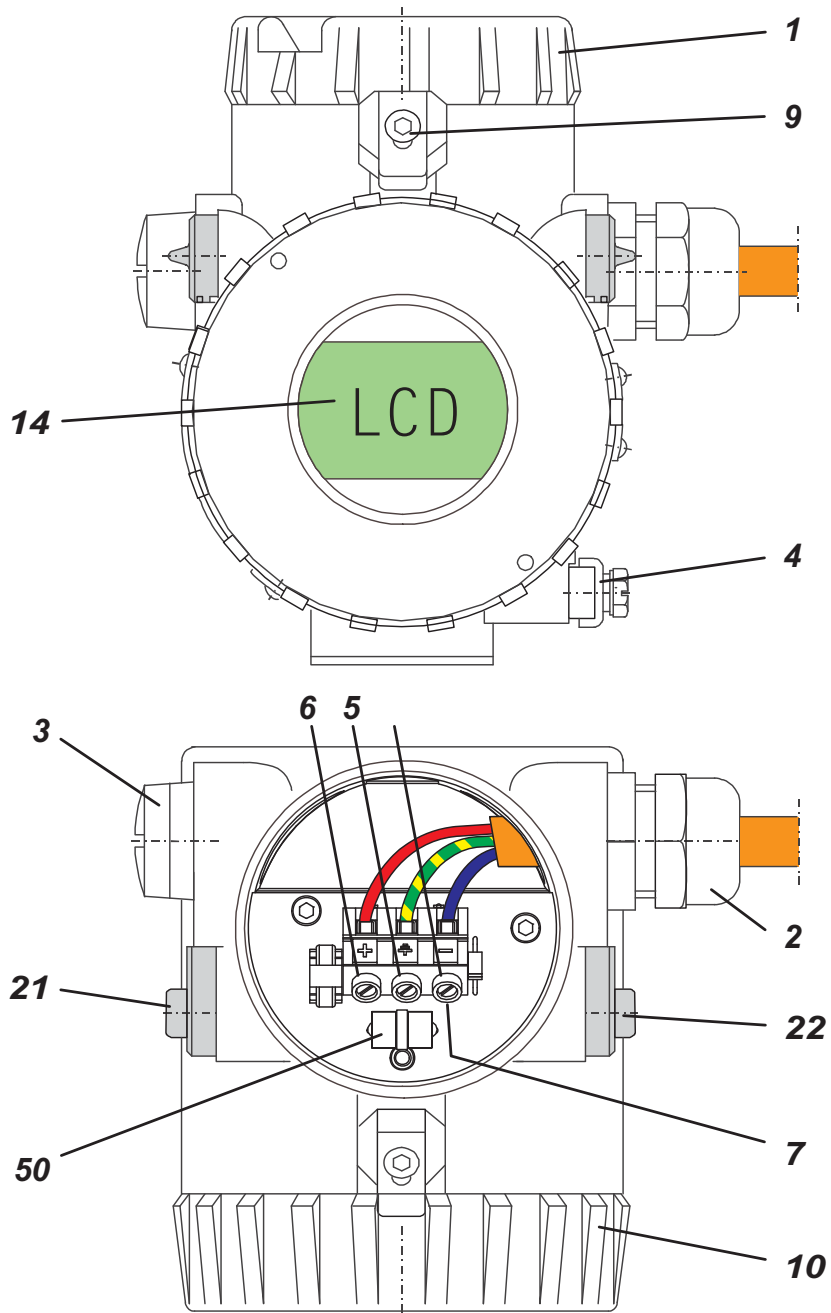

- 1 Cover for terminal compartment
- 2 Cable gland (as ordered)
- 3 Plug, interchangeable by Pos. 2
- 4 External ground connection
- 5 Internal ground connection
- 6 Terminals (+ / -)
- 7 Test sockets Ø 2 mm integrated in terminals
- 9 Security lock for Ex d version

- 10 Cover for amplifier housing (with local display)
- 14 LCD indicator shows
Measuring variable
Engineering unit and
Messages
- 21 Local key 1 for local operation
- 22 Local key 2 for local operation
- 50 Overvoltage protection

MODEL CODES 244LVP

Intelligent Buoyancy Transmitter with Displacer		244LVP							161014
Flange Material: (Process wettet)									
1.4571 (316Ti)									
Sensor Material: (Process Wetted)									
316L / 1.4435 / 1.4404									
Flange Size									
DN 50									
DN 80									
DN 100 (PN 25 / PN 40 only)									
2-Inch									
3-Inch									
4-Inch									
Flange Pressure Rating & Contact Face									
PN16 to PN40, B1 (DIN EN 1092-1)	(a)								B1
PN16 to PN40, B2 (DIN EN 1092-1)	(a)								B2
PN63, B2 (DIN EN 1092-1)	(r)								B3
PN100, B2 (DIN EN 1092-1)	(r)								B4
PN160, B2 (DIN EN 1092-1)	(r)								B5
PN16 to PN40, D (DIN EN 1092-1)	(a)								D1
PN63, D (DIN EN 1092-1)	(r)								D2
PN100, D (DIN EN 1092-1)	(r)								D3
PN160, D (DIN EN 1092-1)	(r)								D4
ANSI Class 150, RF RF/SF (RF125)	(b)								R1
ANSI Class 300, RF RF/SF (RF125)	(c)								R2
ANSI Class 600, RF RF/SF (RF125)	(s)								R3
ANSI Class 900, RF RF/SF (RF125)	(s)								R4
ANSI Class 150, RJF	(b)								J1
ANSI Class 300, RJF	(c)								J2
ANSI Class 600, RJF	(s)								J3
ANSI Class 900, RJF	(s)								J4
Version									
Base Version LEVELSTAR									N
Cable Entry									
M20x1.5 without Cable Gland									M
1/2-14 NPT without Cable Gland									N
Communication									
HART									H
FOUNDATION Fieldbus H1	(o)								B
Electrical Classification									
ATEX intrinsic safe, Zone 1 - IIC T4									1C4
ATEX intrinsic safe, Zone 1 - IIC T6									1C6
ATEX intrinsic safe, Zone 2 - IIC T4									2C4
ATEX intrinsic safe, Zone 2 - IIC T6									2C6
ATEX intrinsic safe Zone 1 - IIB T6									D1B
ATEX explosionproof, Zone 1 - IIC T6									D1C
FM Nonincendive	(m)								NFM
FM Explosionproof	(d)								FDZ
GOST-R Intrinsically Safe Zone 1 - IIC T6									GA1
GOST-R Intrinsically Safe Zone 2 - IIC T6									GA2
GOST-R explosion proof Zone 1 - IIC T6									GD1
Nepsi Intrinsically Safe T6	(d)								NA6
Nepsi explosion proof	(d)								NDZ
Brasil Intrinsically Safe T6	(d)								BA6
Brasil explosion proof	(d)								BDZ

(continued on next page)

MODEL CODES 244LVP (continued)

Electrical Classification (cont'd)		
CSA Explosionproof	(m)(d)	CDZ
FM Intrinsically Safe	(m)	FAA
CSA Intrinsically Safe	(d)	CAA
For General Purpose Areas, not Explosionproof		ZZZ
OPTIONS		
Housing Complete Stainless Steel Without External Pushbuttons		-H
External Pushbuttons for Maintenance	(n)	-M
Interface measurement, Displacer >2.5 kg (5.5 lb)	(t)	-I
Tag No. Labeling		
Stainless Steel Label Fixed With Wire		-L
Stainless Steel Label Fixed On Amplifier		-F
Certificates		
EN 10204-2.1, Certificate Of Compliance		-1
EN 10204-2.2, Specific Test Report (Calibration)		-2
EN 10204-3.1, Inspection Certificate Of Process Wetted Metallic Material.		-3
Comply with NACE Standard MR-01-75	(e)(f)	-6
SIL 2 Certificate		-Q
Amplifier for selected code (244LVP-*****-X)	(n)	-X

- (a) Available with Flange Size 5, 8, 9
- (b) Available with Flange Size 2, 3, 4
- (c) Available with Flange Size 2, 3
- (d) Pending
- (e) Only with Sensor Material S
- (f) Restrictions concerning the limit of application for the used materials are considerable (NACE Standard MR-0175/2003, resp. ISO 15156-3)
- (i) Only with Electrical Classification 1C4, 1C6, D1B, D1C, 2C4, GA1, GA2, GD1, NA6, NDZ, BA6, BDZ, ZZZ
- (k) Pending for Version N 1C6, 1B6
- (m) Only Version N
- (n) Not with Options -H
- (o) With Electrical Classification D1B or ZZZ
- (r) Available with Flange Size 8, 9
- (s) Available with Flange Size 3, 4
- (t) Only with Flange Pressure and Contact Face: B1, B2, B3, B4, D1, D2, D3, J1, J2, J3, J4, R1, R2, R3, R4

Accessories for Transmitter 244LVP *LevelStar*: Displacer 204DE

Typical Dimensions and Weights for Density Ranges $\Delta\rho$ ¹⁾

Material	316L (1.4404 / 1.4435) ²⁾										PTFE / PTFE with 25 % C				Hastelloy C									
Code	-S (PN 100)				-T ³⁾ (PN 40 / 63)				-S (PN 250)				-S (PN 500)				-S (PN 100 / 160)							
Len. L	Density Range $\Delta\rho$																							
	250 ... 1500 kg/m ³					300 ... 600 kg/m ³					400 ... 2000 kg/m ³					200 ... 1500 kg/m ³					300 ... 1500 kg/m ³			
	\varnothing mm	Vol. cm ³	Wei. N	PN bar	\varnothing mm	Vol. cm ³	Wei. N	PN bar	ρ_{min} ⁴⁾ kg/m ³	\varnothing mm	Vol. cm ³	Wei. N	PN bar	\varnothing mm	Vol. cm ³	Wei. N	PN bar	\varnothing mm	Vol. cm ³	Wei. N	PN bar			
mm																								
350	60.3	1000	19	100	101.6	2840	38	40	460	42.4	500	18	250	62	1056	23	500	60.3	1000	18	100			
500	48.3	920	17	100	88.9	3100	43	63	580	42.4	710	24	250	51	1021	23	500	48.3	920	19	100			
750	42.4	1060	21	100	76.1	3410	44	63	545	33.7	670	21	250	42	1039	24	500	48.3	1370	27	100			
1000	33.7	890	17	100	60.3	2855	41	63	545	26.9	570	18	250	35	961	21	500	33.7	890	19	100			
1200	33.7	1070	20	100	60.3	3425	48	63	675	26.9	680	22	250	35	1153	25	500	33.7	1070	22	100			
1500	26.9	850	16	100	51	3065	39	63	460	21.3	540	17	250	30	1060	24	500	26.9	850	18	160			
1800	26.9	1020	19	100	42.4	2540	38	63	495	21.3	640	20	250	28	1107	25	500	26.9	1020	21	160			
2000	26.9	1140	21	100	42.4	2825	41	63	565	21.3	710	22	250	25	981	22	500	26.9	1140	23	160			
2500	21.3	890	20	100	38	2840	37	63	425	17.2	580	16	250	22.5	993	23	500	21.3	890	23	160			
3000	21.3	1070	24	100	38	3400	45	63	575	17.2	700	23	250	20	942	22	500	21.3	1070	27	160			
inch																								
14	60.3	1020	20	100	101.6	2885	38	40	455	42.4	510	18	250	62	1074	23	500	60.3	1020	18	100			
32	42.4	1150	23	100	76.1	3700	47	63	595	33.7	730	23	250	42	1126	26	500	33.7	720	16	100			
48	33.7	1090	20	100	60.3	3480	49	63	680	26.9	690	22	250	35	1171	26	500	33.7	1090	23	100			
60	26.9	870	16	100	51	3115	40	63	465	21.3	540	18	250	30	1076	24	500	26.9	870	18	100			
72	26.9	1040	19	100	42.4	2580	38	63	505	21.3	650	21	250	28	1124	26	500	26.9	1040	21	160			
84	26.9	1210	22	100	42.4	3000	44	63	635	21.3	760	23	250	25	1046	24	500	26.9	1210	25	160			
96	21.3	870	20	100	38	2765	37	63	420	17.2	570	16	250	22.5	968	22	500	21.3	870	23	160			
120	21.3	1090	25	100	38	3455	46	63	595	17.2	710	24	250	20	957	22	500	21.3	1090	25	160			

- $\Delta\rho = \rho_1 - \rho_2$
 ρ_1 = density of lower medium
 ρ_2 = density of upper medium
- Using displacer material 1.4571 can cause small deviations in diameter, volume and weight.
- For measurement of interface or density, the max. density of the lower medium is 1350 kg/m³.
- Min. density of the lower medium

If a Displacer Chamber is used, the difference between the diameter of the Displacer and the inside diameter of the Displacer Chamber must be at least 10 mm.

Lengths < 350 mm and > 3000 mm, and density ranges < 300 kg/m³ and > 2000 kg/m³ on request.

Accessories

For Displacer Chamber 204DC, Flange combination 204FK and Cover Flange Kit 204BCF see PSS EML0901, 204xx Accessories for Buoyancy Transmitter.

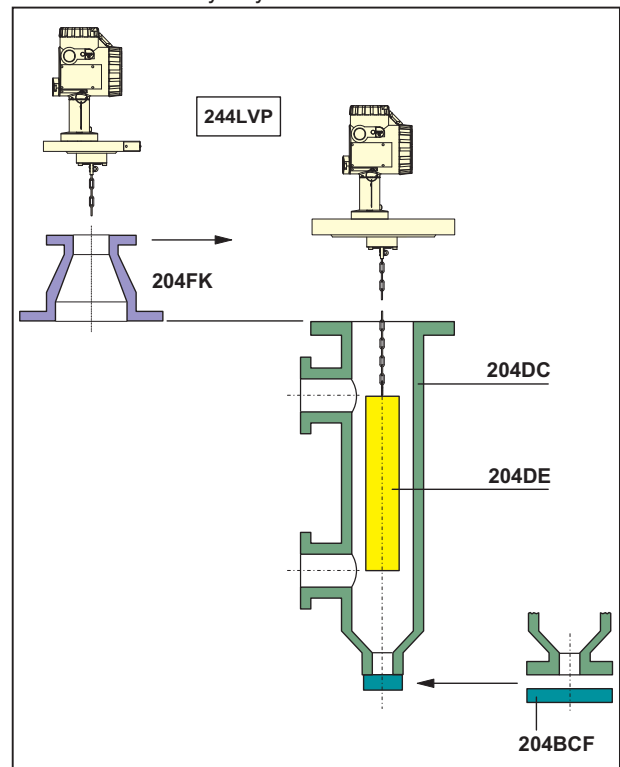

MODEL CODES 204DE

Displacer for Buoyancy Transmitters from 2N buoyancy up to 20N 204DE									210814
RANGE OF APPLICATION: (a)									
Liquid Level - Media: Liquid / Gas or Air									
(Density difference = 250 kg/m ³ to 2000 kg/m ³)									
(= 9x10 ⁻³ lbm/in ³ to 72.2x10 ⁻³ lbm/in ³) -S									
Interface Level / Density - Media: Liquid 1 / Liquid 2									
(Density difference = 300 kg/m ³ to 600 kg/m ³)									
(= 10.8x10 ⁻³ lbm/in ³ to 22.7x10 ⁻³ lbm/in ³) (g)(h) -T									
DISPLACER MATERIAL:									
316L (1.4404 / 1.4435 / 1.4571) S									
321 (1.4541) H									
PTFE (not for applications in Zone 0) P									
PTFE with 25% Carbon O									
Hastelloy C C									
Inconel 625 (2.4856) (e) R									
Monel 400 (2.4360) (e) M									
Titan (3.7035) (e) T									
PRESSURE RATING:									
Up to PN 100 / Class 600 D									
Up to PN 160 / Class 900 E									
Up to PN 250 / Class 1500 F									
Up to PN 500 / Class 2500 G									
SUITABLE FOR FLANGE SIZE: (at Top of vessel/chamber)									
DN 50 0									
DN 70 1									
DN 80 2									
DN 100 3									
DN 150 4									
2 inch 5									
3 inch 6									
4 inch 7									
6 inch 8									
DISPLACER LENGTH "L": (inches are approx.)									
for Displacer Material codes P and O:									
300 mm (12 in) to 2000 mm (79 in) without partitioning A									
2001 mm (79 in) to 4000 mm (157 in) One partition point B									
4001 mm (157 in) to 6000 mm (236 in) Two partition points C									
6001 mm (236 in) to 8000 mm (315 in) Three partition points D									
8001 mm (315 in) to 10000 mm (394 in) Four partition points E									
10001 mm (394 in) to 12000 mm (472 in) Five partition points F									
for Displacer Material S, H, C, R, M and T:									
300 mm (12 in) to 3000 mm (118 in) without partitioning K									
3001 mm (118 in) to 6000 mm (236 in) One partition point L									
6001 mm (236 in) to 9000 mm (354 in) Two partition points M									
9001 mm (354 in) to 12000 mm (472 in) Three partition points N									
12001 mm (472 in) to 15000 mm (591 in) Four partition points O									
MATERIAL AND LENGTH OF THE SUSPENSION: (Length "b") (d)									
316L / 1.4404 / ... Standard length of Suspension (b) S1									
316L / 1.4404 / ... Customized Suspension Length (c) S2									
321 / 1.4541 Standard length of Suspension (b) H1									
321 / 1.4541 Customized Suspension Length (c) H2									
Hastelloy C Standard length of Suspension (b) C1									
Hastelloy C Customized Suspension Length (c) C2									
Inconel Standard length of Suspension (b) I1									
Inconel Customized Suspension Length (c) I2									
Monel Standard length of Suspension (b) M1									
Monel Customized Suspension Length (c) M2									
Titan Standard length of Suspension (b) T1									
Titan Customized Suspension Length (c) T2									

(continued on next page)

MODEL CODES 204DE (continued)

OPTIONS:

For application in Zone 0 (Additional grounding rope) (not available with Displacer Material: P)	-E
Damping Spring (Mat. 1.4310, max. 250 °C (482 °F)) (f)	-D
Damping Spring (Mat. HC, max 350 °C (662 °F)) (f)	-C
Free of oil and fat.	-O
Density difference > 300 kg/m ³ (a)	-K
Tag No. Labeling Stainless Steel Label Fixed With Wire (Text required).	-L

Certificates

EN 10204-2.1 Certificate Of Compliance	-1
EN 10204-3.1 Inspection Certificate Of Process Wetted Material (not available with Displacer Material: P and O)	-3
PMI - Test (not available with Displacer Material: P and O)	-5

- (a) Upper and Lower Medium Density required (at operating temperature)
- (b) Only in connection with Modelcode 204DC
- (c) Exact length required (Contact face of flange to upper end of displacer)
- (d) +/- 8 mm (+/- 0.3 inch)
- (e) On ECEP request
- (f) Required for 244LD with Option -G
- (g) Only with PRESSURE RATING: D. Consult factory if pressure rating is F or G
- (h) Option K required

DIMENSIONS 244LVP with Displacer Element 204DE

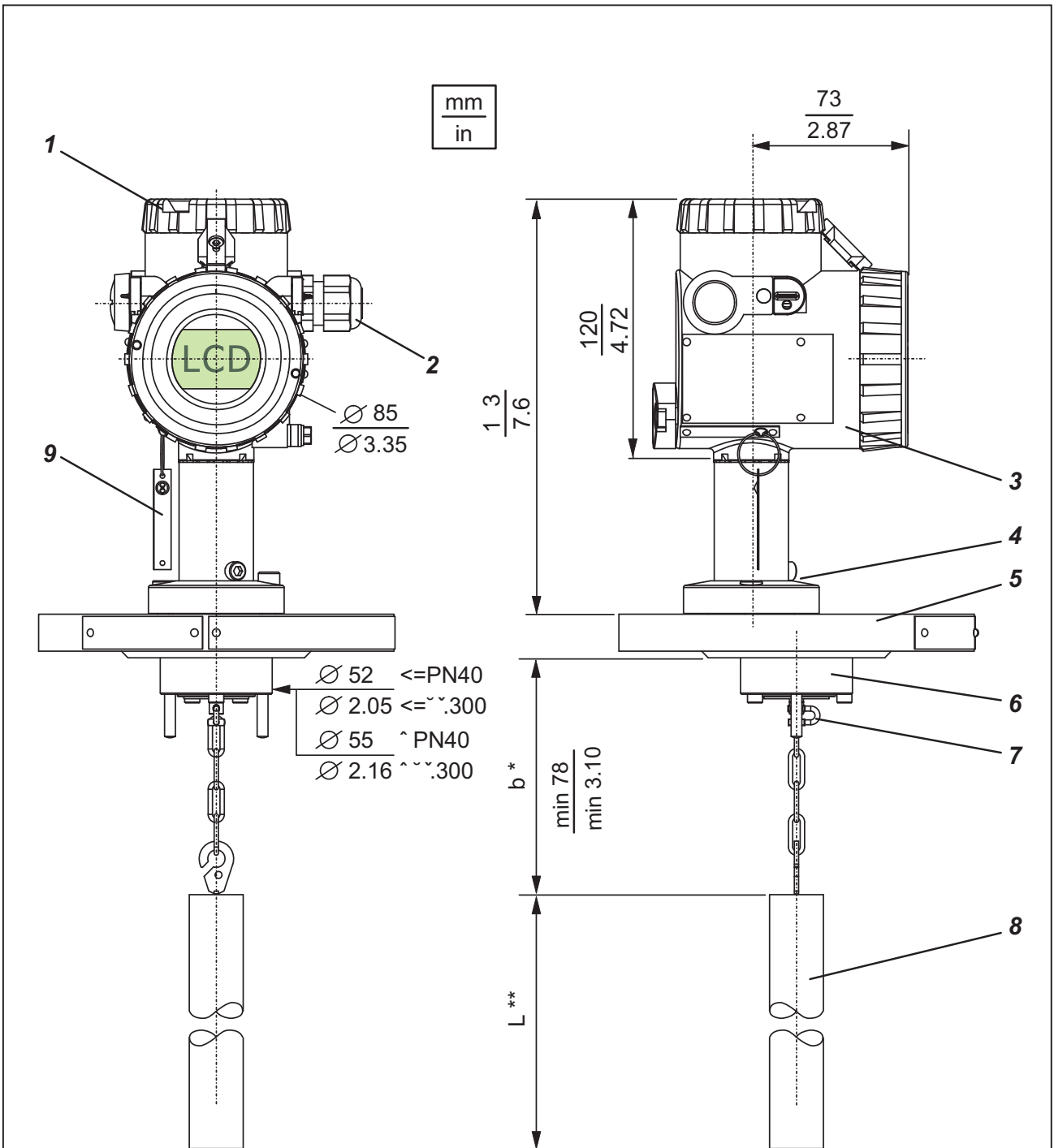

- 1 Connecting compartment cover
- 2 Cable entry with screwed gland
- 3 Amplifier housing
- 4 Disconnection of sensor from the amplifier
- 5 Connection flange (as per DIN / ANSI)
- 6 Measuring cell
- 7 Suspension
- 8 Displacer 204DE
- 9 Steel label with Tag.No.

* Suited to the dimensions of
FOXBORO ECKARDT - displacer,
other lengths on request

** L (measuring range) see table page 10.

Product Specifications for Intelligent Level Transmitters

Product Specification: Device:

LevelWave Radar Transmitters

[PSS EML3010](#) LG01 Guided Wave Radar Level Meter

[PSS EML3020](#) LR01 Free-Space Radar Level Meter

LevelStar Buoyancy Transmitters

[PSS EML0710](#) 244LD Intelligent Buoyancy Transmitter for Liquid Level, Interface and Density with Displacer and Torque Tube

[PSS EML1710](#) 244LVP Intelligent Buoyancy Transmitter for Liquid Level, Interface and Density with Displacer

[PSS EML0901](#) 204xx Accessories for Buoyancy Transmitters

Subject to alterations - reprinting, copying and translation prohibited. Products and publications are normally quoted here without reference to existing patents, registered utility models or trademarks. The lack of any such reference does not justify the assumption that a product or symbol is free.

FOXBORO ECKARDT GmbH
Pragstr. 82
D-70376 Stuttgart
Germany
Tel. +49 (0)711 502-0
Fax +49 (0)711 502-597
<http://www.foxboro-eckardt.com>

ECKARDT S.A.S.
20 rue de la Marne
F-68360 Soultz
France
Tel. + 33 (0)3 89 62 15 30
Fax + 33 (0)3 89 62 14 85

DOKT 556 882 022~1

