

## 244LD *Levelstar* Intelligent Buoyancy Transmitter for Liquid Level, Interface and Density, with Torque tube – Communication HART and Foundation Fieldbus –



The intelligent transmitter 244LD *LevelStar* is designed to perform continuous measurements for liquid level, interface or density of liquids in the process of all industrial applications. The measurement is based on the proven Archimedes buoyancy principle and thus extremely robust and durable. Measuring values can be transferred analog and digital. Digital communication facilitates complete operation and configuration via PC or control system. Despite extreme temperatures, high process pressure and corrosive liquids, the 244LD measures with consistent reliability and high precision. It is approved for installations in contact with explosive atmospheres. The 244LD *LevelStar* combines the abundant experience of FOXBORO ECKARDT with most advanced digital technology.

### FEATURES

- HART Communication, 4-20 mA, or Foundation Fieldbus
- Configuration via FDT-DTM
- Multilingual full text graphic LCD
- IR communication as a standard
- Easy adaptation to the measuring point without calibration at the workshop
- Linear or customized characteristic with 32 points
- Approved for SIL 2 applications (at HART)
- Backdocumentation of measuring point
- Continuous self-diagnostics, Status and diagnostic messages
- Configurable safety value
- Local display in %, mA or physical units
- Process temperature from  $-196\text{ }^{\circ}\text{C}$  to  $500\text{ }^{\circ}\text{C}$
- Materials for use with aggressive media
- Micro sintermetal sensor technology

# Foxboro®

by Schneider Electric

PACTware: Operation

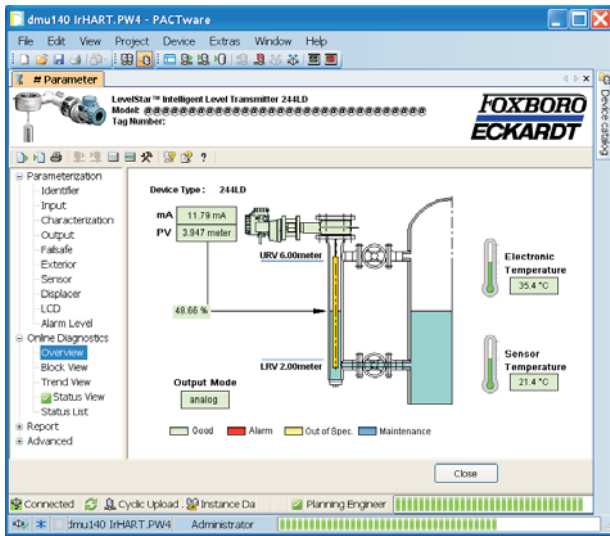

FDT-DTM: Configuration

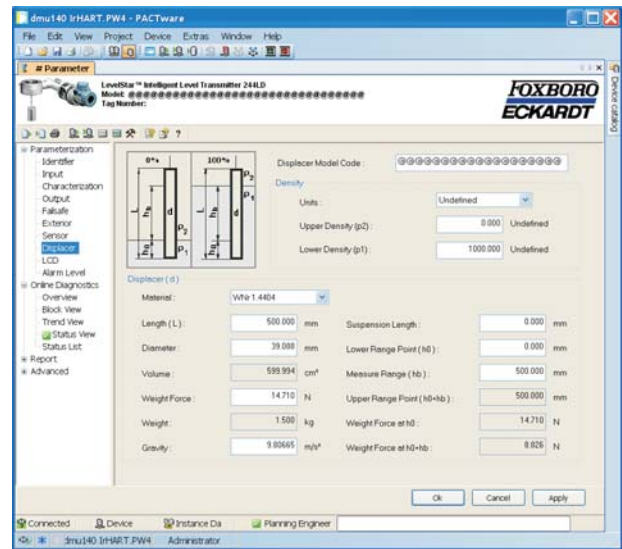

Supply via power supply unit with communication; Ex

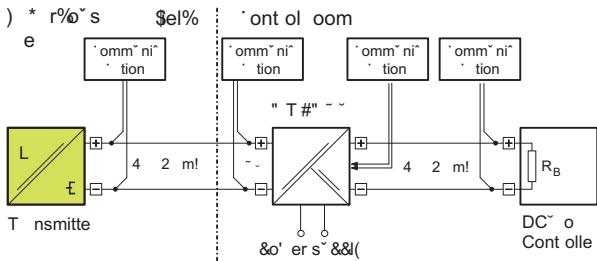

Direct supply with communication; not Ex

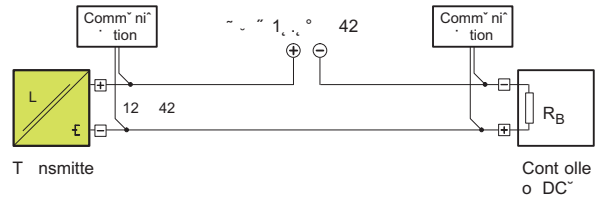

Further supply circuits see Master Instruction document.

CONNECTIONS, OPERATIONAL ELEMENTS

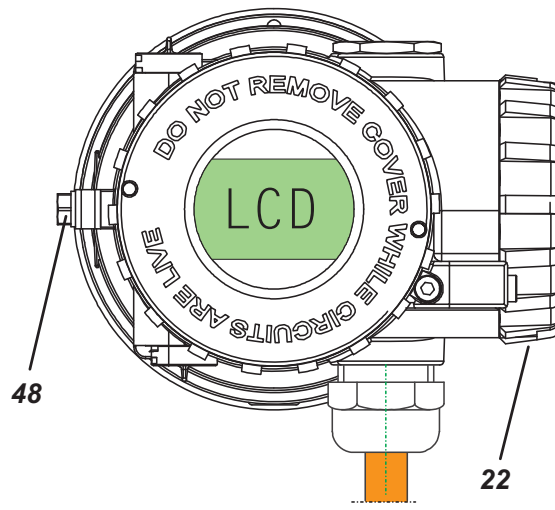
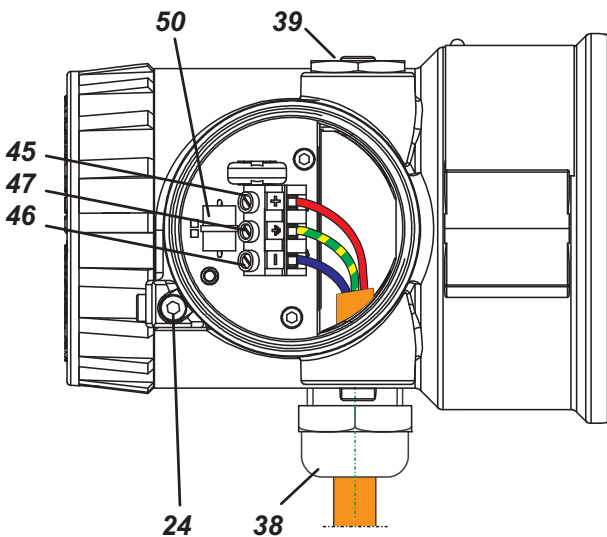

- 22 Cover for terminal compartment
- 24 Security lock, for Ex d version
- 38 Cable gland (for cable Ø 6 to 12 mm)
- 39 Plug
- 50 Overvoltage protection (if present)

- 45 Terminal "+" wire cross-section up to 2,5 mm<sup>2</sup>
- 46 Terminal "-"
- 47 Ground terminal Test sockets Ø 2 mm integrated in terminals
- 48 External ground connection

**TECHNICAL DATA**

Data refer to the sensor material Type 316L (1.4404)

Explosion protection certificates must be observed!

**Input / Output**

- Measuring ranges . . . . . 50 mm to 50 m, upper and lower range value continuously adjustable
- Standard lengths of Displacer (204DE) . . . . . 350 to 3000 mm, 14 to 120 in; further lengths on request
- Weight of displacer <sup>1)</sup> . . . . . max. 25 N
- Measuring span . . . . . 2 to 20 N contin. adjustable (to 1 N on request)
- Span ratio Turn-down . . . . . 1:1 to 1:10 (1:20 on request)
- Accuracy <sup>2)</sup> . . . . . ± 0.2 % at Level, Density and Interface measurement. Increased accuracy with customized adjustment.
- Transfer function . . . . . linear or customized with up to 32 setpoints

**Configuration**

- with FDT-DTM per HART protocol
  - via 2-wire connection 4-20 mA
  - via IR communication
- with multi-lingual, full graphic LCD display with %, mA, physical units and 2 from the outside-to-use buttons
- Load . . . . .  $R_{Bmax} = (U_S - 12 V) / 23 mA$

**Communication FOUNDATION Fieldbus H1**

- Connection . . . . . twisted and shielded two wire cable acc.to recommendation based on IEC 1158-2
- Supply voltage  $U_S$ : . . . . . 9 to 32 V DC <sup>3)</sup>,  $V_{pp} \leq 1\%$
- Operating current . . . . . 10.5 mA ± 0.5 mA (base current)
- Digital communication . . . . . FF specification ITK Profile 6, Link-Master (LAS), funktion blocks 2AI, PID, IS, OS, AR
- Signal amplitude . . . . . ± 8 mA
- Fault current . . . . . ≤ 13 mA
- Operating values . . . . . according to IEC 1158-2
- Bus connection . . . . . Fieldbus interface based on IEC 1158-2
- Power supply . . . . . Power supply is achieved dependant on the application by means of segment coupler
- File . . . . . the actual file can be downloaded from our homepage

**Configuration**

- Software . . . . . National Instruments NI-FBUS Configurator
- Hardware . . . . . FBUS interfaces from National Instruments (USB-FBUS and PCMCIA-FBUS)
- Control systems . . . . . FOUNDATION Fieldbus H1 compatible

**Failure handling**

- Substitute value . . . . . last value or safety value
- Safety value . . . . . adjustable -110 to 110 % of out
- Reset substitute value . . . . . automatically or manual

**Communication HART**

- Connection . . . . . Two-wire system
- Supply voltage  $U_S$  <sup>4)</sup> . . . . . > 12 V +  $R_b \cdot 0.025 A$   
 $R_b$  is the total burden resistor for lines, HART measurement resistor and communication.
- Current sink . . . . . max. 24 mA
- Signal range . . . . . 4 to 20 mA
- Operating range . . . . . 3.8 to 20.5 mA (acc. NE 43)
- Critical error alarms in the 2-wire Communication . . . . . < 3.6 mA and > 21 mA
- HART Protocol
  - 2-wire . . . . . 1200 Baud, HART compliant
  - IR communication . . . . . 19200 Baud
- Communication Hardware
  - Handterminal . . . . . HT 375/475
  - PC Software . . . . . WIN xx and FDT/DTM

**Operating conditions <sup>5)</sup>**

- Process temperature . . . . . -196 °C to 500 °C
- Pressure rating
  - acc. to DIN . . . . . PN 16, 40, 63, 100, 160, 250
  - acc. to ANSI . . . . . Class 150, 300, 600, 900, 1500
- Ambient temperature <sup>6) 7)</sup> . . . . . -40 °C ... 85 °C <sup>8)</sup>
- Relative humidity . . . . . up to 100 %
- Condensation . . . . . permitted
- Transportation-storage temperature . . . . . -40 °C to 85 °C
- Protection . . . . . IP 66 (acc. DIN 40 050)
- The device can be operated at a class D2 location in accordance with DIN IEC 654, part 1.

**Operation condition effects**

- Ambient temperature . . . . . -10 °C ... +70 °C
- Zero . . . . . < 0.1 % / 10 K <sup>9)</sup>
- Span . . . . . < 0.07 % / 10 K
- Total
  - $(0.1 \frac{\text{max. sp.}}{\text{adjusted sp.}} \pm 0.07 \frac{\text{measured value}}{\text{adjusted sp.}}) \% / 10K$
  - (sp. = measuring span)
  - < -10 °C / > +70 °C . . . . . twice the value
- Process temperature . . . . . < 0.1 % / 10 K <sup>9)</sup>
- Operating pressure . . . . . no influence (vacuum resistant)

**Transitional behavior**

- Dynamic behavior
  - Damping (90 %-time) . . . . . 0 to 32 s
  - Switch-on time . . . . . 7 s
  - Step response (63 %-time) with damping 0 s . . . . . 250 ms
- Update rate . . . . . 10 / s
- Long term stability . . . . . < 0.2 % / 6 months at 20°C <sup>9)</sup>
- Noise suppression
  - Common mode voltage . . . . . < AC 250  $V_{eff}$
  - Common mode rejection . . . . . 120 dB
  - Series mode rejection . . . . . 50 dB
  - Filter . . . . . Smart Smoothing

1) For measurement of interface or density: weight 25 N + buoyant force at lowest density  
 2) Accuracy acc. ANSI / ISA - S51.1 - 1979  
 3) With explosionproof device 9 to 24 V DC  
 4)  $U_S$  (max) with explosionproof device < 30 V, otherwise < 42 V

5) Not with all materials - see Table of Comparison of Materials page 6  
 6) Ambient temperature must not exceed 50 °C at measuring module housing, when process medium or heating of medium exceed 300 °C  
 7) -50 °C on request  
 8) Display not readable at  $T < -20 °C$  or  $T > 70 °C$   
 9) For max. measuring span

### Material, Pressure Rating & Contact Face, Mounting Direction

see Model Codes

Material Amplifier housing . . . Aluminium  
(Alloy No. GD-AI Si 12),  
Polyurethan coated  
or Stainless Steel

For Sour Gas applications acc. to NACE Standard MR-0175-95:  
Wafer body . . . . . 316L (1.4404)  
Torque tube . . . . . Hastelloy C or Inconel 600

The material of the seal at the Torque tube bearing corresponds to the material of the head piece.

### Mounting

Mounting method . . . . . sandwich mounted  
acc. to DIN . . . . . DN 80, DN 100  
acc. to ANSI . . . . . 3 inch, 4 inch

**Note:** Always follow the RH or LH version! See the picture below. The device can not be used "upside down". All internal parts are mounted and calibrated in inverse manner. The conversion can be performed only by the manufacturer or a contractual partner. Otherwise calibration and pressure test are invalid.

### Weight

Transmitter . . . . . see table page 7  
Displacer . . . . . see table page 10

### Electrical connection

Cable entry thread . . . . . M20x1.5 or 1/2-14 NPT  
Cable gland and screwed sealing plug have to be ordered separately under model code BUSG ...

For equipment in Ex d version, 1 screwed sealing plug made of stainless steel is included in delivery.  
Screw terminals . . . . . wire cross-section up to 2.5 mm<sup>2</sup>  
Test sockets . . . . . Ø 2 mm

### Electromagnetic compatibility EMC

Operating conditions . . . . . industrial environment  
Immunity according to  
EN 61326 (3/2002) . . . . . fulfilled  
Emission according to  
EN 61326 (3/2002) . . . . . fulfilled  
EN 55011, May 2000,  
Group 1, Class A. . . . . fulfilled  
EN 50081-2. . . . . fulfilled  
NAMUR recommendation Ne21 Status Aug.1998 fulfilled

### SAFETY REQUIREMENTS

#### CE Label

Electromagnetic compatibility . . . . . 2004/108/EC fulfilled  
Explosion protection acc. to ATEX . . . 94/9/EC

#### Safety

According to EN 61010-1  
(resp. IEC 1010-1) . . . . . safety class III  
Internal fuses . . . . . none (or not replaceable by customer)  
External fuses . . . . . Limitation of power supplies for fire protection have to be observed due to EN 61010-1, appendix F (resp. IEC 1010-1)

### 244LD LevelStar versions ...

... for Left Hand (LH) or  
Right Hand (RH) mounting

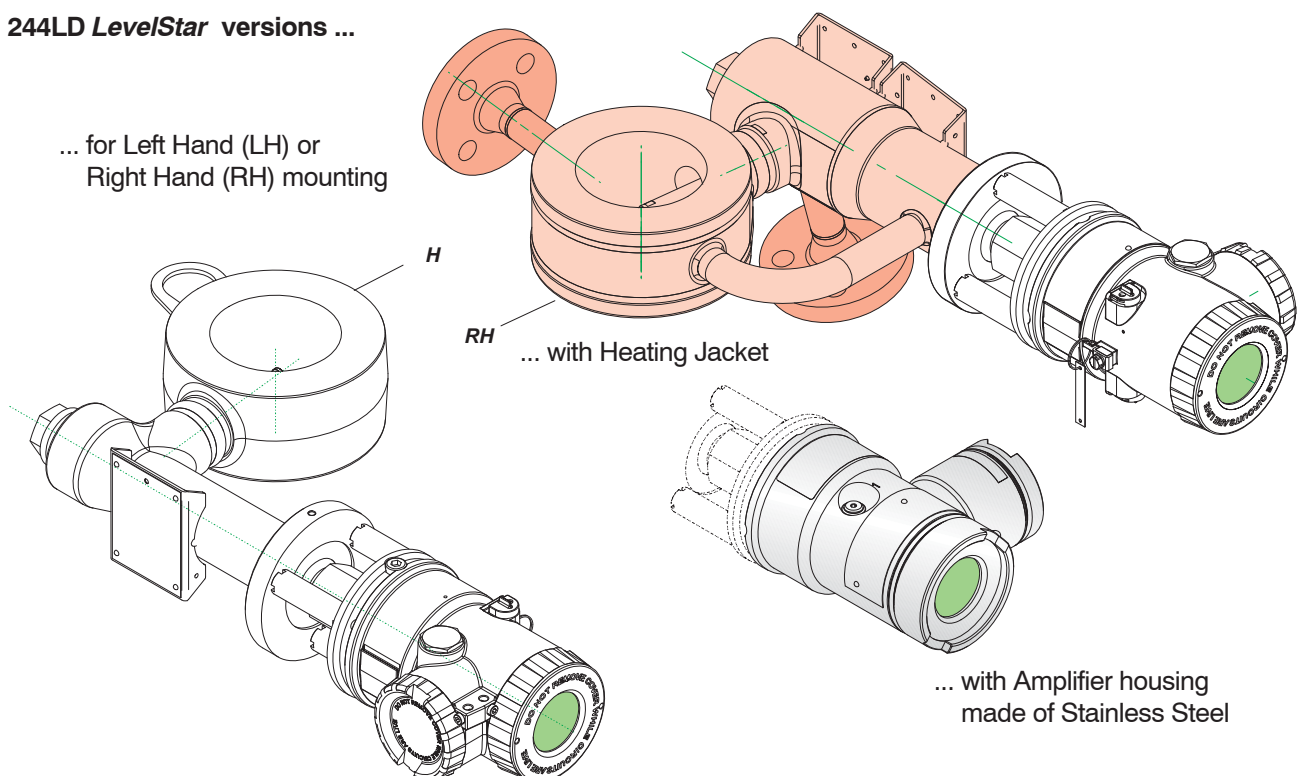

**Electrical classification ATEX** <sup>2) 3)</sup>**intrinsic safe:**

AID 421	II 1/2 G EEx d ib/ia IIC/IIB T4/T6	PTB 04 ATEX 2011X	Zone 0
AID 421	II 2 G EEx d ib/ia IIC/IIB T4/T6	PTB 04 ATEX 2011X	Zone 1

**explosion-proof:**

AD 432	II 1/2 G Ex da/db IIB/IIC T4/T6	PTB 02 ATEX 1025 X	Zone 0
AD 432	II 2 G Ex da/db IIB/IIC T4/T6	PTB 02 ATEX 1025 X	Zone 1

**Zone 2:**

Manufacturer's Declaration

**Further certificates** see also our website:

<http://www.foxboro-eckardt.com>

- FM
- CSA
- NEPSI
- Russia
- Kasachstan
- Approvals for use on sea ships

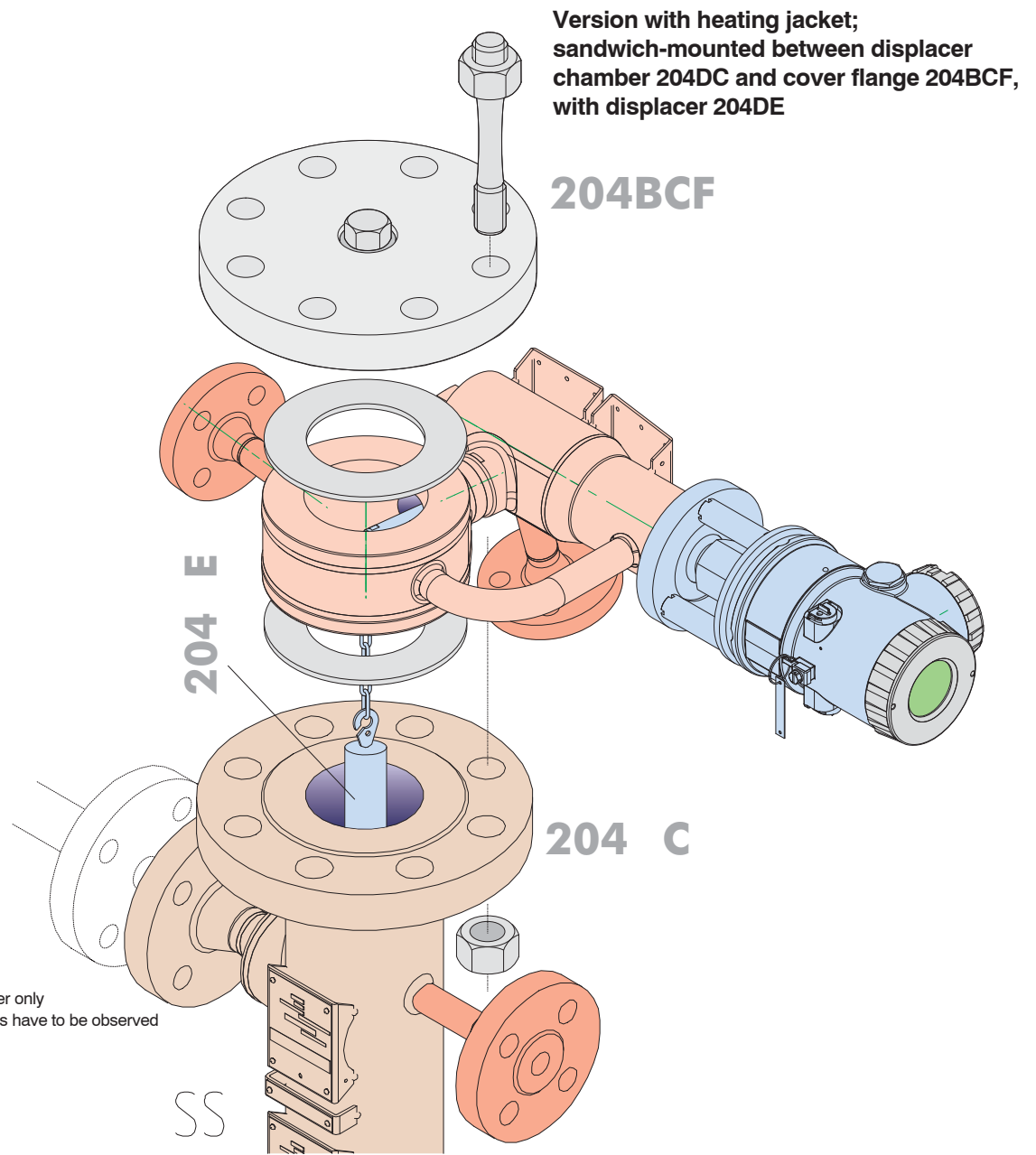

2) With appropriate order only

3) National requirements have to be observed

### Comparison of Material

Code	Wnr	DIN	Remarks	equivalent to
St 35.8 III	1.0305 1.0345	EN 10 216-2		ASTM A 106 Gr.8
C 22.8	1.0460	EN 10 273	VdTÜV - Wbl. 350/3	ASTM A 105
X6 CrNiMoTi 17 12 2	1.4571	17 440		~ ASTM Typ 316Ti
X2 CrNiMo 17 13 2	1.4404			ASTM Typ 316L
X2 CrNiMo 18 14 3	1.4435			
X5 CrNiMo 17 13 3	1.4436			
NiMo 16 Cr 15 W	2.4819	17 744	equ. to Hastelloy C276 VdTÜV - Wbl. 400	UNS N 12 276
NiCr 15 Fe	2.4816	17 742	Inconel 600 VdTÜV - Wbl. 305	UNS N 06600
NiCr 22 Mo 9 Nb	2.4856	17 744	Inconel 625 VdTÜV 499	UNS N 06625
NiCr 21 Mo	2.4858	17 744	Inconel 825 VdTÜV 432	UNS N 08825
X 2 CrNiMo 22 5 3	1.4462	EN 10222-5	Duplex	UNS 31803
GD - AlSi 12	3.2582.05	17 007	Al - Diecasting	

### Service Limits of wafer body PN 250 made of (material)

Max. operating pressure in bar at temperature in °C

#### 1.0460

°C	-10 to 120	200	250	300	350		
bar	250	200	175	150	140	DIN	
bar	231	219	206	180	145	ANSI	

#### 1.4404 / 1.4435 / 1.4571

°C	-196 to -10	-10 ... +50	100	200	300	400	500	
bar	250	250	230	200	177	162	148	DIN
bar	248	248	211	178	158	145	138	ANSI

#### 1.4462

°C	-40 to 50	100	150	200	250	280		
bar	250	225	209	194	184	178	DIN	
bar	260	234	218	201	191	185	ANSI	

#### Inconel 625

°C	-196 to 50	100	200	300	400	450		
bar	250	230	210	197	184	177	DIN	
bar	255	234	214	201	187	181	ANSI	

#### Inconel 825

°C	-10 to 50	100	200	300	400			
bar	250	216	187	176	164		DIN	
bar	260	224	195	183	171		ANSI	

#### Hastelloy C (2.4610 / 2.4819 / 2.4602)

°C	-196 to -10	50	100	200	300	400		
bar	250	250	233	209	200	184	DIN	
bar	260	260	243	217	209	192	ANSI	

### Table of Weights

Transmitter	Weight [kg]					
	DIN PN		ANSI Class			
	16 ... 160	250	150	300 / 600	900	1500
DN 80 / 3 inch	12.5	12.5		12.5		16
DN 100 / 4 inch	13.5	13.5		13.5		18.5



**MODEL CODES 244LD LevelStar** (continued)

ANSI Class 150, Form SG/ST . . . . .	(b)	GT						
ANSI Class 300 to 1500, Form SG/ST . . . . .	(b)	ST						
ANSI Class 150, Form SG/SG . . . . .	(b)	GG						
ANSI Class 300 to 1500, Form SG/SG . . . . .	(b)	SG						
<b>Wafer Body Mounting Direction: (Amplifier to body)</b>								
Right Hand mounted . . . . .								R
Right Hand mounted with heating jacket -								
- connecting flanges B1 / DN15, PN40 (DIN EN 1092-1) . . . . .	(m)(o)(z)							A
- connecting flanges B1 / DN25, PN40 (DIN EN 1092-1) . . . . .	(m)(o)(z)							B
- connecting flanges B2 / DN15, PN40 (DIN EN 1092-1) . . . . .	(m)(o)(z)							C
- connecting flanges B2 / DN25, PN40 (DIN EN 1092-1) . . . . .	(m)(o)(z)							D
- connecting flanges RF/SF, 1/2 inch, Class 300 . . . . .	(m)(o)(z)							E
- connecting flanges RF/SF, 1 inch, Class 300 . . . . .	(m)(o)(z)							F
- connecting flanges RJF, 1/2 inch, Class 300 . . . . .	(m)(o)(z)							G
- connecting flanges RJF, 1 inch, Class 300 . . . . .	(m)(o)(z)							H
Left Hand mounted . . . . .								L
Left Hand mounted with heating jacket -								
- connecting flanges B1 / DN15, PN40 (DIN EN 1092-1) . . . . .	(m)(o)(z)							M
- connecting flanges B1 / DN25, PN40 (DIN EN 1092-1) . . . . .	(m)(o)(z)							N
- connecting flanges B2 / DN15, PN40 (DIN EN 1092-1) . . . . .	(m)(o)(z)							O
- connecting flanges B2 / DN25, PN40 (DIN EN 1092-1) . . . . .	(m)(o)(z)							P
- connecting flanges RF/SF, 1/2 inch, Class 300 . . . . .	(m)(o)(z)							S
- connecting flanges RF/SF, 1 inch, Class 300 . . . . .	(m)(o)(z)							T
- connecting flanges RJF, 1/2 inch, Class 300 . . . . .	(m)(o)(z)							U
- connecting flanges RJF, 1 inch, Class 300 . . . . .	(m)(o)(z)							V
<b>Version:</b>								
Base VERSION - TRANSSTAR - (244LD) . . . . .	(ae)							B
Base VERSION - LEVELSTAR - (244LD) . . . . .	(f)(v)							N
Base (B) TRANSSTAR + Displacer (244LD + 204DE) . . . . .	(ae)							S
Base (N) LEVELSTAR + Displacer (244LD + 204DE) . . . . .	(f)(v)							T
Base (B) TRANSSTAR + Displacer + Displacer Camber + Flange combination + Flange (244LD + 204DE + 204DC + 204FK + 204BCF) . . . . .	(h)(ae)							C
Base (N) LEVELSTAR + Displacer + Displacer Camber + Flange combination + Flange (244LD + 204DE + 204DC + 204FK + 204BCF) . . . . .	(f)(v)(h)							D
<b>Cable Entry:</b>								
M20x1.5 without cable gland . . . . .								M
1/2-14 NPT without cable gland . . . . .								N
<b>Communication:</b>								
HART . . . . .								H
FOUNDATION Fieldbus H1 . . . . .	(aa)							B
<b>Electrical Classification:</b>								
ATEX intrinsic safe Zone 0, IIC T4 (HART) . . . . .	(d)							0C4
ATEX Intrinsic safe Zone 0, IIC T6 (HART or FOUNDATION Fieldbus) . . . . .	(d)							0C6
ATEX intrinsic safe Zone 1, IIC T4 (HART) . . . . .								1C4
ATEX intrinsic safe Zone 1, IIC T6 (HART or FOUNDATION Fieldbus) . . . . .								1C6
ATEX intrinsic safe Zone 2, IIC T4 (HART) . . . . .								2C4
ATEX intrinsic safe Zone 2, IIC T6 (FOUNDATION Fieldbus) Zone 2, IIC T6 (HART) VERSION N, T, D . . . . .	(c)							2C6
ATEX explosionproof Zone 0, IIC T6 . . . . .	(d)							D0C
ATEX explosionproof Zone 1, IIC T6 . . . . .								D1C
FM Nonincendive (HART) (FOUNDATION Fieldbus) . . . . .	(c)							NFM
FM Explosionproof . . . . .								FDZ
CSA Explosionproof . . . . .								CDZ
FM Intrinsically Safe (HART) (FOUNDATION Fieldbus) . . . . .	(c)							FAA
CSA Intrinsically Safe . . . . .	(c)							CAA
GOST-R Intrinsically Safe, T4 (HART) . . . . .	(u)							GA4
GOST-R Intrinsically Safe, T6 (HART or FOUNDATION Fieldbus) . . . . .	(u)							GA6
GOST-R Explosionproof, T6 . . . . .	(u)							GDZ

(continued on next page)



**MODEL CODES 244LD LevelStar** (continued)

GOST-R Intrinsically Safe Zone 0 - IIC T6 (HART) . . . . .	(x)(z)	GA0
GOST-R Intrinsically Safe Zone 1 - IIC T6 (HART) . . . . .	(x)	GA1
GOST-R Intrinsically Safe Zone 2 - IIC T6 (HART) . . . . .	(x)	GA2
GOST-R explosion proof Zone 0 - IIC T6 . . . . .	(x)(z)	GD0
GOST-R explosion proof Zone 1 - IIC T6 . . . . .	(x)	GD1
NEPSI Intrinsically Safe, T4 (HART) . . . . .		NA4
NEPSI Intrinsically Safe, T6 (HART or FOUNDATION Fieldbus) . . . . .		NA6
NEPSI Explosionproof, Ex d IIC T4-T6. . . . .		NDZ
BRAZIL - Intrinsically Safe, T6 (Hart) . . . . .	(q)(v)	BA6
BRAZIL - Explosionproof, Ex d IIC T4-T6 . . . . .	(v)	BDZ
For General Purpose Areas; not Explosionproof . . . . .		ZZZ
<b>OPTIONS:</b>		
Housing Complete Stainless Steel without external Pushbuttons (not available with Wafer Body Material codes K) . . . . .		-H
External Pushbuttons for Maintenance. . . . .	(y)	-M
Remote Amplifier Mounting Kit (3 m), Mounted . . . . .	(e)(u)	-R
Remote Amplifier Mounting Kit (10 m), Mounted . . . . .	(e)(u)	-B
<b>Tag No. Labeling</b>		
Stainless Steel Label Fixed With Wire . . . . .		-L
Stainless Steel Label Fixed On Amplifier . . . . .	(u)	-F
<b>National Certificates</b>		
TA-Luft . . . . .	(u)	-K
ABSA (Canada). . . . .	(u)	-A
Germanischer Lloyd . . . . .	(q)(u)	-G
<b>Certificates</b>		
EN 10204-2.1, Certificate Of Compliance. . . . .		-1
EN 10204-2.2, Specific Test Report (Calibration) . . . . .		-2
EN 10204-3.1, Inspection Certificate Of Process Wetted Material. . . . .		-3
PED 97/23/EC additional unit verification, acc. to module F/G (Not available w. Wafer Body Mat. codes N and I) (ae) . . . . .		-4
Comply With NACE Standard MR-0175 (available with Torque Tube Material I, M or C) . (g) . . . . .		-6
SIL 2 Certificate . . . . .	(q)	-Q
<b>Material Test</b>		
X-Ray or Isotope Test For Weldings . . . . .		-7
Dye Penetration Test . . . . .		-8
PMI - Test . . . . .		-5
<b>Subassemblies</b>		
TRANSSTAR-housing with LEVELSTAR-electronic for selected code (244LD-*****-N) . . . . .	(af)	-N
Torque Tube for selected code (244LD-*****-W) . . . . .	(ab)	-W
Amplifier for selected code (244LD-*****-X) . . . . .	(ac)	-X
Complete Sensor for selected code (244LD-*****-Y) . . . . .	(ad)	-Y
Wafer body for selected code (244LD-*****-Z) . . . . .	(p)	-Z
<p>(a) Available with Wafer Body Flange Size 1 or 2 (b) Available with Wafer Body Flange Size 3 or 4                      (c) Pending                      (d) Not available with Wafer Body Pressure Rating &amp; Contact Face codes L1, J1, J2, J3, H1, H2, DD                      (e) Not available with Electrical Classification FDZ, CDZ, 0C6, D0C, D1C, GDZ, NDZ or Optional Features -H                      (f) Only with Communication H (HART) and electrical Classification 0C6, 1C6, D0C, D1C, 2C6                      (g) Restrictions concerning the limit of application for the used materials are to considering (NACE Standard MR-0175/2003, bzw. ISO 15156-3)                      (h) Pending, order separately at this time.                      (i) Available with Wafer Body Flange Size 0 (k) Available with Wafer Body Flange Size 1                      (m) Wafer Body Flange Size code 3 available only with Wafer Body Pressure Rating code R2, S2, J2                      Wafer Body Flange Size code 4 available only with Wafer Body Pressure Rating code R1, S1, J1, GT, GG                      (n) Available with Wafer Body Material codes S, U, T or Torque Tube Material codes S, C                      (o) Available with Wafer Body Material codes S, U, T                      (p) On request (q) Available with HART (r) D at top (s) F at top                      (u) Not applicable with Version N, T, D                      (v) Pending Electrical Classification FDZ, CDZ, GA6, GDZ, NA6, NDZ, BA6, BDZ                      (w) Version N, T, D with external Pushbuttons                      (x) Available with version N, T, D                      (y) Not with Optionals -H and Version B, S or C                      (z) Not with Pressure Rating H1 or H2                      (aa) Levelstar with Electrical Classification D1C, D0C, 1C6, 0C6, 2C6, ZZZ                      (ab) Not with (Optional feature H, R, B, L, F, V, 9, K, A, G, 2, 4, Q, X, Y, or Z)                      (ac) Not with (Optional feature H, R, B, V, 9, K, A, G, 2, 3, 4, 6, Q, 7, 8, 5, W, Y, or Z)                      (ad) Not with (Optional feature H, R, B, L, F, V, 9, K, A, G, 2, Q, 7, 8, 5, W, X, or Z)                      (ae) PED required for Wafer Body Pressure Rating &amp; Contact Face H1, H2                      PED required for Wafer Body Material A, H, J, Q, R, T, C, N                      PED not available for Optional Feature X, Y, W                      (af) Not with (Optional features: M, R, B, V, 9, K, A, G, 2, 3, 4, 6, Q, 7, 8, 5, W, X, Y, or Z)                      (ag) Not with FF communication</p>		

## Displacer 204DE

### Typical Dimensions and Weights for Density Ranges $\Delta\rho$ <sup>1)</sup>

Material	316L (1.4404 / 1.4435) <sup>2)</sup>													PTFE / PTFE with 25 % C				Hastelloy C276				
Code	-S (PN 100)				-T <sup>3)</sup> (PN 40 / 63)				-S (PN 250)				-S (PN 500)				-S (PN 100 / 160)					
Len. L	Density Range $\Delta\rho$																					
	250 ... 1500 kg/m <sup>3</sup>				300 ... 600 kg/m <sup>3</sup>				400 ... 2000 kg/m <sup>3</sup>				200 ... 1500 kg/m <sup>3</sup>				300 ... 1500 kg/m <sup>3</sup>					
	$\varnothing$ mm	Vol. cm <sup>3</sup>	Wei. N	PN bar	$\varnothing$ mm	Vol. cm <sup>3</sup>	Wei. N	PN bar	$\rho_{\min}$ <sup>4)</sup> kg/m <sup>3</sup>	$\varnothing$ mm	Vol. cm <sup>3</sup>	Wei. N	PN bar	$\varnothing$ mm	Vol. cm <sup>3</sup>	Wei. N	PN bar	$\varnothing$ mm	Vol. cm <sup>3</sup>	Wei. N	PN bar	
<b>mm</b>																						
350	60,3	1000	19	100	101,6	2840	38	40	460	42,4	500	18	250	62	1056	23	500	60,3	1000	18	100	
500	48,3	920	17	100	88,9	3100	43	63	580	42,4	710	24	250	51	1021	23	500	48,3	920	19	100	
750	42,4	1060	21	100	76,1	3410	44	63	545	33,7	670	21	250	42	1039	24	500	48,3	1370	27	100	
1000	33,7	890	17	100	60,3	2855	41	63	545	26,9	570	18	250	35	961	21	500	33,7	890	19	100	
1200	33,7	1070	20	100	60,3	3425	48	63	675	26,9	680	22	250	35	1153	25	500	33,7	1070	22	100	
1500	26,9	850	16	100	51	3065	39	63	460	21,3	540	17	250	30	1060	24	500	26,9	850	18	160	
1800	26,9	1020	19	100	42,4	2540	38	63	495	21,3	640	20	250	28	1107	25	500	26,9	1020	21	160	
2000	26,9	1140	21	100	42,4	2825	41	63	565	21,3	710	22	250	25	981	22	500	26,9	1140	23	160	
2500	21,3	890	20	100	38	2840	37	63	425	17,2	580	16	250	22,5	993	23	500	21,3	890	23	160	
3000	21,3	1070	24	100	38	3400	45	63	575	17,2	700	23	250	20	942	22	500	21,3	1070	27	160	
<b>inch</b>																						
14	60,3	1020	20	100	101,6	2885	38	40	455	42,4	510	18	250	62	1074	23	500	60,3	1020	18	100	
32	42,4	1150	23	100	76,1	3700	47	63	595	33,7	730	23	250	42	1126	26	500	33,7	720	16	100	
48	33,7	1090	20	100	60,3	3480	49	63	680	26,9	690	22	250	35	1171	26	500	33,7	1090	23	100	
60	26,9	870	16	100	51	3115	40	63	465	21,3	540	18	250	30	1076	24	500	26,9	870	18	100	
72	26,9	1040	19	100	42,4	2580	38	63	505	21,3	650	21	250	28	1124	26	500	26,9	1040	21	160	
84	26,9	1210	22	100	42,4	3000	44	63	635	21,3	760	23	250	25	1046	24	500	26,9	1210	25	160	
96	21,3	870	20	100	38	2765	37	63	420	17,2	570	16	250	22,5	968	22	500	21,3	870	23	160	
120	21,3	1090	25	100	38	3455	46	63	595	17,2	710	24	250	20	957	22	500	21,3	1090	25	160	

- $\Delta\rho = \rho_1 - \rho_2$   
 $\rho_1$  = density of lower medium  
 $\rho_2$  = density of upper medium
- Using displacer material 1.4571 can cause small deviations in diameter, volume and weight.
- For measurement of interface or density, the max. density of the lower medium is 1350 kg/m<sup>3</sup>.
- Min. density of the lower medium

If a Displacer Chamber is used, the difference between the diameter of the Displacer and the inside diameter of the Displacer Chamber must be at least 10 mm.

Lengths < 350 mm and > 3000 mm, and density ranges < 300 kg/m<sup>3</sup> and > 2000 kg/m<sup>3</sup> on request.

## Accessories

For Displacer Chamber 204DC, Flange combination 204FK and Cover Flange Kit 204BCF see PSS EML0901, 204.. Accessories for Buoyancy Transmitter.

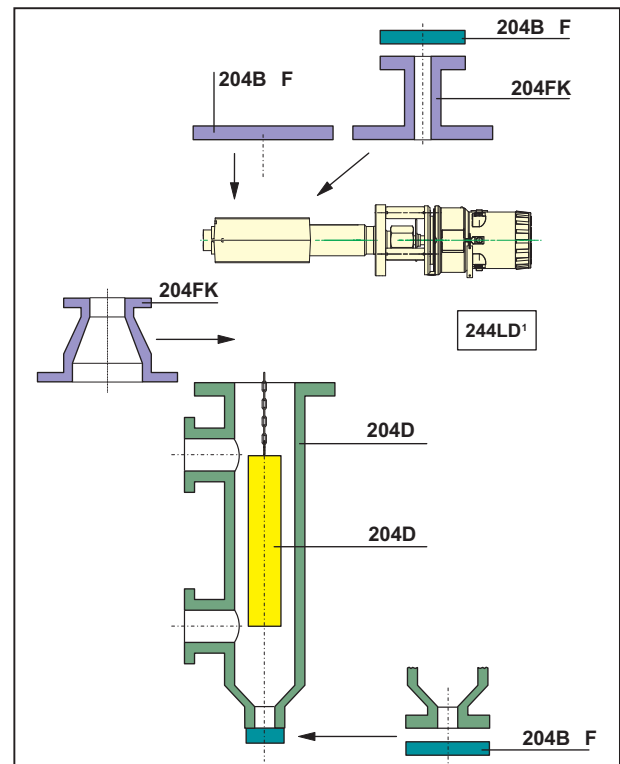

**MODEL CODES 204DE**

<b>Displacer for Buoyancy Transmitters from 2N buoyancy up to 20N 204DE</b>		150715
<b>RANGE OF APPLICATION: (a)</b>		
Liquid Level - Media: Liquid / Gas or Air (Density difference = 250 kg/m <sup>3</sup> to 2000 kg/m <sup>3</sup> ) ( = 9x10 <sup>-3</sup> lbm/in <sup>3</sup> to 72.2x10 <sup>-3</sup> lbm/in <sup>3</sup> ) . . . . .	-S	
Interface Level / Density - Media: Liquid 1 / Liquid 2 (Density difference = 300 kg/m <sup>3</sup> to 600 kg/m <sup>3</sup> ) ( = 10.8x10 <sup>-3</sup> lbm/in <sup>3</sup> to 22.7x10 <sup>-3</sup> lbm/in <sup>3</sup> ) (g)(h) . . . . .	-T	
<b>DISPLACER MATERIAL:</b>		
316L (1.4404 / 1.4435 / 1.4571) . . . . .	S	
321 (1.4541) . . . . .	H	
PTFE (not for applications in Zone 0) . . . . .	P	
PTFE with 25% Carbon . . . . .	O	
Hastelloy C276 . . . . .	C	
Inconel 625 (2.4856) . . . . . (e)	R	
Monel 400 (2.4360) . . . . . (e)	M	
Titan (3.7035) . . . . . (e)	T	
<b>PRESSURE RATING:</b>		
Up to PN 100 / Class 600 . . . . .	D	
Up to PN 160 / Class 900 . . . . .	E	
Up to PN 250 / Class 1500 . . . . .	F	
Up to PN 500 / Class 2500 . . . . .	G	
<b>SUITABLE FOR FLANGE SIZE: (at Top of vessel/chamber)</b>		
DN 50 . . . . .	0	
DN 70 . . . . .	1	
DN 80 . . . . .	2	
DN 100 . . . . .	3	
DN 150 . . . . .	4	
2 inch . . . . .	5	
3 inch . . . . .	6	
4 inch . . . . .	7	
6 inch . . . . .	8	
<b>DISPLACER LENGTH "L": (inches are approx.)</b>		
<b>for Displacer Material codes P and O:</b>		
300 mm (12 in) to 2000 mm (79 in) without partitioning . . . . .	A	
2001 mm (79 in) to 4000 mm (157 in) One partition point . . . . .	B	
4001 mm (157 in) to 6000 mm (236 in) Two partition points . . . . .	C	
6001 mm (236 in) to 8000 mm (315 in) Three partition points . . . . .	D	
8001 mm (315 in) to 10000 mm (394 in) Four partition points . . . . .	E	
10001 mm (394 in) to 12000 mm (472 in) Five partition points . . . . .	F	
<b>for Displacer Material S, H, C, R, M and T:</b>		
300 mm (12 in) to 3000 mm (118 in) without partitioning . . . . .	K	
3001 mm (118 in) to 6000 mm (236 in) One partition point . . . . .	L	
6001 mm (236 in) to 9000 mm (354 in) Two partition points . . . . .	M	
9001 mm (354 in) to 12000 mm (472 in) Three partition points . . . . .	N	
12001 mm (472 in) to 15000 mm (591 in) Four partition points . . . . .	O	
<b>MATERIAL AND LENGTH OF THE SUSPENSION: (Length "b") (d)</b>		
316L / 1.4404 / ... Standard length of Suspension . . . . . (b)	S1	
316L / 1.4404 / ... Customized Suspension Length . . . . . (c)	S2	
321 / 1.4541 Standard length of Suspension . . . . . (b)	H1	
321 / 1.4541 Customized Suspension Length . . . . . (c)	H2	
Hastelloy C276 Standard length of Suspension . . . . . (b)	C1	
Hastelloy C276 Customized Suspension Length . . . . . (c)	C2	
Inconel Standard length of Suspension . . . . . (b)	I1	
Inconel Customized Suspension Length . . . . . (c)	I2	
Monel Standard length of Suspension . . . . . (b)	M1	
Monel Customized Suspension Length . . . . . (c)	M2	
Titan Standard length of Suspension . . . . . (b)	T1	
Titan Customized Suspension Length . . . . . (c)	T2	

(continued on next page)

## MODEL CODES 204DE (continued)

### OPTIONS:

For application in Zone 0 (Additional grounding rope) (not available with Displacer Material: P) . . . . .	-E
Damping Spring (Mat. 1.4310, max. 250 °C (482 °F)) . . . . . (f)	-D
Damping Spring (Mat. HC, max 350 °C (662 °F)) . . . . . (f)	-C
Free of oil and fat. . . . .	-O
Density difference > 300 kg/m <sup>3</sup> . . . . . (a)	-K
Tag No. Labeling Stainless Steel Label Fixed With Wire (Text required). . . . .	-L

### Certificates

EN 10204-2.1 Certificate Of Compliance . . . . .	-1
EN 10204-3.1 Inspection Certificate Of Process Wetted Material (not available with Displacer Material: P and O) . . . . .	-3
PMI - Test (not available with Displacer Material: P and O) . . . . .	-5

- (a) Upper and Lower Medium Density required (at operating temperature)
- (b) Only in connection with Modelcode 204DC
- (c) Exact length required (Contact face of flange to upper end of displacer)
- (d) +/- 8 mm (+/- 0.3 inch)
- (e) On ECEP request
- (f) Required for 244LD with Option -G
- (g) Consult factory if pressure rating is F or G
- (h) Option K required

**Table of versions** for dimensions c, d, g see drawing on next page

Version		Form of Sealings		DN 80 / 3 inch			DN 100 / 4 inch		
				c	d	g	c	d	g
DIN EN	PN								
	16	B1 DIN EN 1092	B2 / C / D / F / E DIN EN 1092	140	82	140	160	102	162
	40								
	63								
	100								
	160	Form L DIN 2696							
250									
ANSI	150	RF / SG / ST ANSI B16.5		140	82	140	160	102	162
	300								
	600								
	900								
	1500								
	150	RJF ANSI B16.5		140	82	140	160	102	174
	300					147			
	600					162			
	900					206			
	1500	LF / LM / LG / LT ANSI B16.5		140	82	140	160	102	174
	300								
	600								
900									
1500									

- RF Raised Face
- RJF Ring Joint Face
- LF Large Female
- LM Large Male
- LG Large Groove
- LT Large Tongue
- SG Small Groove
- ST Small Tongue



**Product Specifications for Intelligent Level Transmitters**

Product Specification: Device:

**LevelWave Radar Transmitters**[PSS EML3010-en](#) LG01 Guided Wave Radar Level Meter[PSS EML3020-en](#) LR01 Free-Space Radar Level Meter**LevelStar Buoyancy Transmitters**[PSS EML0710 G](#) 244LD Intelligent Buoyancy Transmitter for Liquid Level, Interface and Density with Displacer and Torque Tube[PSS EML1710](#) 244LVP Intelligent Buoyancy Transmitter for Liquid Level, Interface and Density with Displacer[PSS EML0901](#) 204xx Accessories for Buoyancy Transmitters

Subject to alterations - reprinting, copying and translation prohibited. Products and publications are normally quoted here without reference to existing patents, registered utility models or trademarks. The lack of any such reference does not justify the assumption that a product or symbol is free.

FOXOBORO ECKARDT GmbH  
Pragstr. 82  
D-70376 Stuttgart  
Germany  
Tel. +49 (0)711 502-0  
Fax +49 (0)711 502-597  
<http://www.foxboro-eckardt.com>

ECKARDT S.A.S.  
20 rue de la Marne  
F-68360 Soultz  
France  
Tel. + 33 (0)3 89 62 15 30  
Fax + 33 (0)3 89 62 14 85

DOKT 556 588 038~1

