

# ASCO™ Solenoid Valves

For Hot Water/Steam Applications

Pilot Operated, 3/8" to 1" Thread

2/2 NC  
Series  
**220**

## Features & Benefits

- Small compact sized valves particularly designed for hot water and steam, compatible with the seal materials used
- For high temperature applications found in laundries, molding, steam atomization, sterilizers, autoclaves,...
- All products are covered by the Pressure Equipment Directive 2014/64/EU and are suitable for group 1 and 2 fluids
- The solenoid valves satisfy all relevant EU Directives and with the provisions of the Directive RoHS 2

## General

Differential pressure

See «SPECIFICATIONS»

Response time

70 - 120 ms

fluids (*)	temperature range (TS)	seal materials (*)
hot water	-20°C to +98°C	PTFE
steam	-20°C to +147°C (class F / class H, DC)	
	-20°C to +173°C (class H, DC)	
	-20°C to +177°C (class H, AC)	

## Materials in contact with fluid

(\*) Ensure that the compatibility of the fluids in contact with the materials is verified

Body	Brass
Shading coil	Copper
Core tube	Stainless steel, AISI 305
Core and plugnut	Stainless steel, AISI 430F
Springs	Stainless steel, AISI 302
Diaphragm assembly	PTFE, stainless steel
Seal	PTFE
Disc	PTFE

## Electrical characteristics

Coil insulation class	F (AC) or H (AC/ DC)
Connector	Spade plug (cable Ø 6-10 mm)
Connector specification	ISO 4400 / EN 175301-803, form A
Electrical safety	IEC 335
Electrical enclosure protection	Moulded IP65 (EN 60529)
Standard voltages	DC (=) : 24V - 48V
(Other voltages and 60 Hz on request)	AC (~) : 24V - 48V - 115V - 230V/50 Hz

operator ambient temperature range (TS) (°C)	class	power ratings				replacement coil	
		inrush ~ (VA)	holding ~ (VA)	hot/cold = (W)	~ 230 V/50 Hz	= 24 V DC	
0 to +52	F	50	25	10.1	-	238613-059	-
	H	-	-	-	15.1/15.6	-	238913-206
0 to +60	H	50	25	10.1	-	238813-059	-

## Options

- Connector with visual indication and peak voltage suppression or with cable length of 2 m

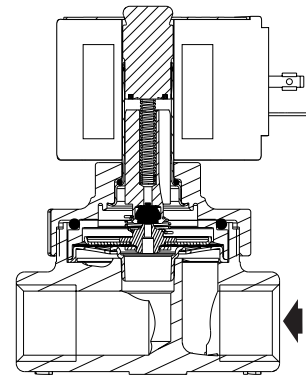
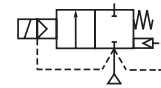

3/8" to 3/4"

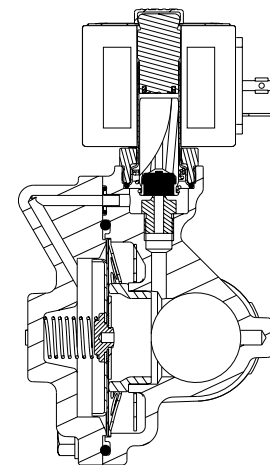

1"

Specifications

														15-DIGIT PRODUCT CODE								
pipe size	orifice size (mm)	flow coefficient Kv (m³/h) (l/min)		operating pressure differential (bar)				max. fluid temp. (°C)	class	power coil (W)		thread type	dimensions / type <sup>(1)</sup>	brass	voltage code							
				max. (PS)						~	=				~	=	24 V/50 Hz	48 V/50 Hz	115 V/50 Hz	230 V/50 Hz	24 V/DC	48 V/DC
				steam (*)		water (*)																
<b>WITHOUT MANUAL OPERATOR</b>																						
NC - Normally closed																						
3/8	12,7	3.8	63.3	0	3	3.4	10	6.9	147	F	10.1	-	G*	01	E220K402S1T00	FL	FR	FT	F8	-	-	
					-	-	-	-	H1	H9												
					9	-	10	-	177	H	10.1	-				G*	01	E220K403S1T00	HL	HR	HT	H8
1/2	12,7	4	66.6	0.3	-	7.5	-	10	173	H	-	15.6	G*	01	E220K405S1T00	FL	FR	FT	F8	-	-	
					-	-	-	-	H1	H9												
					9	-	10	-	177	H	10.1	-				G*	01	E220K406S1T00	HL	HR	HT	H8
3/4	19	7.5	125	0.3	-	7.5	-	10	173	H	-	15.6	G*	01	E220K408S1T00	FL	FR	FT	F8	-	-	
					-	-	-	-	H1	H9												
					9	-	10	-	177	H	10.1	-				G*	01	E220K409S1T00	HL	HR	HT	H8
1	25	10	166.6	0.3	-	7.5	-	10	173	H	-	15.6	G*	01	E220K410S1T00	FL	FR	FT	F8	-	-	
					-	-	-	-	H1	H9												
					3	-	10	-	147	F	10.1	-				G*	02	E220K411S1T00	HL	HR	HT	H8
1	25	10	166.6	0.3	9	-	10	-	177	H	10.1	-	G*	02	E220K411S1T00	HL	HR	HT	H8	-	-	
					-	-	-	-	H1	H9												

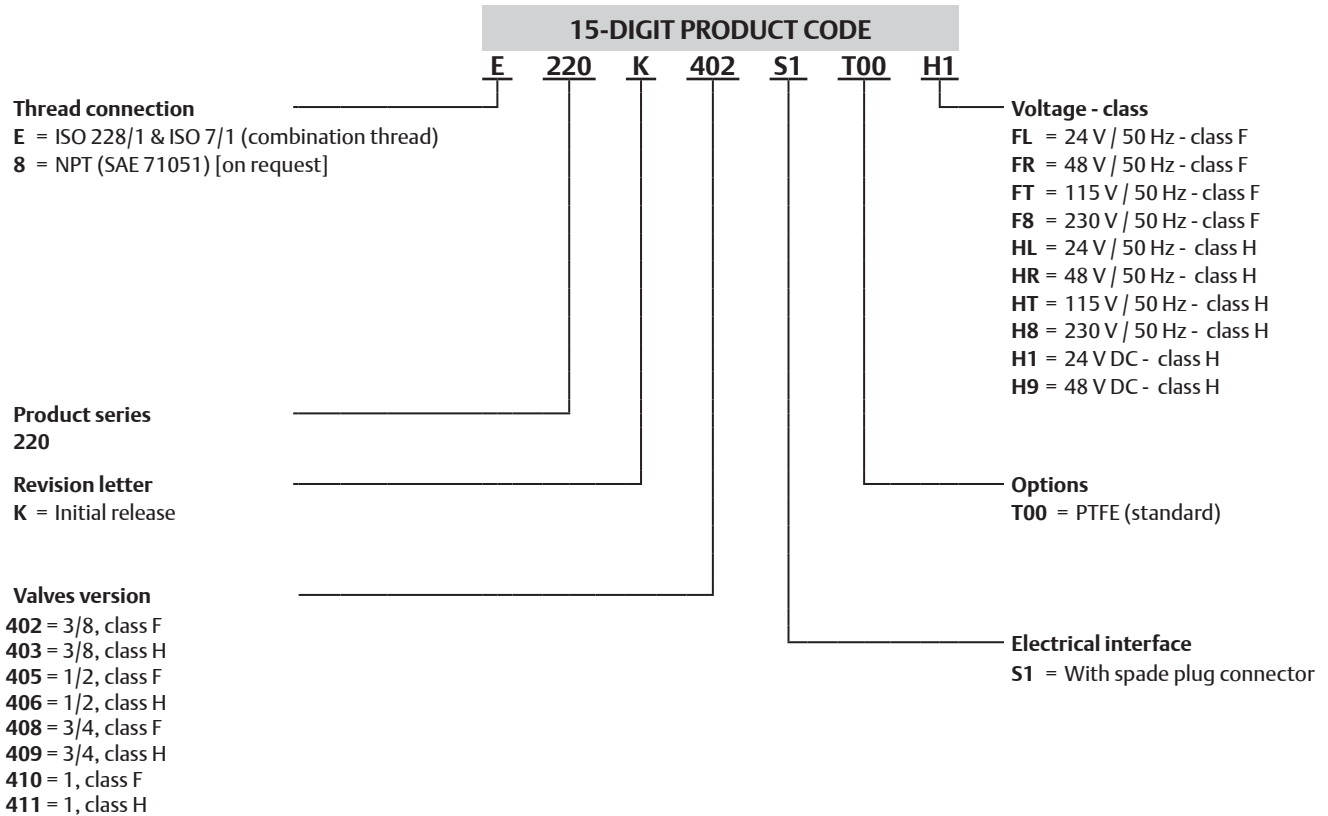

<sup>(1)</sup> For dimensions, see drawing(s) for each construction type on the following page(s).

(\*) Ensure that the compatibility of the fluids in contact with the materials is verified.



## Repair Kits and Service Parts - Spare Parts Kits

1..5 / 11..16 / 21..32 = Supplied in spare part kit.

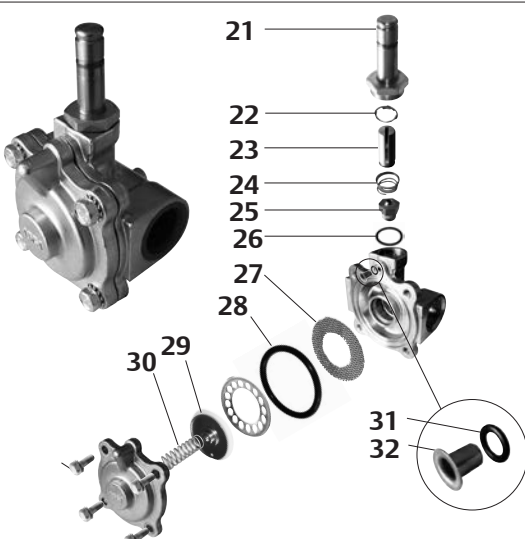
		Spare parts kits no. (*)			
		AC (-)		DC (=)	
			PTFE		PTFE
 <p>1 2 3 4 5</p>	E220K402S1T00FL/FR/FT/F8	M200307	T00	-	-
	E220K402S1T00H1/H9	-	-	M200308	T00
	E220K405S1T00FL/FR/FT/F8	M200307	T00	-	-
	E220K405S1T00H1/H9	-	-	M200308	T00
	E220K408S1T00FL/FR/FT/F8	M200310	T00	-	-
	E220K408S1T00H1/H9	-	-	M200311	T00
 <p>11 12 13 14 15 16</p>	E220K403S1T00FL/FR/FT/F8	M200309	T00	-	-
	E220K403S1T00H1/H9	-	-	M200703	T00
	E220K406S1T00FL/FR/FT/F8	M200309	T00	-	-
	E220K406S1T00H1/H9	-	-	M200704	T00
	E220K409S1T00FL/FR/FT/F8	M200312	T00	-	-
	E220K409S1T00H1/H9	-	-	M200705	T00
 <p>21 22 23 24 25 26 27 28 29 30 31 32</p>	E220K410S1T00FL/FR/FT/F8	M200313	T00	-	-
	E220K411S1T00FL/FR/FT/F8	M200314	T00	-	-

(\*) Ensure that the compatibility of the fluids in contact with the materials is verified.

**Installation**

- The solenoid valves can be mounted in any position without affecting operation. For optimum performance mount solenoid vertical and upright
- Pipe connections (G\*) have standard combination thread according to ISO 228/1 and ISO 7/1
- Installation/maintenance instructions are included with each valve

**Dimensions (mm), Weight (kg)**



**TYPE 01**  
Electrical interface "S1"  
Epoxy moulded  
IEC 335 / ISO 4400  
IP65

E220K402/403/405/406/408/409.....

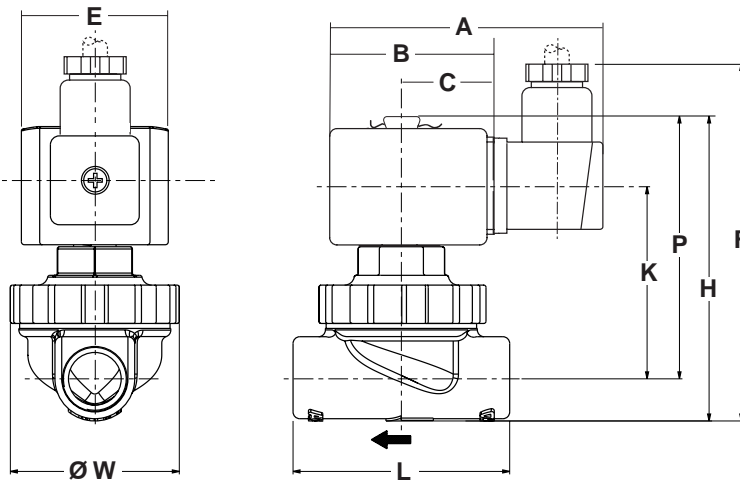

E220K410/411.....

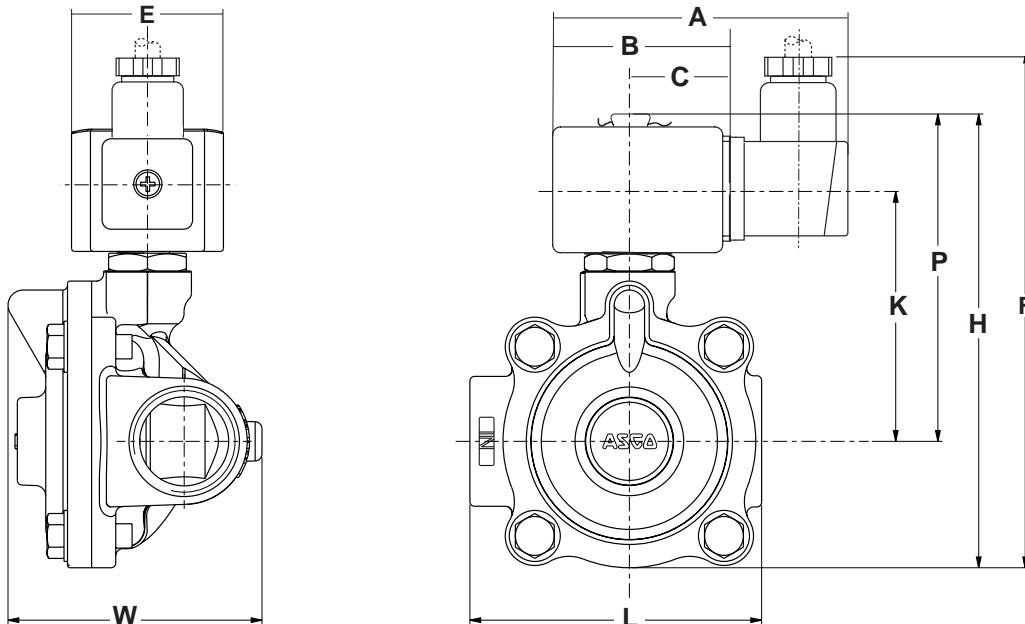

pipe size	A	B	C	E	F	H	K	L	P	W	weight <sup>(1)</sup>
3/8 - 1/2	91	51	30	50	132	104	65	73	90	57	0.875
3/4	95	57	33	50	134	106	64	73	89	72	0.875
1	96	59	34	50	180	148	82	95	106	83	2.013

<sup>(1)</sup> Incl. coil(s) and connector(s).