

Micro Motion™ Series 3000 Transmitters with MVD™ Technology



- **Platform architecture designed for flexibility**
 - Transmitter and/or controller in field-, rack-, or panel-mount design
 - Wide range of I/O channels for maximum functionality
- **Broadest range of application coverage**
 - Advanced density options enable measurement of concentration, petroleum, net volume, water cut, and associated net oil/water flow
 - Provides powerful and easy one-stage or two-stage batch control with ticket printing output
 - Delivers effective security capabilities suitable for custody transfer applications
- **Single operator interface for easy setup, control, and operation**
 - Full configuration capabilities eliminate the need for external tools
 - Large display provides easy-to-read menus and descriptive alarms
 - Enables Smart Meter Verification for quick, complete meter diagnosis without process interruption

MICRO MOTION™



Micro Motion Series 3000 transmitters

Series 3000 transmitters electronics combine transmitter functions and PLC capabilities in one instrument. Series 3000 models feature MVD technology, enabling high-speed digital signal processing (DSP) capabilities and a broad range of specialty applications.

MVD technology makes your meter work smarter

- Front end signal processing gives faster response time and dramatically reduces signal noise
- Provides reduced wiring costs through use of standard 4-wire instrument cable
- On-board signal processing results in the cleanest, most accurate signal delivered, even with tough measurement conditions such as entrained gas

Smart Meter Verification: advanced diagnostics for your entire system

- A comprehensive test that can be run locally or from the control room to provide confidence in your meter functionality and performance
- Verifies that your meter performs as well as the day it was installed, giving you assurance in less than 90 seconds
- A basic version of Smart Meter Verification is included with new enhanced core processors that provides simple pass/fail results, and simple diagnostics that run without interrupting your processes
- A licensed version includes enhanced capabilities, such as viewing previous results and generating comprehensive reports

Mounting and Installation flexibility to fit your exact needs

- Form factors include rugged field mounts with a full suite of hazardous area approvals or DIN rail packages for cost effective control room cabinets
- Local user interfaces provide detailed operator feedback and accessibility
- Connection to new or existing Micro Motion sensors easily achieved through flexible configurations

Control and Application Tailored Software

- 3500 and 3700 transmitters measure and control based on direct input from a Micro Motion Coriolis meter
- 3300 and 3350 models control based on a frequency input from a remote transmitter
- Specialty application software available such as batch control, petroleum measurement, net oil measurement, and custody transfer security

Applications

Application are custom designed programs and software available to offer additional functionality and performance to transmitters. These applications are available through options in the transmitter model code, see the ordering information section for details.

Process monitor / totalizer

Process monitoring and totalizing for multiple variables, including mass flow, volume flow, density, and temperature, reported in the user's choice of unit. Unit options include all common units, plus °API, SCF, beer barrels, etc., and the ability to define a special unit for mass, volume, or gas standard volume.

Smart Meter Verification (SMV)

- Provides a quick, complete assessment of a Coriolis meter, determining whether the meter has been affected by erosion, corrosion, or other influences affecting meter calibration.

- No secondary references are required to perform this operation, and the meter can continue normal process measurement while the test is in progress.
- A basic version of Smart Meter Verification is included with new enhanced core processors that provides simple pass/fail results, and simple diagnostics that run without interrupting your processes.

Discrete batch control

- Configuration of up to six preset batch recipes
- One-stage or two-stage batch control
- End-of-batch warning and batch-overflow alarms
- Automatic overshoot compensation

Weights & Measures custody transfer

Note

If you are using the Weights & Measures application, you cannot use the Net Oil application.

- Physical and software security
- Security-alarm posting
- Mass or volume totalizer that can be configured by the user
- Compliant with MID 2014/32/EU Annex MI-005
- Certified by NTEP and OIML

Concentration measurement

Provides concentration measurement based on either industry-specific or liquid-specific units and relationships. Standard measurement options include:

- Industry-specific:
 - °Brix
 - °Plato
 - °Balling
 - °Baumé at SG60/60
 - Specific gravity
- Liquid-specific:
 - %HFCS
 - Concentration derived from reference density
 - Concentration derived from specific gravity

Additionally, the application can be customized for site-specific concentration measurement (such as %HNO₃, %NaOH).

Petroleum measurement

Adds the following calculations to the standard software:

- Calculates base density (corrected API Gravity) and Ctl (the correction for the effect of temperature on a liquid)
- Calculates gross volume at standard temperature
- Calculates flow-weighted average temperature and flow-weighted average observed gravity (flowing density)

Transient Bubble Remediation (TBR)

- Used with single-component liquid streams that may experience intermittent low levels of gas entrainment, that is, gas carryunder

- Enables accurate measurement of a single fluid during periods of entrained gas by providing a substitute density value based on the immediately preceding process density (standard configuration)
- Tracks total time of aerated flow to assist in diagnosing process issues that may cause aeration

Transient Mist Remediation (TMR)

- Used with gas streams that may experience intermittent low levels of liquid entrainment, i.e., liquid carry-over
- Allows gas measurement to continue during periods of entrained liquid (mist) by providing a substitute flow rate value based on the immediately preceding process flow rate
- Returns to reporting the measured flow rate when the mist interval is over, increased or decreased by a maximum of 10%, until flow totals are appropriately adjusted for the unmeasured flow
- Provides an indication of the amount of time that liquid was present in the stream — identifying process improvements to reduce gas stream contamination

Net Oil (NOC)

Note

If you are using the Net Oil application, you cannot use the Weights & Measures custody transfer application.

- Designed for use with two-phase, three-phase, or compact separators
- Supports up to 48 wells, three well tests per well (well test mode), or continuous measurement of one well
- Measures and reports net oil and net water production
- Real-time water cut data based on process density or read from water cut probe
- Optionally reports gas production
- Enables recalculation of stored NOC data for different reference values

Electrical connections

Connection type	Model 3300/3500 rack-mount	Model 3300/3500 panel-mount	Model 3350/3700 remote field-mount
Input/Output	<ul style="list-style-type: none"> ■ Type D connectors per DIN standard 41612 (IEC 603-2) ■ Solder tails (standard) ■ Wiring terminals (optional); accept wire 24 AWG (0.205 mm²) to 16 AWG (1.31 mm²) 	<ul style="list-style-type: none"> ■ Intrinsically safe version: Two pairs of wiring terminals for transmitter outputs ■ Non-intrinsically safe analog outputs (output option A): Three pairs of wiring terminals for transmitter outputs 	<p>Two color-coded wiring compartments:</p> <ul style="list-style-type: none"> ■ Compartment with intrinsically safe terminals has two .75 in NPT or M20 × 1.5 conduit openings ■ Compartment with non-intrinsically safe terminals has three .75 in NPT or M20 × 1.5 conduit openings ■ Wiring terminals accept wire 22 AWG (0.326 mm²) to 16 AWG (1.31 mm²)
Power	<ul style="list-style-type: none"> ■ Screw terminals are fixed to rack chassis ■ Ground makes first and breaks last 	Screw terminals	
All power supply screw terminals accept wire 22 AWG (0.326 mm ²) to 16 AWG (1.31 mm ²)			

Connection type	Model 3300/3500 rack-mount	Model 3300/3500 panel-mount	Model 3350/3700 remote field-mount
Service port	Two clips for temporary connection to the service port		One pair of terminals supports Modbus/RS-485 signal or service port mode. On device power-up, the user has 10 seconds to connect in service port mode. After 10 seconds, the terminals default to Modbus/RS-485 mode.

Sensor cabling

Specification	Value			
Requirements Applies to Model 3500/3700 only. Sensor cabling not applicable to Models 3300/3350.	With sensor interface code 5 <ul style="list-style-type: none"> Requires standard 4-wire twisted-pair signal cable between the sensor and the transmitter. Micro Motion recommends using Micro Motion 4-wire cable. 			
	With sensor interface code 6 <ul style="list-style-type: none"> Requires standard 4-wire twisted-pair shielded signal cable between the transmitter and the remote core processor. Micro Motion recommends using Micro Motion 4-wire cable. Requires Micro Motion 9-wire signal cable between the remote core processor and the sensor. 			
	Depending on the order, 10 ft (3 m) of 4-wire cable or 10 ft (3 m) of both 4-wire and 9-wire cable are shipped with the order. For longer cable lengths, contact Micro Motion.			
Maximum cable lengths between sensor and transmitter	Cable type	Wire gauge	Maximum length	
	Micro Motion 4-wire	Not applicable	<ul style="list-style-type: none"> 1,000 ft (305 m) without Ex-approval 500 ft (152 m) with IIC rated sensors 1,000 ft (305 m) with IIB rated sensors 	
	Micro Motion 9-wire	Not applicable	60 ft (18 m)	
	User-supplied 4-wire:	VDC 22 AWG (0.326 mm ²)		300 ft (91 m)
		VDC 20 AWG (0.518 mm ²)		500 ft (152 m)
VDC 18 AWG (0.823 mm ²)			1,000 ft (305 m)	
RS-485 22 AWG (0.326 mm ²) or larger			1,000 ft (305 m)	

Input signal detail

Input	Description
One 2-wire frequency/pulse input	<ul style="list-style-type: none"> ■ Not intrinsically safe ■ Frequency range: 0–15 khz ■ Minimum pulse width: 25 μ-sec ■ Power: Sourcing or sinking ■ Voltage: 0–0.8 VDC low state; 3–30 VDC high state ■ Current: Nominal 5 mA pull-up
Two discrete momentary inputs	<ul style="list-style-type: none"> ■ Not intrinsically safe ■ Pulse width: 0.15sec minimum ■ Voltage: 0–0.8 VDC low state; 3–30 VDC high state ■ Dry contacts
One 4-wire Coriolis sensor signal input with ground	Intrinsically safe

Output signal detail

Output	Description
Two active 4–20 mA Outputs	<ul style="list-style-type: none"> ■ Isolated to \pm50VDC from all other outputs and earth ground ■ Maximum load limit: 100 ohms ■ Output is linear with process from 3.8 to 20.5 mA per NAMUR NE43 (February 2003)
Three Discrete Outputs	<ul style="list-style-type: none"> ■ Not intrinsically safe ■ Configurable for the application ■ Polarity: Active high or active low, software selectable ■ Power: Internal pull-up to 24V ■ Current: Sourcing at 5.6 mA when $V_{out} = VDC$; Sinking up to 500 mA at 30 VDC maximum

Output	Description
One 2-wire frequency/pulse output	<ul style="list-style-type: none"> ■ Not intrinsically safe ■ Scalable to 10,000Hz ■ Output is linear with flow rate to 2,500 Hz ■ Pulse width: 50% duty cycle above the crossover frequency⁽¹⁾; configurable between 0.543 ms and 277 ms ■ Polarity: Active high or active low, software selectable ■ Power: Active or passive, software selectable ■ Voltage: 24 VDC nominal, active; 30 VDC applied maximum, passive ■ Current: Sourcing at 10 mA at 3 VDC, active; Sinking at 500mA, active or passive

(1) The crossover frequency depends on the configured value of the pulse width. At the minimum pulse width value of 0.543 ms, the crossover frequency is 922 Hz. At the maximum pulse width value of 277 ms, the crossover frequency is 1.8 Hz..

Fault actions	Description
When a fault is detected, outputs go to configured states. User can select upscale, downscale, internal zero, or none. Milliamp outputs conform to NAMUR NE43 (February 2003).	
Upscale	<ul style="list-style-type: none"> ■ Milliamp: 21 to 24 mA, user configurable ■ Frequency: 15,000 Hz
Downscale	<ul style="list-style-type: none"> ■ Milliamp: 1 to 3.6 mA, user configurable ■ Frequency: 0 Hz
Internal zero	Drives the mA and frequency
None	Ignores fault conditions

Digital communications

Output type	Outputs and descriptions
RS-485	<p>One pair of terminals supports Service Port (SP) mode or RS-485 mode. In RS-485 mode the port can be used for Modbus/HART communication or as a printer port.</p> <p>On device power-up, the user has 10 seconds to connect in SP mode. After 10 seconds, the terminals switch to RS-485 mode.</p> <p>Service port mode</p> <ul style="list-style-type: none"> ■ Protocol: Modbus RTU ■ Data rate: 38,400 baud ■ Parity: no parity ■ Stop bit: one stop bit ■ Address: 111

Output type	Outputs and descriptions
	<p>RS-485 for Modbus/HART protocols</p> <p>The transmitter can communicate via Modbus RTU, Modbus ASCII, or HART⁽¹⁾ protocols. The communication parameters are configurable with ProLink III software, Modbus, or the display. The shipped default parameters are:</p> <ul style="list-style-type: none"> ■ Data rate: 9600 baud ■ Parity: odd ■ Stop bit: one stop bit
	<p>RS-485 for printer port</p> <p>When the RS-485 port is configured as a printer port, it cannot be used for any other function.</p> <ul style="list-style-type: none"> ■ Requires external RS-232 adapter (not included) ■ With Epson TM-U295 ticket printer, detects and reports “paper out” conditions ■ Is approved for use in custody transfer applications
HART/Bell 202⁽¹⁾	<p>The HART Bell 202 signal is superimposed on the primary mA output, and is available for host system interface or for polling external measurement devices. The HART Bell 202 communication parameters are:</p> <ul style="list-style-type: none"> ■ Frequency: 1.2 and 2.2 KHz ■ Amplitude: 0.8 mA peak-to-peak ■ Data rate: 1200 baud ■ Resistance: Loop requires 250 to 600 ohms resistance

(1) HART protocol supports configuration of basic transmitter functionality, configuration of the petroleum measurement application, and reading/writing batch setpoints and totals. HART protocol does not support configuration of the batch, concentration measurement, or NOC applications. Both Modbus and the display provide configuration and control of all transmitter functionality.

Power supply

Type	Description
AC power supply	<ul style="list-style-type: none"> ■ 85 to 265 VAC ■ 8 watts typical, 15 watts maximum ■ IEC 60127-3 fuse, 0.63 A time-delay ■ Complies with low voltage directive 2006/95/EC per EN 61010-1 (IEC 61010-1) with amendment 2; Installation (Overvoltage) Category II, Pollution Degree 2
DC power supply	<ul style="list-style-type: none"> ■ 18 to 30 VDC ■ 8 watts typical, 11 watts maximum ■ IEC 60127-3 fuse, 1.6 A time-delay ■ The user-supplied power conductors must be appropriately sized to provide 18 VDC minimum at the power terminals at a load current of 0.7 A.

Environmental limits

Table 1: Ambient temperature limits

Type	Temperature limits
Operating	-4 °F (-20.0 °C) to 140 °F (60.0 °C)
Storage	-40 °F (-40.0 °C) to 158 °F (70.0 °C)

Table 2: Humidity and vibration limits

Type	Values
Humidity limits	5 to 95% relative humidity, non-condensing at 140 °F (60.0 °C)
Vibration limits	Meets IEC 60068-2-6, endurance sweep, 5 to 2000 Hz up to 1.0 g

Table 3: Housing rating

Model	Values
Model 3350/3700	NEMA 4X (CSA) and IP66/IP67 (ATEX/IECEX)
Model 3300/3500	At least IP20

Environmental effects

EMI effects

- Complies with EMC directive 2014/30/EU per EN 61326 Industrial
- Complies with NAMUR NE-21 (May 2012)
- Complies with NAMUR NE-21 (22.08.2007)

Ambient temperature effect

On analog outputs: $\pm 0.005\%$ of span per °C change from temperature at which the outputs were trimmed

Model 3100 accessory specifications

Relays module:

- Three relays
- Solid state, SPST
- Rated at 24–250 VAC, 40 mA to 5A; or 0–70 VDC, 5A
- Energized by Discrete Outputs
- NEMA 4X (IP65) enclosure (optional)



Hazardous area classifications

Model 3300



UL and CSA

Approval Type	Approval	
UL and CSA		Class I, Div. 2, Groups A, B, C, and D when installed in a suitable enclosure



Model 3350

Approval Type	Approval	
UL and CSA		Class I, Div. 2, Groups A, B, C, and D (standard housing)
ATEX		ATEX Zone 1 I 2G Ex de [ib] IIB/IIC T4 Gb
		IECEX Zone 1
IECEX		IECEX Zone 1 Ex de [ib] IIB/IIC T4 Gb

Model 3500

Approval Type	Approval	
UL and CSA		Class I, Div. 2, Groups A, B, C, and D when installed in a suitable enclosure Provides non-incendive sensor outputs for use in Class I, Div. 2, Groups A, B, C, and D, or intrinsically safe sensor outputs for use in Class I, Div. 1, Groups C and D; Class II, Div. 1, Groups E, F, and G
ATEX		Safe area only: II (2) G [Ex ib] IIB/IIC Can be connected to a sensor in Zone 1 area if sensor is marked as Ex ib IIB/IIC.

Model 3700

Approval Type	Approval	
UL and CSA		Class I, Div. 2, Groups A, B, C, and D Provides non-incendive sensor outputs for use in Class I, Div. 2, Groups A, B, C, and D, or intrinsically safe sensor outputs for use in Class I, Div. 1, Groups C and D; Class II, Div. 1, Groups E, F, and G
ATEX		ATEX Zone 1: II 2G Ex de [ib] IIB/IIC T4 Gb
IECEX		IECEX Zone 1 Ex de [ib] IIB/IIC T4 Gb

Model 3100 Accessory (relays model)

UL and CSA

Approval Type	Approval	
UL and CSA		Class I, Div. 2, Groups A, B, C, and D

Marine approval classifications

Marine approval	Country
Lloyds Register ENV1, ENV2, ENV3, ENV5	United Kingdom
Det Norske Veritas- Germanischer Lloyd	Norway-Germany
Bureau Veritas	France
American Bureau of Shipping	USA
Nippon Kaiji Kyokai	Japan

Physical specifications

Model 3300/3500 rack or panel mount

Specification	Value
Housing	<p>Rack</p> <ul style="list-style-type: none"> 19 in (483 mm) rack-mount housing meets DIN standard 41494 and IEC 297-3 Front panel is rated IP40. Front panel is aluminum with laminate overlay <p>Panel</p> <ul style="list-style-type: none"> Front panel with bezel is rated NEMA 4X (IP65) Front panel is aluminum with laminate overlay
Weight ⁽¹⁾	<ul style="list-style-type: none"> Maximum 3.5 lb (1.59 kg), excluding prepared cables
Terminal compartments	<ul style="list-style-type: none"> Output terminals are physically separated from the power and service-port terminals.
Standard interface/display	<p>Display</p> <ul style="list-style-type: none"> Backlit LCD, 128 x 128 pixel, bit map Adjustable contrast Non-glare, chemical-resistant acrylic lens <p>Interface (keypad membrane switch)</p> <ul style="list-style-type: none"> Large push buttons with tactile feedback Software-defined function keys Chemical-resistant polyester

(1) For transmitters integrally mounted to a sensor, you may need to add the weight of the transmitter to the sensor. Refer to the sensor product data sheet.

Model 3350 and 3700 remote field mount

Specification	Value
Housing	<p>Compartment with threaded cover contains electronics.</p> <p>Terminal compartment contains:</p> <ul style="list-style-type: none"> Non-intrinsically safe compartment with input/output and power supply terminals Intrinsically safe compartment with interface/display, sensor terminals (Model 3700 only), and optional input and output terminals
Weight ⁽¹⁾	<ul style="list-style-type: none"> 19 lb (8.6 kg)
Terminal compartments	<p>Compartment with threaded cover contains electronics.</p> <p>Terminal compartment contains:</p> <ul style="list-style-type: none"> Non-intrinsically safe compartment with input/output and power supply terminals Intrinsically safe compartment with interface/display, sensor terminals (Model 3700 only), and optional input and output terminals

Specification	Value
Mounting	<ul style="list-style-type: none"> Mounting bracket and interface/display rotate to allow mounting in four different orientations
Standard interface/display	<p>Display</p> <ul style="list-style-type: none"> Backlit LCD, 128 x 128 pixel, bit map Adjustable contrast Non-glare, tempered glass lens Suitable for hazardous area installation <p>Interface (keypad membrane switch)</p> <ul style="list-style-type: none"> Large push buttons with tactile feedback Software-defined function keys Chemical-resistant polyester

(1) For transmitters integrally mounted to a sensor, you may need to add the weight of the transmitter to the sensor. Refer to the sensor product data sheet.

Rack-mount Model 3300/3500 dimensions

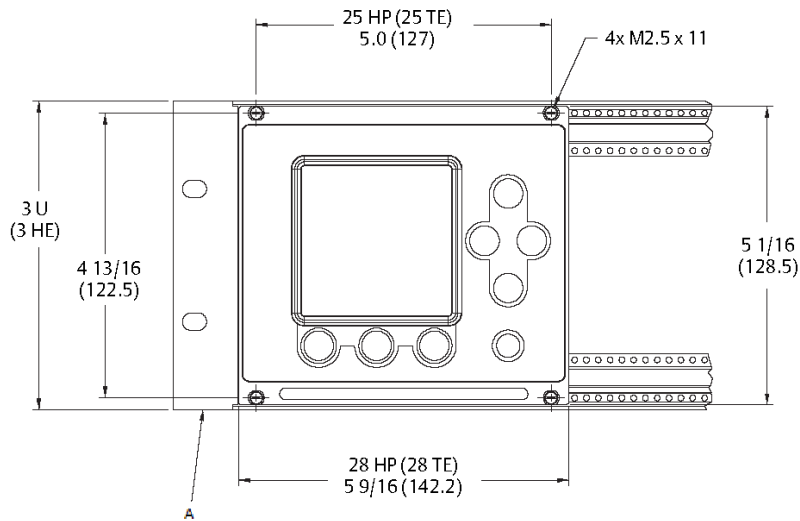

A. 19 in (483 mm) sub-rack conforms to EN 60297-3-101 and IEC 60297-3. Not included as part of Model 3300/3500

Note

- Dimensions are in inches (mm).
- 1 U = 1 HE = 1.750 in (44.45 mm)
- 1 HP = 1 TE = 0.200 in (5.08 mm)

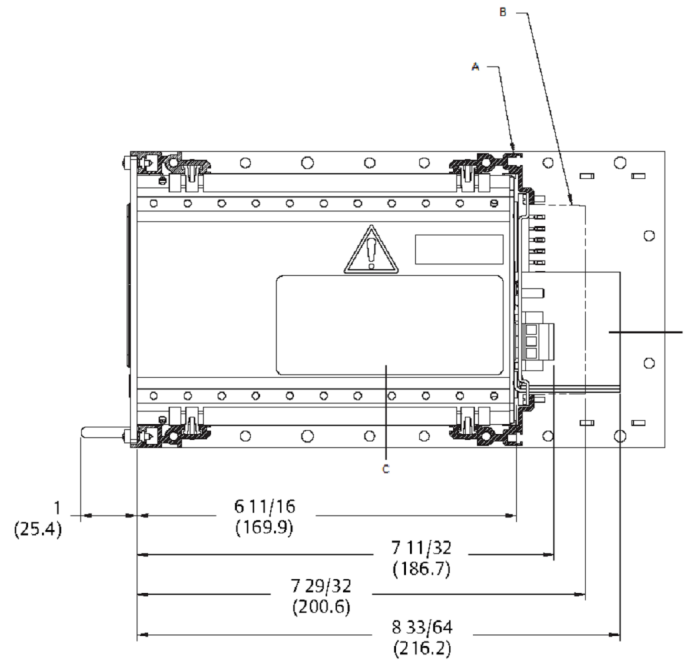

Note

Dimensions are in inches (mm).

- A. Rear rail for mounting connectors that conform to EN 60603-2 and IEC 60603-2. Not included as part of Model 3300/3500
- B. Wiring terminal connector (optional)
- C. Approvals tag
- D. Intrinsic safety shield (Model 3500 only)

Panel mount Model 3300/3500 with screw-type connectors

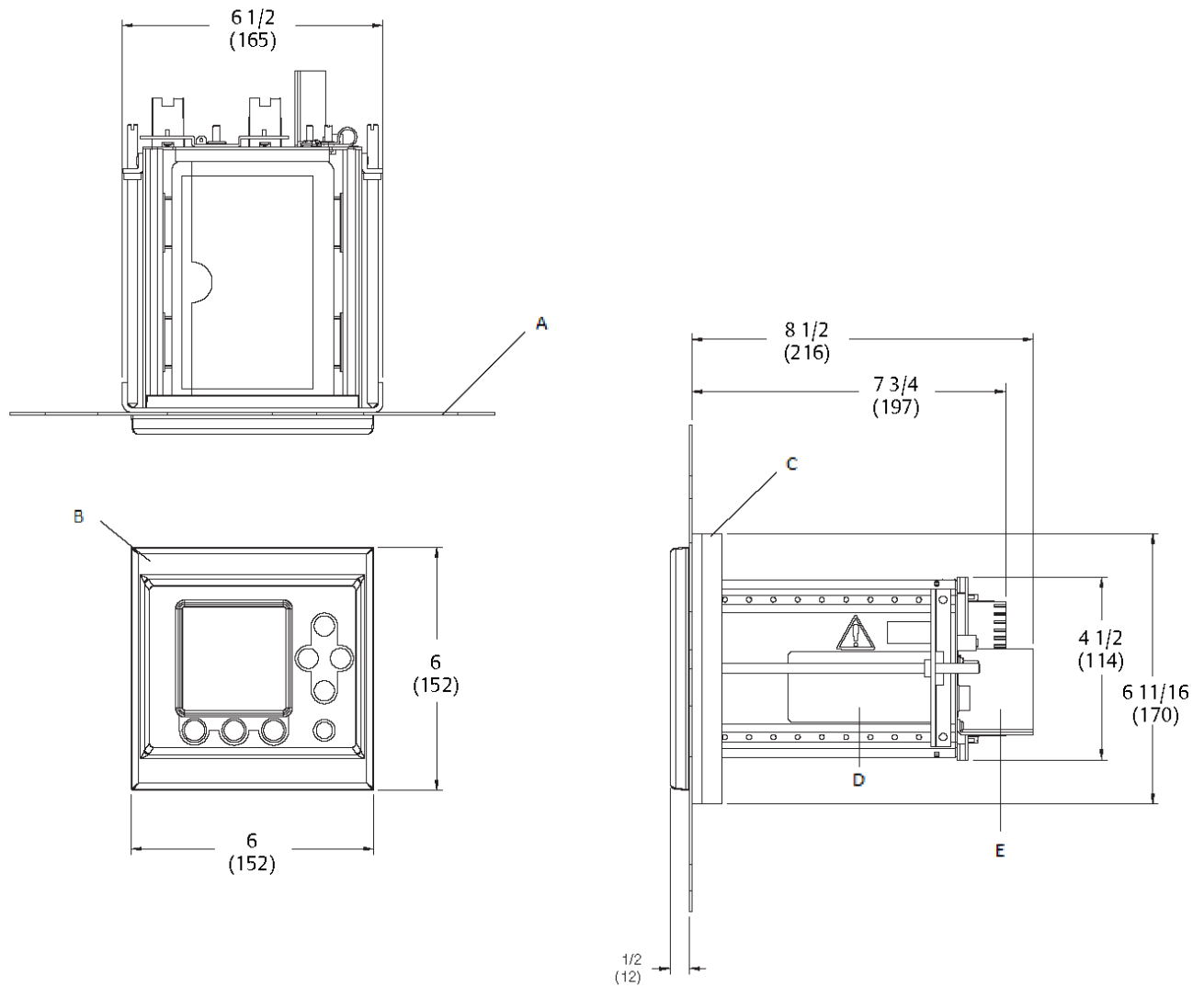

- A. Panel
- B. Bezel
- C. Frame
- D. Approvals tag
- E. Intrinsic safety barrier (Model 3500 only)

Note

- Dimensions are in inches (mm).

Panel-mount Model 3300/3500 with optional I/O cable

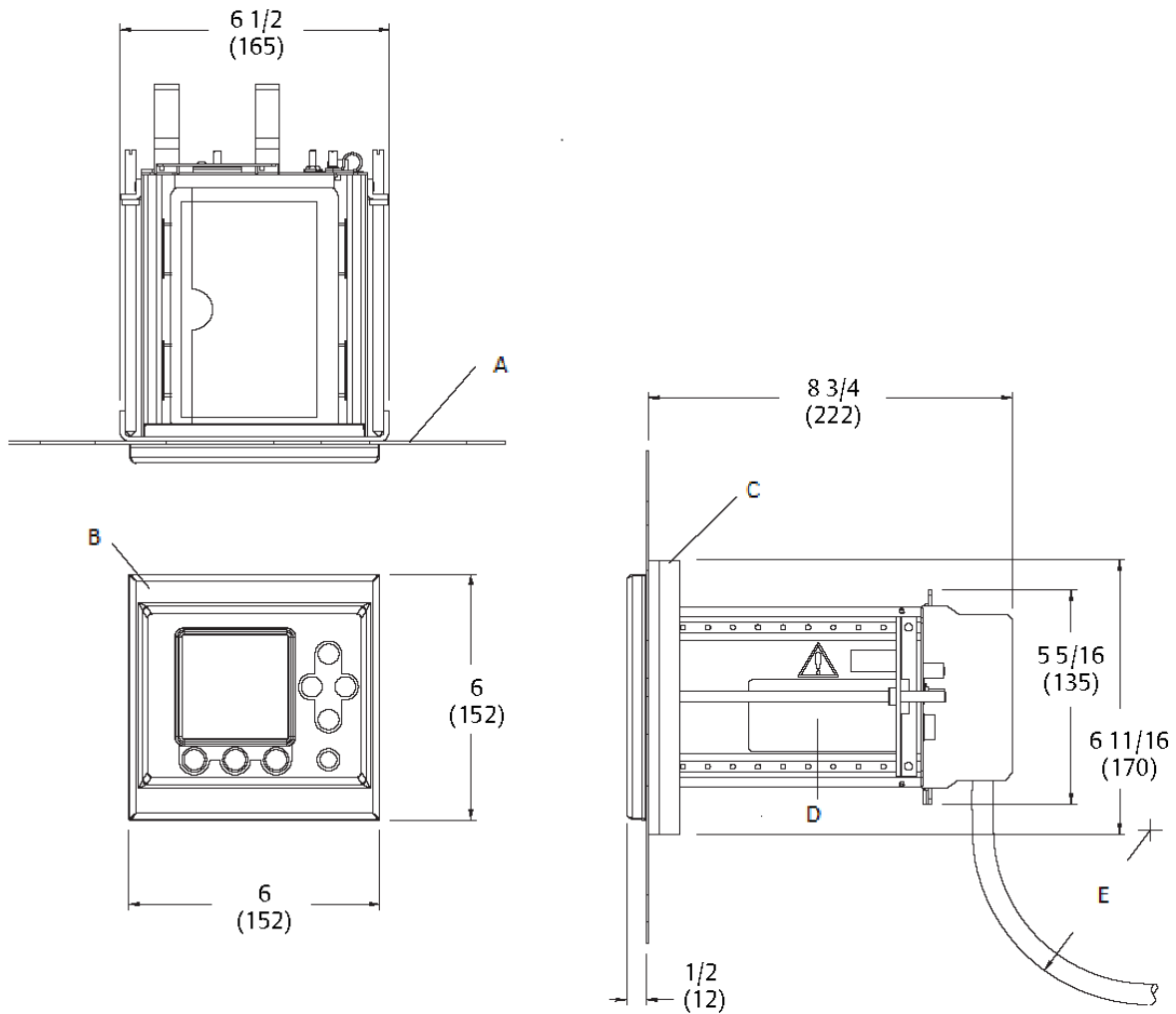

- A. Panel
- B. Bezel
- C. Frame
- D. Approvals tag
- E. Minimum 4.25 in (107.9 mm) bend radius

Note

- Dimensions are in inches (mm).

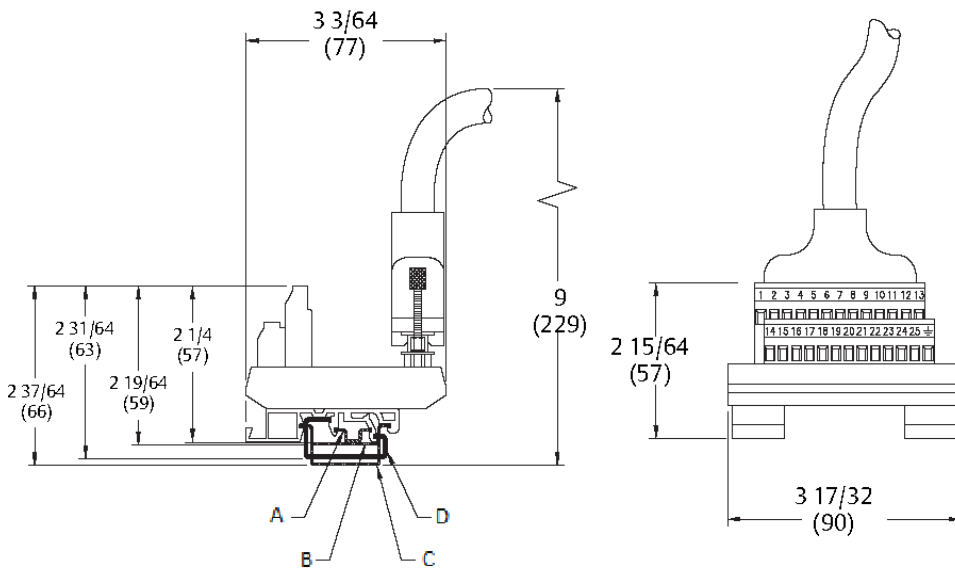

- A. DIN rail type TS 15
- B. DIN rail type TS 35 x 7.5
- C. DIN rail type TS 35 x 15
- D. DIN rail type TS 32

Ordering information

Model 3300

Base model

Model	Product description
3300	MicroMotion Coriolis Discrete Controller MVD 3300 ; remote rack/panel-mount

Mounting

Code	Mounting options for Model 3300
R	DIN rack
P	Panel-mount

Power

Code	Power options for Model 3300
1	85 to 265 VAC
2	18 to 30 VDC (recommended for 24 VDC users)

Communication

Code	Product description
A	No communication gateway module

Hardware

Code	Additional hardware modules for Model 3300
0	No additional hardware modules
1	Weights & Measures Custody Transfer (all other than OIML); Control Application code must be code D (Discrete Batch Controller)

Sensor

Code	Sensor interface for Model 3300
0	No sensor interface

Terminals

Code	Terminal options for Model 3300
B	Wiring terminals
C	Prepared cables; 2 ft (1 m) length; use with mounting code P only
D	Prepared cables; 5 ft (2 m) length; use with mounting code P only
E	Prepared cables; 10 ft (3 m) length; use with mounting code P only

Relays and housings

Code	Relays and housing options for Model 3300
1	No relays and housing

Approvals

Code	Approval options for Model 3300
M	Micro Motion Standard (no approval, with CE/EAC mark)
U	UL
C	CSA (Canada only)
A	CSA C-US (U.S.A. and Canada)

Language

Code	Language options for Model 3300
A	English local display; Danish quick reference guide; English manual
D	English local display; Dutch quick reference guide; English manual
E	English local display; English quick reference guide; English manual
F	French local display; French quick reference guide; French manual

Code	Language options for Model 3300
G	German local display; German quick reference guide; German manual
H	English local display; Finnish quick reference guide; English manual
I	English local display; Italian quick reference guide; English manual
J	Japanese local display; Japanese quick reference guide; English manual
M	English local display; Chinese quick reference guide; Chinese manual
N	English local display; Norwegian quick reference guide; English manual
O	English local display; Polish quick reference guide; English manual
P	English local display; Portuguese quick reference guide; English manual
S	English local display; Spanish quick reference guide; Spanish manual
W	English local display; Swedish quick reference guide; English manual
C	English local display; Czech CE requirements document, English manual and quick reference guide
B	English local display; Hungarian CE requirements document, English manual and quick reference guide
K	English local display; Slovak CE requirements document, English manual and quick reference guide
T	English local display; Estonian CE requirements document, English manual and quick reference guide
U	English local display; Greek CE requirements document, English manual and quick reference guide
L	English local display; Latvian CE requirements document, English manual and quick reference guide
V	English local display; Lithuanian CE requirements document, English manual and quick reference guide
Y	English local display; Slovenian CE requirements document, English manual and quick reference guide

Control software

Code	Control application software for Model 3300
Z	Process monitor/totalizer (standard)
D	Discrete batch controller

Measurement software

Code	Measurement application software for Model 3300
Z	No measurement application software

Specialty applications

Code	Specialty applications for Model 3300
Z	No specialty applications
X	ETO application

Model 3350

Base model

Model	Product description
3350	Micro Motion Coriolis Discrete Controller; remote field-mount

Mounting

Code	Mounting options for Model 3350
A	Field-mount

Power

Code	Power options for Model 3350
1	85 to 265 VAC
2	18 to 30 VDC (recommended for 24 VDC users)

Communication

Code	Communication gateway module for Model 3350
A	No communication gateway module

Hardware

Code	Additional hardware modules for Model 3350
0	No additional hardware modules
1	Weights & Measures Custody Transfer (all other than OIML); Control Application code must be code D (Discrete Batch Controller)

Sensor

Code	Sensor interface for Model 3350
0	No sensor interface

Conduit connections

Code	Conduit connection options for Model 3350
A	M20 without glands
B	M20 with three increased safety glands
C	M20 with five increased safety glands
D	3/4-inch NPT without conduit seals

Approval

Code	Approval options for Model 3350
M	Micro Motion Standard (no approval, with CE/EAC mark)
U	UL
C	CSA (Canada only)
A	CSA (US and Canada)
I	IECEX EPL Gb, Ex de, Zone 1
Z	ATEX II 2G, Ex de, Zone 1
P	NEPSI – Safe area Only available with language code M (Chinese)

Language

Code	Language options for Model 3350
A	Danish CE requirements document; English installation and configuration manuals
D	Dutch CE requirements document; English installation and configuration manuals
E	English installation manual; English configuration manual
F	French installation manual; French configuration manual
G	German installation manual; German configuration manual
H	Finnish CE requirements document; English installation and configuration manuals
I	Italian installation manual; English configuration manual
J	Japanese installation manual; Japanese configuration manual
M	Chinese installation manual; Chinese configuration manual
N	Norwegian CE requirements document; English installation and configuration manuals
O	Polish installation manual; English configuration manual
P	Portuguese installation manual; English configuration manual
S	Spanish installation manual; Spanish configuration manual
W	Swedish CE requirements document; English installation and configuration manuals
C	Czech CE requirements: English installation and configuration manuals
B	Hungarian CE requirements document; English installation and configuration manuals
K	Slovak CE requirements document; English installation and configuration manuals
T	Estonian CE requirements document; English installation and configuration manuals
U	Greek CE requirements document; English installation and configuration manuals
L	Latvian CE requirements document; English installation and configuration manuals
V	Lithuanian CE requirements document; English installation and configuration manuals
Y	Slovenian CE requirements document; English installation and configuration manuals

Software 1

Code	Software options 1 for Model 3350
Z	Flow variable (standard)
J	Production volume reconciliation Available with software option 2 Z and C only
K	Transient mist remediation Available with software option 2 Z and C only
L	Transient bubble remediation Available with software option 2 Z and C only
R	Piece-wise linearization for gas Available with software option 2 Z and C only

Software 2

Code	Software options 2 for Model 3350
Z	No software options 2
C	Smart Meter Verification Not available with Mounting Option I, B, C, or P; Smart Meter Verification is not available with all sensors.
S	Safety certification of 4–20 mA output per IEC 61508 Only available with output code A or D
V	Safety Certification per IEC 61508 with Smart Meter Verification Not available with Mounting Option I, B, C, or P; Smart Meter Verification is not available with all sensors. Only available with output code A or D

Factory

Code	Factory options for Model 3350
Z	Standard product
X	ETO product

Add on Options

Code	Add on options for Model 3350
CL	Hardware for cover lockout Hardware only; does not include Weights & Measures software
PK	2 in (51 mm) pipe mount U-bolt kit for electronics Not available with Mounting Option I
	Country specific approval (select one from the following if approval code G is selected)
R1	EAC Zone 2 - Hazardous Area Approval - Increased safety terminal compartment (Exe)
R2	EAC Zone 1 - Hazardous Area Approval - Flameproof terminal compartment
B1	INMETRO Zone 1 - Hazardous Area Approval - Increased safety terminal compartment
B2	INMETRO Zone 1 - Hazardous Area Approval - Flameproof terminal compartment

Model 3500

Base model

Model	Product description
3500	Micro Motion 3500 controller transmitter remote rack/panel-mount

Mounting

Code	Mounting options for Model 3500
R	DIN rack
P	Panel-mount

Power

Code	Power options for Model 3500
1	85 to 265 VAC
2	18 to 30 VDC (recommended for 24 VDC users)

Remote core processor

Code	Remote core processor options for Model 3500
With sensor interface code 5	
A	None
With sensor interface code 6 (remote core processor)	
B	0.5 in (13 mm) -- NPT remote core processor -- no gland
E	M20 remote core processor -- no gland
F	Remote core processor -- brass/nickel cable gland Not available with Approval Code T or S
G	Remote core processor -- stainless steel cable gland Not available with Approval Code T or S
K	JIS B0202 1/2G -- no gland (not available for quotes outside of Japan) Only available with Approval Code M
L	Japan -- brass nickel cable gland (not available for quotes outside of Japan) Only available with Approval Code M
M	Japan -- stainless steel cable gland (not available for quotes outside of Japan) Only available with Approval Code M

Hardware

Code	Additional hardware modules for Model 3500
0	No additional hardware modules
1	Weights & Measures Custody Transfer (all other than OIML); Control Application code must be either code D or E (Discrete Batch Controller)

Code	Additional hardware modules for Model 3500
2	Weights & Measures Custody Transfer (OIML); MID 2004/22/EC compliant, based on OIML R117-1 and OIML R137-1; Evaluation Certificate TC7057
3	Marine Bunker Hardware; Must be used with CMF200, CMF300, CMF350, CMFHC, or F300 sensor; Not available with Approval Code U; Not available with Approval Code T or S

Sensor

Code	Sensor interface for Model 3500
5	4-wire MVD interface to sensors with core processors (includes 10 ft (3 m) 4-wire shielded PVC cable)
6	4-wire remote mount transmitter with 9-wire remote core processor to sensors with junction box; (includes 10 ft (3 m) each 9-wire shielded FEP and 4 wire shielded PVC cable)
7	4-wire remote mount transmitter with 9-wire remote enhanced core processor to sensors with junction box; (includes 10 ft (3 m) each 9-wire shielded FEP and 4 wire shield PVC cable); Not available with Approval Codes T or S; Only available with approvals M, C, A, B, or P

Terminals

Code	Terminal options for Model 3500
B	Screw terminals
C	Prepared cables; 2 ft (1 m) length (use with mounting code P only)
D	Prepared cables; 5 ft (2 m) length (use with mounting code P only)
E	Prepared cables; 10 ft (3 m) length (use with mounting code P only)

Relays and housings

Code	Power options for Model 3500
1	No relays and housing

Approval

Code	Approval options for Model 3500
M	Micro Motion Standard (no approval, with CE/EAC mark)
U	UL Approval Code U is available with Remote Core Conduit Connections B or E only
C	CSA (Canada only)
A	CSA (US and Canada)
B	ATEX II (2) G [Ex ib] IIB/IIC
P	NEPSI – Safe area Only available with language code M (Chinese)

Code	Approval options for Model 3500
G	Country Specific Approval -- Requires a selection from the Approvals section of the “Certificate, Tests, Calibrations and Services” model code options. Only available with language code M (Chinese)

Language

Code	Language options for Model 3500
A	English local display; Danish quick reference guide; English manual
D	English local display; Dutch quick reference guide; English manual
E	English local display; English quick reference guide; English manual
F	French local display; French quick reference guide; French manual
G	German local display; German quick reference guide; German manual
H	English local display; Finnish quick reference guide; English manual
I	English local display; Italian quick reference guide; English manual
J	Japanese local display; Japanese quick reference guide; English manual
M	English local display; Chinese quick reference guide; Chinese manual
N	English local display; Norwegian quick reference guide; English manual
O	English local display; Polish quick reference guide; English manual
P	English local display; Portuguese quick reference guide; English manual
S	English local display; Spanish quick reference guide; Spanish manual
W	English local display; Swedish quick reference guide; English manual
B	English local display; Hungarian CE requirements document; English manual and quick reference guide
C	English local display; Czech CE requirements document; English manual and quick reference guide
K	English local display; Slovak CE requirements document; English manual and quick reference guide
L	English local display; Latvian CE requirements document; English manual and quick reference guide
T	English local display; Estonian CE requirements document; English manual and quick reference guide
U	English local display; Greek CE requirements document; English manual and quick reference guide
V	English local display; Lithuanian CE requirements document; English manual and quick reference guide
Y	English local display; Slovenian CE requirements document; English manual and quick reference guide

Control software

Code	Control application software for Model 3500
Z	Process monitor/totalizer (standard)
C	Process monitor/totalizer; with Smart Meter Verification; Structural integrity method; Requires the transmitter to be connected to an enhanced core processor; Not available with Sensor Interface Code 6
D	Discrete batch controller

Code	Control application software for Model 3500
E	Discrete batch controller; with Smart Meter Verification; Structural integrity method; Requires the transmitter to be connected to an enhanced core processor; Not available with Sensor Interface Code 6
F	Marine Bunker Transfer Package; Available with Additional Hardware Code 3 only; Not available with Approval Code T or C
H	Marine Bunker Transfer Package and Smart Meter Verification; Structural integrity method; Available with Additional Hardware Code 3 only; Not available with Approval Code T or C

Measurement software

Code	Measurement application software for Model 3500
Z	No measurement application software
G	Concentration measurement Control application software must be Code Z, C, D, or E
B	Concentration measurement with predefined algorithms for food and beverage Control application software must be Code Z, C, D, or E
A	Petroleum measurement Control application software must be Code Z, C, D, or E
N	Net Oil Computer; Control software code must be C or Z

Specialty applications

Code	Specialty applications for Model 3500
Z	No specialty applications
X	ETO application

Add on options

Code	Add on options for Model 3500 ⁽¹⁾
R4	EAC safe area only
B4	INMETRO safe area only

(1) Country Specific Approvals (must select only one when Approvals code G is selected)

Model 3700

Base model

Model	Product description
3700	Micro Motion Coriolis multivariable transmitter and discrete controller; remote field-mount

Mounting

Code	Mounting options for Model 3700
A	Field mount

Power

Code	Power options for Model 3700
1	85 to 265 VAC
2	18 to 30 VDC (recommended for 24 VDC users)

Remote core processor

Code	Remote core processor options for Model 3700
With sensor interface code 5	
A	None
With sensor interface code 6 (remote core processor)	
B	0.5 in (13 mm) -- NPT remote core processor -- no gland
E	M20 remote core processor — no gland
F	Remote core processor — brass/nickel cable gland
G	Remote core processor — stainless steel cable gland
K	JIS B020G — no gland (not available for quotes outside of Japan)
L	Japan — brass nickel cable gland (not available for quotes outside of Japan)
M	Japan — stainless steel cable gland (not available for quotes outside of Japan)

Hardware

Code	Additional hardware modules for Model 3700
0	No additional hardware modules
1	Weights & Measures Custody Transfer (all other than OIML); Control Application code must be either code D or E (Discrete Batch Controller)
2	Weights & Measures Custody Transfer (OIML); MID 2004/22/EC compliant, based on OIML R117-1 and OIML R137-1; Evaluation Certificate TC7057; Not a available with Approval Code P
3	Marine Bunker hardware; Must be used with CMF200, CMF300, CMF350, CMF400, CMFHC< or F300 sensor; Not available with Approval Code U; Requires the use of a 4-wire interface to an enhanced core processor; Not available with sensor interface code 6

Sensor

Code	Sensor interface for Model 3700
5	4-wire interface to sensors with core processors (includes 10 ft (3 m) 4-wire shielded PVC cable)

Code	Sensor interface for Model 3700
6	4-wire remote mount transmitter with 9-wire remote core processor to sensors with junction box (includes 10 ft (3 m) each 9-wire shielded FEP and 4-wire shielded PVC cable)
7	4-wire remote mount transmitter with 9-wire remote enhanced core processor to sensors with junction box (includes 10 ft (3 m) each 9-wire shielded FEP and 4-wire shielded PVC cable); Only available with Approval Code G

Conduit connections

Code	Conduit connection options for Model 3700
A	M20 without glands
B	M20 with three brass nickel increased safety glands
C	M20 with five brass nickel increased safety glands
D	0.75 in (19.0 mm) NPT without conduit seals
S ⁽¹⁾	Japan - with three 1/2G brass nickel cable glands
T ⁽¹⁾	Japan - with five 1/2G brass nickel cable glands
U ⁽¹⁾	Japan - with three 1/2G stainless steel cable glands
V ⁽¹⁾	Japan - with five 1/2G stainless steel cable glands

(1) Only available with Approval code M. Not available for quotes outside of Japan.

Approval

Code	Approval options for Model 3700
M	Micro Motion standard (no approval)
U	UL Approval Code U is available with Remote Core Conduit Connections B or E and standard Conduit connection codes A or D only.
C	CSA (Canada only)
A	CSA (US and Canada)
I	IECEx EPL Gb, Ex de [ib], Zone 1 Flameproof
Z	ATEX II 2 G, Ex de [ib], Zone 1
G	Country Specific Approval Requires a selection from the Approvals section of the 'Certificate, Tests, Calibrations and Services' model option codes.
P	NEPSI – Safe area Only available with language code M (Chinese)

Language

Code	Language options for Model 3700
A	English local display; Danish quick reference guide; English manual
D	English local display; Dutch quick reference guide; English manual
E	English local display; English quick reference guide; English manual

Code	Language options for Model 3700
F	French local display; French quick reference guide; French manual
G	German local display; German quick reference guide; German manual
H	English local display; Finnish quick reference guide; English manual
I	English local display; Italian quick reference guide; English manual
J	Japanese local display; Japanese quick reference guide; English manual
M	English local display; Chinese quick reference guide; Chinese manual
N	English local display; Norwegian quick reference guide; English manual
O	English local display; Polish quick reference guide; English manual
P	English local display; Portuguese quick reference guide; English manual
S	English local display; Spanish quick reference guide; Spanish manual
W	English local display; Swedish quick reference guide; English manual
B	English local display; Hungarian CE requirements document; English manual and quick reference guide
C	English local display; Czech CE requirements document; English manual and quick reference guide
K	English local display; Slovak CE requirements document; English manual and quick reference guide
L	English local display; Latvian CE requirements document; English manual and quick reference guide
T	English local display; Estonian CE requirements document; English manual and quick reference guide
U	English local display; Greek CE requirements document; English manual and quick reference guide
V	English local display; Lithuanian CE requirements document; English manual and quick reference guide
Y	English local display; Slovenian CE requirements document; English manual and quick reference guide

Control software

Code	Control application software for Model 3700
Z	Process monitor/totalizer (standard)
C	Process monitor/totalizer; with Smart Meter Verification; Structural integrity method; Requires the transmitter to be connected to an enhanced core processor.
D	Discrete batch controller
E	Discrete batch controller; with Smart Meter Verification; Structural integrity method; Requires the transmitter to be connected to an enhanced core processor.
F	Marine Bunker Transfer Package; Available with Additional Hardware Code 3 only.
H	Marine Bunker Transfer Package and Smart Meter Verification; Structural integrity method; Available with Additional Hardware Code 3 only

Measurement software

Code	Measurement application software for Model 3700
Z	No measurement application software

Code	Measurement application software for Model 3700
G	Concentration measurement Control Application Software must be Code Z, C, D, or E
B	Concentration measurement with predefined algorithms for food and beverage Control Application Software must be Code Z, C, D, or E
A	Petroleum measurement Control Application Software must be Code Z, C, D, or E
N	Net Oil Computer; Control software code must be C or Z

Specialty applications

Code	Specialty applications for Model 3700
Z	No specialty applications
X	ETO application

Add on option

Code	Specialty applications for Model 3700
LR	Lloyd's BV and DNV Approval for Marine (includes necessary hardware) Must be used with CMF400 or CMFHC sensor
Country Specific Approvals (must select only one when approvals option G selected)	
R1	EAC Zone 1 -- Hazardous Area Approval Only available with Approval Code G
B1	INMETRO Zone 1 -- Hazardous Area Approval Only available with Approval Code G

Model 3100 high energy relay

Base model

Model	Product description
3100	Micro Motion multivariable transmitter and discrete controller; remote rack/panel-mount

Device (order separately)

Code	Mounting options for Model 3100
A	3 relays; 24–250 VAC; 5A
B	3 relays; 0–70 VDC; 5A

Housing

Code	Power options for Model 3100
1	No housing
2	NEMA 4X housing for relays only

Future expansion

Code	Future expansion options for Model 3100
A	Reserved for future use

Approval

Code	Approval options for Model 3100
M	Micro Motion standard (no approval)
U	UL Class 1, Div. 2, Groups A, B, C, and D
C	CSA Class 1, Div. 2, Groups A, B, C, and D