



**thermoMETER CTratioM1**

Glass fiber 2 colour ratio thermometer for extreme temperature measurements. The ratiometric principle minimises measurement errors caused by intensity change (e.g. contamination due to dust, fumes..), low emissivity and partial spot size coverage of the target.

- Temperature range from 700°C to 1800°C
- 5ms response time for fast readings
- Short wave length 0.7 and 1.1µm
- Rugged sensor head withstands 250°C without cooling
- High optical resolution with variable focus optics
- Laser target marker down to 1.3 mm spot size
- Programmable 1 or 2 colour mode
- Separate controller with easy accessible programming keys and multi colour LCD backlit display

**Optical specification thermoMETER CTratioM1**

□ = smallest spot size (mm)

Standard optics										
<b>SF40 optics</b>	40:1	6.6	10.6	21.1	31.3	41.4	52	62.6	73.3	84
	distance in mm	102	305	762	1143	1524	1905	2286	2667	3048
Close Focus optics										
<b>CF02 optics</b>	2:1	5.1	6.4	7.7	23.6	50.1	77.6	104.1		
	distance in mm	102	200	305	762	1524	2286	3048		

## Product identification

CTratioM - 1 CF02 - C2

Fiber cable length [3 m (standard) / 6 / 10 / 15 / 22 m]  
 Focus [CF02/SF40]  
 Spectral range  
 thermoMETER CTratio

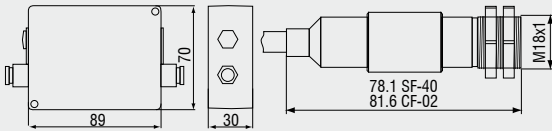

Model	CTratioM-1CF02-C2	CTratioM-1SF40-C2
Optical resolution (95% Energy)	40:1	
Temperature range	700°C to 1800°C	
Spectral range	0.7 and 1.1µm	
System accuracy <sup>1,3</sup>	±(0.5% of reading + 1°C)	
Repeatability <sup>1,3</sup>	±(0.2% of reading + 1°C)	
Temperature resolution (>900°C)	0.1°C	
Response time (95% signal) <sup>2</sup>	5ms - 10s	
Slope <sup>4</sup>	0.800 to 1.200	
Emissivity <sup>4</sup>	0.100 to 1.100	
Signal processing <sup>4</sup>	1 colour / 2 colour mode; attenuation monitoring / alarms; peak hold, valley hold, average; extended hold function with threshold and hysteresis	
Outputs/analogue	0/4 - 20 mA, 0 to 5/10 V	
Outputs/analogue	optional	relay: 2 x 60VDC/ 42VAC <sub>eff</sub> ; 0.4A; optically isolated
Alarm output	2 x open - collector (24 V/1 A)	
Outputs/digital	optional	USB, RS232, RS485, CAN, Profibus DP, Ethernet
Output impedances	current output	mA max. 500 Ω (with 5 - 36 VDC)
	voltage output	mV min. 100 kΩ load impedance
Inputs/outputs digital	2 programmable in-/ outputs, usable as: Alarm output (open collector output [24 V/ 1 A]) Digital input for triggered signal output and peak hold function	
Fiber cable length	3m (standard), 6m, 10m, 15m , 22m; stainless steel armour, 400µm fiber diameter	
Power supply	8 to 36VDC or USB; max. 200mA	
Optical aiming	Laser 650nm, 1mW, ON/OFF via controller or software	
Environmental rating	IP 65 (NEMA-4)	
Operation temperature	sensor: -20°C to 250°C (70°C if Laser ON); controller: 0°C to 85°C	
Storage temperature	sensor: -40°C to 250°C ; controller: -40°C to 85°C	
Relative humidity	10 to 95%, non condensing	
Vibration	sensor	IEC 68-2-6: 3 G, 11-200Hz, any axis
Shock	sensor	IEC 68-2-27: 50 G, 11ms, any axis
Weight	fiber cable with sensor: 375g; controller: 420g	

<sup>1</sup> E = 1, response time 1s<sup>2</sup> with dynamic adaptation at low signal levels<sup>3</sup> ± at ambient temperature 23 ± 5°C<sup>4</sup> adjustable via programming keys or software

**LASER RADIATION**  
 DO NOT STARE IN THE BEAM  
 CLASS 2 LASER  
 EN60825-1:2002  
 P ≤ 1mW; λ = 650nm

**Controller**

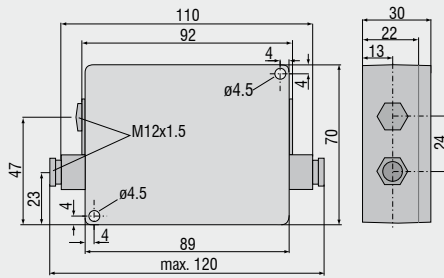

**CTLaser / CTLaserFAST / CTLaserGLASS / CTLaserM1/M2 / CTLaserM3 / CTLaserCOMBUSTION**

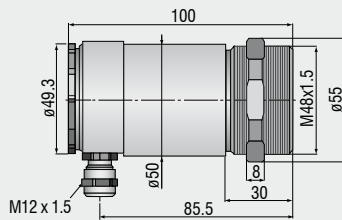

**CTratioM1**

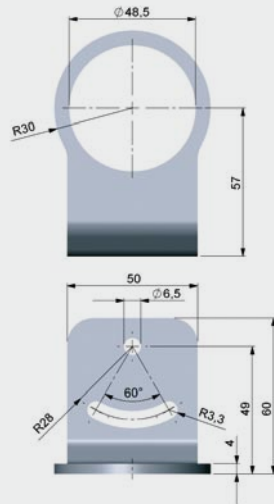
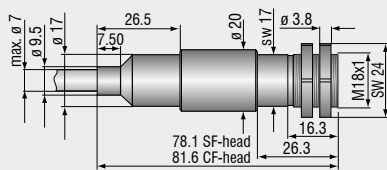

TM-FB-CTL Mounting bracket (fixed); included with CTL sensors

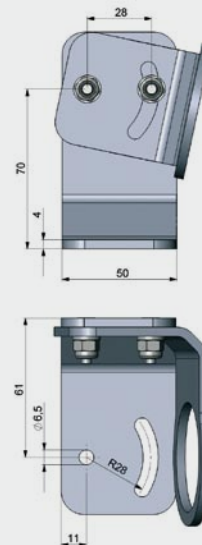

TM-AB-CTL Mounting bracket (adjustable)



TM-W-CTL Water cooled housing and air purge collar TM-AP-CTL, mounted on adjustable mounting bracket TM-AB-CTL

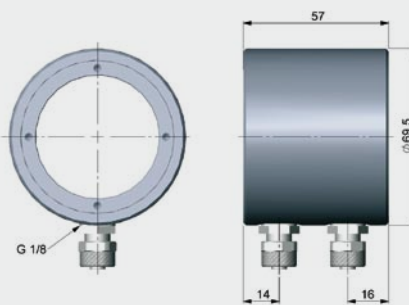

TM-W-CTL Water cooled housing

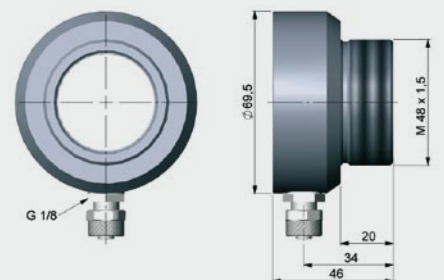

TM-AP-CTL Air purge collar

**Mechanical accessories**

Art. No.	Model	
2970238	TM-AB-CTL	Mounting bracket, adjustable, stainless steel
2970239	TM-AP-CTL	Air purge collar, stainless steel
2970240	TM-W-CTL	Water cooled housing, stainless steel, for ambient temperatures up to 175°C
2970241	TM-RAIL-CTL	Rail mount adapter for CTlaser controller
2970242	TM-COV-CTL	Closed cover for controller
2970243	TM-MN-CTL	Mounting nut, stainless steel (spare)
2970244	TM-FB-CTL	Mounting bracket, fixed, stainless steel (spare)
2970298	TM-A20UN-CTL	Screw adapter M48x1 on 20UN-2A screw including mounting nut

**High temperature accessories**

2970366	TM-J-CTL	Cooling jacket (length 228mm, ø89mm) (connection kit TM-CONK-CTL is required)
2970374	TM-CONK-CTL	Connection kit: sensor with axial cable exit, for integration in cooling jacket
2970368	TM-JAB-CTL	Adjustable mounting bracket for cooling jacket
2970369	TM-MF-CTL	Mounting flange M48x1.5 for mounting a CTL sensor
2970370	TM-AST300-CTL	Sighting tube M48x1.5, 300 mm length
2970371	TM-PA-CTL	Pipe adapter M48x1.5
2970372	TM-RM-CTL	Furnace wall mount accessory for CTlaser (TM-MF-CTL, TM-AST300-CTL and TM-PA-CTL)

**Calibration**

2970253	TM-CERT-CTL	Certificate of calibration
2970324	TM-HTCERT-CTL	Certificate of calibration for CTlaser M1-/M2-/M3-/G-

**Interfaces**

2970245	TM-USBK-CTL	USB interface kit incl. computer cable, software CompactConnect
2970246	TM-RS232K-CTL	RS232 interface kit incl. computer cable, software CompactConnect
2970338	TM-RS485USBK-CTL	RS485-USB-adapter, incl. PC cable, RS485 board, software CTconnect, terminal block, for use with TM-485B-CTL
2970248	TM-RS485B-CTL	RS485 interface board
2970249	TM-CANK-CTL	CAN-Bus interface for optris CT/ protocol: CANopen Presettings: module address 20 (14H), 250kBaud, 0-60°C
2970250	TM-PFBDPK-CTL	Profibus-DPv1 interface for CT selectable with DIN M12 or SUB-D connection
2970251	TM-ETHNK-CTL	Ethernet-Kit: interface board, external Ethernet adapter, software CompactConnect
2970252	TM-RI-CTL	Relay interface: Two optically isolated relays, 60VDC/ 42VACRMS, 0.4A

**Sensor cables and high temperature cables**

2970374	TM-CONK-CTL	Connector-Kit for cables with connector
4800254.003	TM-CB3C-CTL	Sensor cable with adapter (3m)
4800254.003H	TM-CB3HC-CTL	High-temperature sensor cable with adapter (3m)
4800254.008	TM-CB8C-CTL	Sensor cable with adapter (8m)
4800254.008H	TM-CB8HC-CTL	High-temperature sensor cable with adapter (8m)
4800254.015	TM-CB15C-CTL	Sensor cable with adapter (15m)
4800254.015H	TM-CB15HC-CTL	High-temperature sensor cable with adapter (15m)



TM-J-CTL Cooling jacket (length 228mm, ø89mm) with adjustable mounting bracket TM-JAB-CTL; up to 315°C ambient temperature



TM-MF-CTL Mounting flange M48x1.5 for mounting a CTL sensor



TM-RM-CTL Furnace wall mount accessory for CTlaser / CTratio: TM-MF-CTL, TM-AST300-CTL und TM-PA-CTL

**CTratio**

Art. No.	Model	
2970348	TM-FB-CTR	Mounting bracket, adjustable in one axis
2970349	TM-AB-CTR	Mounting bracket, adjustable in two axes
2970395	TM-AP-CTR	Air purge collar
2970373	TM-RM-CTR	Furnace wall mount accessory for CTratio